

A Course Material on

EE8602 – PROTECTION AND SWITCHGEAR

By

Mr.K.ANAND

ASSISTANT PROFESSOR

DEPARTMENT OF ELECTRICAL AND ELECTRONICS ENGINEERING

PRATHYUSHA ENGINEERING COLLEGE

UNIT I INTRODUCTION 9

Importance of protective schemes for electrical apparatus and power system. Qualitative review of faults and fault currents - relay terminology – definitions - and essential qualities of protection. Protection against over voltages due to lightning and switching - arcing grounds - Peterson Coil - ground wires - surge absorber and diverters Power System earthing – neutral Earthing - basic ideas of insulation coordination.

UNIT II OPERATING PRINCIPLES AND RELAY CHARACTERISTICS 9

Electromagnetic relays – over current, directional and non-directional, distance, negative sequence, differential and under frequency relays – Introduction to static relays.

UNIT III APPARATUS PROTECTION 9

Main considerations in apparatus protection - transformer, generator and motor protection - protection of busbars. Transmission line protection - zones of protection. CTs and PTs and their applications in protection schemes.

UNIT IV THEORY OF CIRCUIT INTERRUPTION 9

Physics of arc phenomena and arc interruption. DC and AC circuit breaking - restriking voltage and recovery voltage - rate of rise of recovery voltage - resistance switching - current chopping - interruption of capacitive current.

UNIT V CIRCUIT BREAKERS 9

Types of circuit breakers – air blast, air break, oil, SF₆ and vacuum circuit breakers – comparative merits of different circuit breakers – testing of circuit breakers.

TOTAL : 45 PERIODS

TEXT BOOKS:

1. M.L. Soni, P.V. Gupta, V.S. Bhatnagar, A. Chakrabarti, 'A Text Book on Power System Engineering', Dhanpat Rai & Co., 1998. (For All Chapters 1, 2, 3, 4 and 5).
2. R.K.Rajput, A Text book of Power System Engineering. Laxmi Publications, First Edition Reprint 2007.

REFERENCES:

1. Sunil S. Rao, 'Switchgear and Protection', Khanna publishers, New Delhi, 1986.
2. C.L. Wadhwa, 'Electrical Power Systems', Newage International (P) Ltd., 2000.
3. B. Ravindranath, and N. Chander, 'Power System Protection & Switchgear', Wiley Eastern Ltd., 1977.
4. Badri Ram, Vishwakarma, 'Power System Protection and Switchgear', Tata McGraw Hill, 2001.

CONTENTS

S.NO	TOPIC	PAGE NO.
UNIT I INTRODUCTION		1
1.1	Fundamentals of Power System Protection	1
1.2	Consequences of occurrence of Faults	2
1.3	Zones and types of Protection system	3
1.4	Protection System Requirements and some basic terminologies used	4
1.5	Protection against over voltages due to lightning and switching	6
1.6	Arcing Grounds	9
1.7	surge absorber	9
1.8	surge diverter	11
1.9	neutral earthing	13
UNIT II OPERATING PRINCIPLES AND RELAY CHARACTERISTICS		29
2.1	Electromagnetic Relay	22
2.2	Over Current Relay Working Principle Types	26
2.3	Directional Over Current Relays	28
2.4	Distance relay	28
2.5	Impedance Relay	29
2.6	Differential Relay	30
2.7	Static relays	33
UNIT III APPARATUS PROTECTION		34
3.1	Over current and earth fault protection	34
3.2	Transformer Protection	39
3.3	Generator protection	46
3.4	Protection of bus bars	50
3.5	Zones and types of Protection system	52
3.6	CTs and PTs and their applications in protection schemes	53
UNIT IV THEORY OF CIRCUIT INTERRUPTION		56
4.1	Formation of arc during circuit breaking	56
4.2	AC and DC circuit breaking	59
4.3	Restriking voltage and recovery voltage	60
4.4	Rate of rise of recovery voltage	61
4.5	Resistance switching	62
4.6	Current chopping	64
UNIT V CIRCUIT BREAKERS		67
5.1	Rating of Circuit Breaker	67
5.2	Air blast circuit breaker	70

5.3	Oil circuit breakers	73
5.4	SF6 circuit breaker	76
5.5	Vacuum circuit breakers	78
5.6	Testing of circuit breakers	80
	Question bank	82

UNIT I

INTRODUCTION

1. Importance of protective schemes for electrical apparatus and power

system 1.1 Fundamentals of Power System Protection

The purpose of an Electric Power System is to generate and supply electrical energy to consumers. The power system should be designed and managed to deliver this energy to the utilization points with both reliability and economically. The capital investment involved in power system for the generation, transmission and distribution is so great that the proper precautions must be taken to ensure that the equipment not only operates as nearly as possible to peak efficiency, but also must be protected from accidents. The normal path of the electric current is from the power source through copper (or aluminium) conductors in generators, transformers and transmission lines to the load and it is confined to this path by insulation. The insulation, however, may break down, either by the effect of temperature and age or by a physical accident, so that the current then follows an abnormal path generally known as Short Circuit or Fault.

- Any abnormal operating state of a power system is known as FAULT. Faults in general consist of short circuits as well as open circuits. Open circuit faults are less frequent than short circuit faults, and often they are transformed into short circuits by subsequent events.

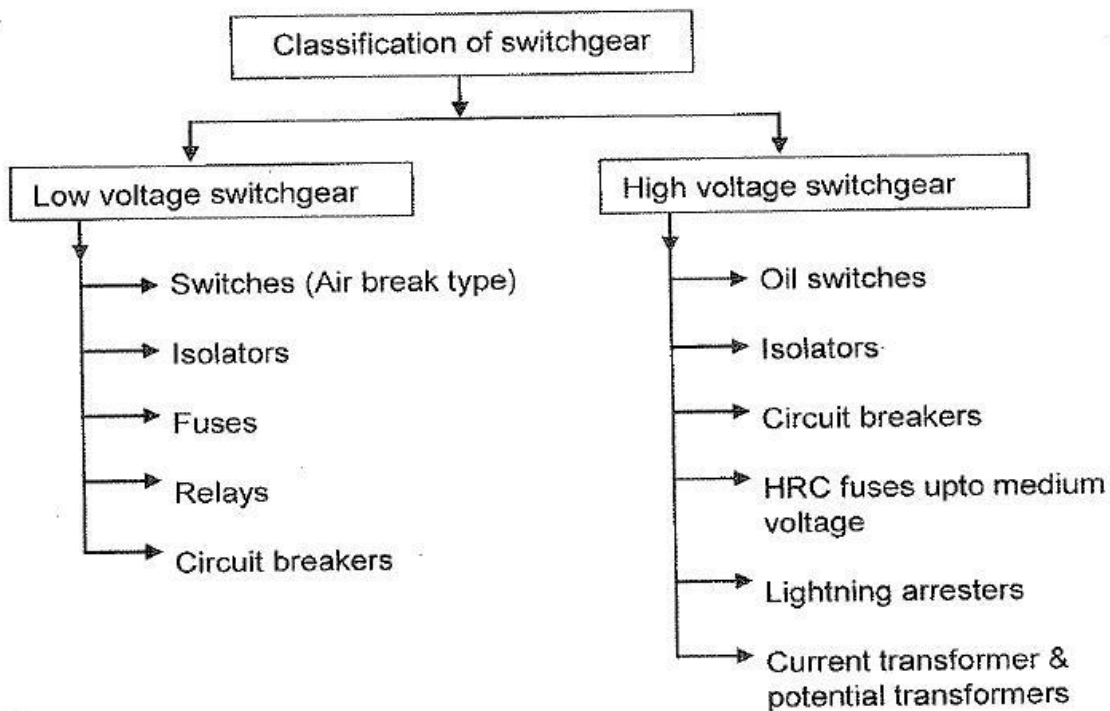

1.2 Consequences of occurrence of Faults

Faults are of two type

- Short circuit fault- current
- Open circuit fault- voltage

In terms of seriousness of consequences of a fault , short circuits are of far greater concern than open circuits, although some open circuits present some potential hazards to personnel

Classification of short circuited Faults

- Three phase faults (with or without earth connection)
- Two phase faults (with or without earth connection)
- Single phase to earth faults

Classification of Open Circuit Faults

- Single Phase open Circuit
- Two phase open circuit
- Three phase open circuit

Consequences

- Damage to the equipment due to abnormally large and unbalanced currents and low voltages produced by the short circuits
 - Explosions may occur in the equipments which have insulating oil, particularly during short circuits. This may result in fire and hazardous conditions to personnel and equipments
 - Individual generators with reduced voltage in a power station or a group of generators operating at low voltage may lead to loss of synchronism, subsequently resulting in islanding.
 - Risk of synchronous motors in large industrial premises falling out of step and tripping out.
- The general layout of a protection system may be viewed as given in the following figure

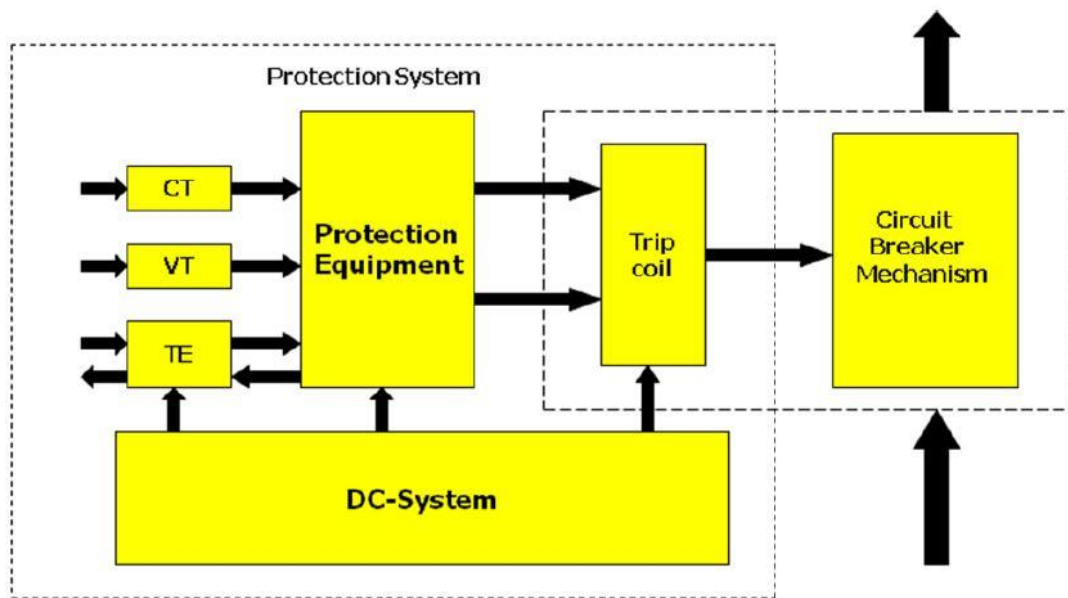

1.3 Zones and types of Protection system

Zones of Protection system

- An electric power system is divided into several zones of protection. Each zone of protection, contains one or more components of a power system in addition to two circuit breakers.
- When a fault occurs within the boundary of a particular zone, then the protection system responsible for the protection of the zone acts to isolate (by tripping the Circuit Breakers) every equipment within that zone from the rest of the system.
- The circuit Breakers are inserted between the component of the zone and the rest of the power system. Thus, the location of the circuit breaker helps to define the boundaries of the zones of protection.
- Different neighbouring zones of protection are made to overlap each other, which ensure that no part of the power system remains without protection. However, occurrence of the fault with in the overlapped region will initiate a tripping sequence of different circuit breakers so that the minimum necessary to disconnect the faulty element

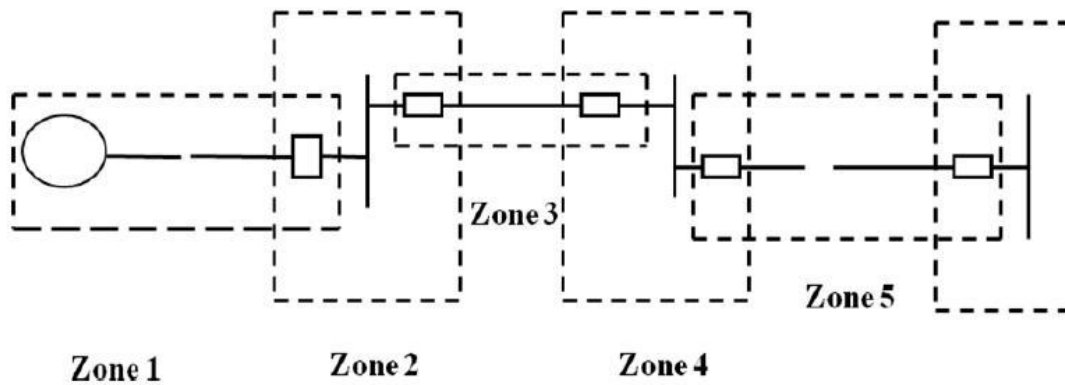

Types of Protection (Primary and Back-up Protection)

Primary Protection

The primary protection scheme ensures fast and selective clearing of any fault within the boundaries of the circuit element, that the zone is required to protect. Primary Protection as a rule is provided for each section of an electrical installation.

However, the primary protection may fail. The primary cause of failure of the Primary Protection system are enumerated below.

1. Current or voltage supply to the relay.
2. D.C. tripping voltage supply
3. Protective relays
4. Tripping circuit
5. Circuit Breaker

Back-up Protection

Back-up protection is the name given to a protection which backs the primary protection whenever the later fails in operation. The back-up protection by definition is slower than the primary protection system. The design of the back-up protection needs to be coordinated with the design of the primary protection and essentially it is the second line of defence after the primary protection system.

1.4 Protection System Requirements and some basic terminologies used

- The fundamental requirements for a protection system are as follows:

Reliability:

It is the ability of the protection system to operate correctly. The reliability feature has two basic elements, which are *dependability* and *security*. The dependability feature demands the certainty of a correct operation of the designed system, on occurrence of any fault. Similarly, the security feature can be defined as the ability of the designed system to avoid incorrect operation during faults. A comprehensive statistical

method based reliability study is required before the protection system may be commissioned. The factors which affect this feature of any protection system depends on some of the following few factors.

- Quality of Component used
- Maintenance schedule
- The supply and availability of spare parts and stocks
- The design principle
- Electrical and mechanical stress to which the protected part of the system is subjected to.

Speed:

Minimum operating time to clear a fault in order to avoid damage to equipment. The speed of the protection system consists primarily of two time intervals of interest.

The Relay Time :

This is the time between the instant of occurrence of the fault to the instant at which the relay contacts open.

The Breaker Time:

This is the time between the instant of closing of relay contacts to the instant of final arc extinction inside the medium and removal of the fault.

Selectivity:

This feature aims at maintaining the continuity of supply system by disconnecting the minimum section of the network necessary to isolate the fault. The property of selective tripping is also known as “discrimination”. This is the reason for which the entire system is divided into several protective zones so that minimum portion of network is isolated with accuracy. Two examples of utilization of this feature in a relaying scheme are as follows

- a) Time graded systems
- b) Unit systems

Sensitivity:

The sensitivity of a relay refers to the smallest value of the actuating quantity at which the relay operates detecting any abnormal condition. In case of an over current relay, mathematically this can be defined as the ratio between the short circuit fault current (I_s) and the relay operating current (I_o). The value of I_o , should not be too small or large so that the relay is either too sensitive or slow in responding.

Stability:

It is the quality of any protection system to remain stable within a set of defined operating narios and procedures. For example the biased differential scheme of differential protection is more stable towards switching transients compared to the more simple and basic Merz Price scheme in differential protection

Adequacy:

It is economically unviable to have a 100% protection of the entire system in concern. Therefore, the cost of the designed protection system varies with the criticality and importance of the protected zone. The protection system for more critical portions

is generally costly, as all the features of a good protection system is maximized here. But a small motor can be protected by a simple thermally operated relay, which is simple and cheap. Therefore, the cost of the protection system should be adequate in its cost. *1.4.7 Some basic terminologies used in protection system* Some basic terminologies commonly used in the protection system are enlisted below. i) Measuring Relay ii) Fault Clearing Time iii) Auxilliary relay iv) Relay Time v) Pick up value vi) Reset Value vii) Drop out viii) Reach (under and over reaches) ix) Relay Burden x) Unit/ Non unit protection xi) All or Nothing relay

1.5 Protection against over voltages due to lightning and switching**Overvoltage Protection****Under Electrical Protection**

There are always a chance of suffering an electrical power system from abnormal over voltages. These abnormal over voltages may be caused due to various reason such as, sudden interruption of heavy load, lightening impulses, switching impulses etc. These over voltage stresses may damage insulation of various equipments and insulators of the power system. Although, all the over voltage stresses are not strong enough to damage insulation of system, but still these over voltages also to be avoided to ensure the smooth operation of electrical power system.

Voltage Surge

The over voltage stresses applied upon the power system, are generally transient in nature. Transient voltage or voltage surge is defined as sudden rising of voltage to a high peak in very short duration. The voltage surges are transient in nature, that means they exist for very short duration. The main cause of these voltage surges in power system are due to lightning impulses and switching impulses of the system. But over voltage in the power system may also be caused by, insulation failure, arcing ground and resonance etc.

The voltage surges appear in the electrical power system due to switching surge, insulation failure, arcing ground and resonance are not very large in magnitude. These over voltages hardly cross the twice of the normal voltage level. Generally, proper insulation to the different equipment of power system is sufficient to prevent any damage due to these over voltages. But over voltages occur in the power system due to lightning is very high. If over voltage protection is not provided to the power system, there may be high chance of severe damage. Hence all over voltage protection devices used in power system mainly due to lightning surges. Let us discuss different causes of over voltages one by one.

Switching Impulse or Switching Surge

When a no load transmission line is suddenly switched on, the voltage on the line becomes twice of normal system voltage. This voltage is transient in nature. When a loaded line is suddenly switched off or interrupted, voltage across the line also becomes high enough current chopping in the system mainly during opening operation of air blast circuit breaker, causes over voltage in the system. During insulation failure, a live conductor is suddenly earthed. This may also caused sudden over voltage in the system. If emf wave produced by alternator is distorted, the trouble of resonance may occur due to 5th or higher harmonics. Actually for frequencies of 5th or higher harmonics, a critical situation in the system so appears, that inductive reactance of the system becomes just equal to capacitive reactance of the system. As these both reactance cancel each other the system becomes purely resistive. This phenomenon is called resonance and at resonance the system voltage may be increased enough.

But all these above mentioned reasons create over voltages in the system which are not very high in magnitude.

But over voltage surges appear in the system due to lightning impulses are very high in amplitude and highly destructive. The affect of lightning impulse hence must be avoided for over voltage protection of power system.

Methods of Protection Against Lightning

These are mainly three main methods generally used for protection against lightning. They are

1. **Earthing screen.**
2. **Overhead earth wire.**

3. **Lightning arrester or surge dividers.**

Earthing Screen

Earthing screen is generally used over electrical sub-station. In this arrangement a net of GI wire is mounted over the sub-station. The GI wires, used for earthing screen are properly grounded through different sub-station structures. This network of grounded GI wire over electrical sub-station, provides very low resistance path to the ground for lightning strokes.

This method of high voltage protection is very simple and economic but the main drawback is, it can not protect the system from travelling wave which may reach to the sub-station via different feeders.

Overhead Earth Wire

This method of over voltage protection is similar as earthing screen. The only difference is, an earthing screen is placed over an electrical sub-station, whereas, overhead earthwire is placed over electrical transmission network. One or two stranded GI wires of suitable cross-section are placed over the transmission conductors. These GI wires are properly grounded at each transmission tower. These overhead ground wires or earthwire divert all the lightning strokes to the ground instead of allowing them to strike directly on the transmission conductors.

Lightning Arrester

The previously discussed two methods, i.e. earthing screen and over-head earth wire are very suitable for protecting an electrical power system from directed lightning strokes but system from directed lightning strokes but these methods can not provide any protection against high voltage travelling wave which may propagate through the line to the equipment of the sub-station.

The lightning arrester is a devices which provides very low impedance path to the ground for high voltage travelling waves.

The concept of a lightning arrester is very simple. This device behaves like a nonlinear electrical resistance. The resistance decreases as voltage increases and vice-versa, after a certain level of voltage.

The functions of a lightning arrester or surge dividers can be listed as below.

1. Under normal voltage level, these devices withstand easily the system voltage as electrical insulator and provide no conducting path to the system current.
2. On occurrence of voltage surge in the system, these devices provide very low impedance path for the excess charge of the surge to the ground.
3. After conducting the charges of surge, to the ground, the voltage becomes to its normal level. Then lightning arrester regains its insulation properly and prevents regains its insulation property and prevents further conduction of current, to the ground.

There are different types of lightning arresters used in power system, such as rod gap arrester, horn gap arrester, multi-gap arrester, expulsion type LA, valve type LA.

In addition to these the most commonly used lightning arrester for over voltage protection now-a-days gapless ZnO lightning arrester is also used.

1.6 Arcing Grounds

Arcing Grounds is a phenomenon which is observed in ungrounded three phase systems. In ungrounded three phase systems operating in a healthy balanced conditions, capacitances are formed between the conductors and ground. The voltage across these capacitances is the phase voltage.

Now, in the event of a ground fault, the voltage across the faulty conductor becomes zero while the voltages across the healthy conductors increase by a factor of 1.732.

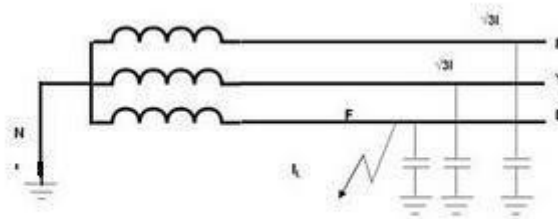

The arc caused between the faulty conductor and the ground gets extinguished and restarts many times, this repeated initiation and extinction of the arc across the fault produces severe voltage oscillations of the order of nearly three to four times the nominal voltage.

This repeated arcing across the fault due to the capacitances between the conductors and the ground is known as arcing grounds. Arcing grounds can be eliminated by the use of Peterson Coils (see Article) and Arc Suppression Coils

1.7 surge absorber

Surge absorbers are protective devices used to absorb the complete surge i.e. due to lightning surge or any transient surge in the system unlike the lightning arrester in which a non-linear resistor is provided which provides a low resistance path to the dangerously high voltages on the system to the earth.

Ferranti surge absorber Surge absorber is of following types:

Ferranti surge absorber: Ferranti surge absorber consists of an air core inductor which is connected in series with the line and surrounded by an earth metallic sheet. The earth metallic

sheet is known as dissipater, The dissipater is insulated from the inductor by the air as shown in Figure. This surge absorber acts like an air-cored transformer whose primary is the low inductance inductor and the dissipater as the single-turn short circuit secondary. Whenever a travelling wave is incident on the surge absorber, energy is transformed by mutual inductance between the coil and dissipater. Because of the series inductance the steepness of the wave is also reduced.

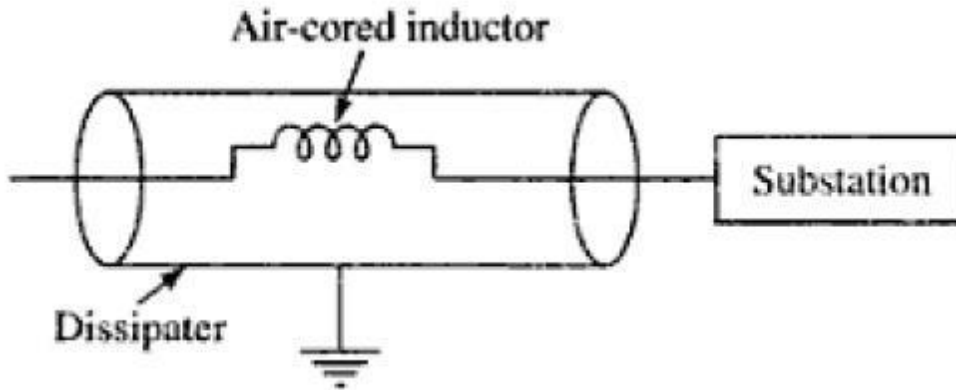

ERA surge absorber:

An improved form of the surge absorber is the Electrical Research Association (ERA)-type surge Filter as shown in Figure incorporated a gap G and expulsion gap E . When a wave reaches the inductor L , a high voltage is induced across it causing the gap G to break down putting the resistor R and expulsion gap E into circuit. An incoming wave is thus flattened by the inductor and the resistor and its amplitude is reduced by the expulsion gap.

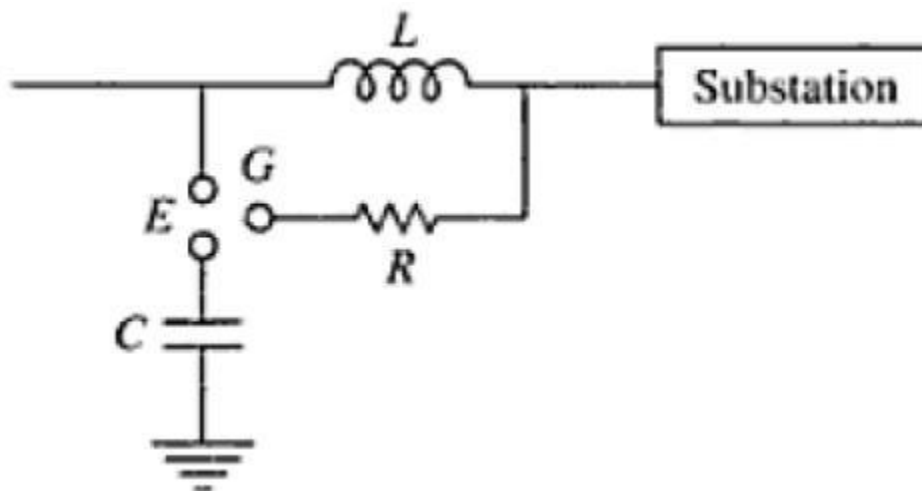

1.8 surge diverter

A **surge arrester** is a device to protect electrical equipment from over-voltage transients caused by external (lightning) or internal (switching) events. Also called a **surge protection device** (SPD) or **transient voltage surge suppressor** (TVSS), this class of device is used to protect equipment in power transmission and distribution systems. (For consumer equipment protection, different products called surge protectors are used.)

To protect a unit of equipment from transients occurring on an attached conductor, a surge arrester is connected to the conductor just before it enters the equipment. The surge arrester is also connected to ground and functions by routing energy from an over-voltage transient to ground if one occurs, while isolating the conductor from ground at normal operating voltages. This is usually achieved through use of a varistor, which has substantially different resistances at different voltages.

Surge arresters are not generally designed to protect against a direct lightning strike to a conductor, but rather against electrical transients resulting from lightning strikes occurring in the vicinity of the conductor. Lightning which strikes the earth results in ground currents which can pass over buried conductors and induce a transient that propagates outward towards the ends of the conductor. The same kind of induction happens in overhead and above ground conductors which experience the passing energy of an atmospheric EMP caused by the lightning flash. Surge arresters only protect against induced transients characteristic of a lightning discharge's rapid rise-time and will not protect against electrification caused by a direct strike to the conductor. Transients similar to lightning-induced, such as from a high voltage system's fault switching, may also be safely diverted to ground; however, continuous overcurrents are not protected against by these devices. The energy in a handled transient is substantially less than that of a lightning discharge; however it is still of sufficient quantity to cause equipment damage and often requires protection.

Without very thick insulation, which is generally cost prohibitive, most conductors running more than a minimal distance, say greater than about 50 feet, will experience lightning-induced transients at some time during use. Because the transient is usually initiated at some point between the two ends of the conductor, most applications install a surge arrester just before the conductor lands in each piece of equipment to be protected. Each conductor must be protected, as each will have its own transient induced, and each SPD must provide a pathway to earth to safely divert the transient away from the protected component. The one notable exception where they are not installed at both ends is in high voltage distribution systems. In general, the induced voltage is not sufficient to do damage at the electric generation end of the lines; however, installation at the service entrance to a building is key to protecting downstream products that are not as robust.

Surge Diverters operation

The event we commonly call a surge is more accurately defined as a high voltage transient or impulse. Surge diverters are designed to divert the impulse away from the sensitive electronic system. That's why the term diverter is more appropriate – it better describes the function of this device. Surge diverter products commonly use one or more of several electronic components. These include metal oxide varistors (MOVs), silicon avalanche diodes (SADs), and gas tubes. There are differences in how each functions but the intent is the same divert a part of the harmful impulse energy away from the computer or system being protected.

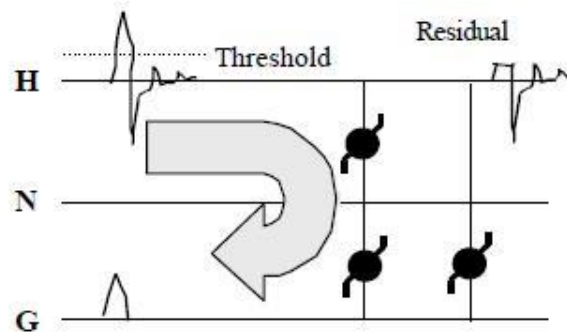

All surge diverters have a voltage threshold, called a “clamping voltage”, at which they began to conduct. Above that threshold, impulses are shunted across the diverter to another pathway. When the impulse voltage once again falls below the threshold, the diverter stops conducting. Surge diverters also have a “clamping response” time or the time required for the device to respond to an impulse. The amount of energy each is capable of handling without being destroyed is also a consideration. Due to these factors, each type of component used in surge diverters has unique advantages and disadvantages. MOVs have a high clamping voltage (300 to 500 volts) and a slow response time.

This means that in best case narios, voltage impulses of less than 500 volts usually enter the computer system unimpeded. In addition, higher voltage events with very fast rise times may pass by the MOV before it is able to respond. And while MOVs can handle a significant amount of energy, they are physically degraded each time they clamp. This characteristic alters their future performance and ultimately leads to physical failure.

These disadvantages have led to the use of the silicon avalanche diode (SAD) either in conjunction with the MOV or in standalone applications. Compared to MOVs, SADs have a faster response time and are not subject to the physical degradation that characterizes MOVs design. The overall energy handling ability of the SAD, however, is not as high, and an impulse that merely degrades and MOV may cause outright destruction of the SAD. To overcome this disadvantage, many surge diverter manufacturers whose designs use standalone SADs will parallel multiple SADs to increase the overall energy handling capability of the protector.

Industry authorities often vigorously debate the effectiveness of this design method. Gas tubes are comparatively slow and have a high clamp voltage. However, they handle almost unlimited amounts of energy. Some surge diverter designs have employed gas tubes as the final line of “brute force” protection to spare the lives of the other surge diverter components in the presence of a catastrophic powerline disturbance. In fact, many surge diverter designs incorporate paralleled MOVs, SADs, and/or gas tubes in an effort to improve performance by combining the relative strengths of each particular component

1.9 neutral earthing

Types of Neutral Earthing in Power Distribution: Introduction:

In the early power systems were mainly Neutral ungrounded due to the fact that the first ground fault did not require the tripping of the system. An unscheduled shutdown on the first ground fault was particularly undesirable for continuous process industries. These power systems required ground detection systems, but locating the fault often proved difficult. Although achieving the initial goal, the ungrounded system provided no control of transient over-voltages. A capacitive coupling exists between the system conductors and ground in a typical distribution system. As a result, this series resonant L-C circuit can create over-voltages well in excess of line-to-line voltage when subjected to repetitive re-strikes of one phase to ground. This in turn, reduces insulation life resulting in possible equipment failure. Neutral grounding systems are similar to fuses in that they do nothing until something in the system goes wrong. Then, like fuses, they protect personnel and equipment from damage. Damage comes from two factors, how long the fault lasts and how large the fault current is. Ground relays trip breakers and limit how long a fault lasts and Neutral grounding resistors limit how large the fault current is.

Importance of Neutral Grounding:

There are many neutral grounding options available for both Low and Medium voltage power systems. The neutral points of transformers, generators and rotating machinery to the earth ground network provides a reference point of zero volts. This protective measure offers many advantages over an ungrounded system, like,

- Reduced magnitude of transient over voltages
- Simplified ground fault location
- Improved system and equipment fault protection

- Reduced maintenance time and expense
- Greater safety for personnel
- Improved lightning protection
- Reduction in frequency of faults.

Method of Neutral Earthing:

There are five methods for Neutral earthing.

- Unearthed Neutral System
- Solid Neutral Earthed System
- Resistance Neutral Earthing System.

1) Low Resistance Earthing. 2) High Resistance Earthing.

- Resonant Neutral Earthing System.
- Earthing Transformer Earthing.

(1) Ungrounded Neutral Systems:

- In ungrounded system there is no internal connection between the conductors and earth.

However, as system, a capacitive coupling exists between the system conductors and the adjacent grounded surfaces. Consequently, the —ungrounded system|| is, in reality, a —capacitive grounded system|| by virtue of the distributed capacitance.

- Under normal operating conditions, this distributed capacitance causes no problems. In fact, it is beneficial because it establishes, in effect, a neutral point for the system; As a result, the phase conductors are stressed at only line-to-neutral voltage above ground.

But problems can rise in ground fault conditions. A ground fault on one line results in full line-to-line voltage appearing throughout the system. Thus, a voltage 1.73 times the normal voltage is present on all insulation in the system. This situation can often cause failures in older motors and transformers, due to insulation breakdown.

Advantage:

1. After the first ground fault, assuming it remains as a single fault, the circuit may continue in operation, permitting continued production until a convenient shut down for maintenance can be scheduled.

Disadvantages:

1. The interaction between the faulted system and its distributed capacitance may cause transient overvoltages (several times normal) to appear from line to ground during normal switching of a circuit having a line-to-ground fault (short). These over voltages may cause insulation failures at points other than the original fault.
2. A second fault on another phase may occur before the first fault can be cleared. This can result in very high line-to-line fault currents, equipment damage and disruption of both circuits.
3. The cost of equipment damage.
4. Complicate for locating fault(s), involving a tedious process of trial and error: first isolating the correct feeder, then the branch, and finally, the equipment at fault. The result is unnecessarily lengthy and expensive down downtime.

(2) Solidly Neutral Grounded Systems:

- Solidly grounded systems are usually used in low voltage applications at 600 volts or less.
- In solidly grounded system, the neutral point is connected to earth.

• Solidly Neutral Grounding slightly reduces the problem of transient over voltages found on the ungrounded system and provided path for the ground fault current is in the range of 25 to 100% of the system three phase fault current. However, if the reactance of the generator or transformer is too great, the problem of transient over voltages will not be solved.

While solidly grounded systems are an improvement over ungrounded systems, and speed up the location of faults, they lack the current limiting ability of resistance grounding and the extra protection this provides. To maintain systems health and safe, Transformer neutral is grounded and grounding conductor must be extend from the source to the furthest point of the system within the same raceway or conduit. Its purpose is to maintain very low impedance to ground faults so that a relatively high fault current will flow thus insuring that circuit breakers or fuses will clear the fault quickly and therefore minimize damage. It also greatly reduces the shock hazard to personnel

• If the system is not solidly grounded, the neutral point of the system would —float|| with respect to ground as a function of load subjecting the line-to-neutral loads to voltage unbalances and instability.

- The single-phase earth fault current in a solidly earthed system may exceed the three phase fault current. The magnitude of the current depends on the fault location and the fault resistance. One way to reduce the earth fault current is to leave some of the transformer neutrals unearthed.

Advantage:

- The main advantage of solidly earthed systems is low over voltages, which makes the earthing design common at high voltage levels (HV).

Disadvantage:

- This system involves all the drawbacks and hazards of high earth fault current: maximum damage and disturbances.
- There is no service continuity on the faulty feeder.
- The danger for personnel is high during the fault since the touch voltages created are high.

Applications:

- Distributed neutral conductor.
- 3-phase+neutral distribution.

(3)Resistance earthed systems:

- Resistance grounding has been used in three-phase industrial applications for many years and it resolves many of the problems associated with solidly grounded and ungrounded systems.
- Resistance Grounding Systems limits the phase-to-ground fault currents. The reasons for limiting the Phase to ground Fault current by resistance grounding are:
 - To reduce burning and melting effects in faulted electrical equipment like switchgear, transformers, cables, and rotating machines.
 - To reduce mechanical stresses in circuits/Equipments carrying fault currents.
 - To reduce electrical-shock hazards to personnel caused by stray ground fault.
 - To reduce the arc blast or flash hazard.
- To reduce the momentary line-voltage dip.
- To secure control of the transient over-voltages while at the same time.
- To improve the detection of the earth fault in a power system.
- Grounding Resistors are generally connected between ground and neutral of transformers, generators and grounding transformers to limit maximum fault current as per Ohms Law to a value which will not damage the equipment in the power system and allow sufficient flow of fault current to detect and operate Earth protective relays to clear the fault. Although it is possible to limit fault currents with high resistance Neutral grounding Resistors, earth short circuit currents can be extremely reduced. As a result of this fact, protection devices may not sense the fault.
- Therefore, it is the most common application to limit single phase fault currents with low resistance Neutral Grounding Resistors to approximately rated current of transformer and / or generator.
- In addition, limiting fault currents to predetermined maximum values permits the designer to selectively coordinate the operation of protective devices, which minimizes system disruption and allows for quick location of the fault.

There are two categories of resistance grounding:

- Low resistance Grounding.
- High resistance Grounding.

Ground fault current flowing through either type of resistor when a single phase faults to ground will increase the phase-to-ground voltage of the remaining two phases. As a result, conductor insulation and surge arrester ratings must be based on line-to-line voltage. This temporary increase in phase-to-ground voltage should also be considered when selecting two and three pole breakers installed on resistance grounded low voltage systems. Neither of these grounding systems (low or high resistance) reduces arc-flash hazards associated with phase-to-phase faults, but both systems significantly reduce or essentially eliminate the arc-flash hazards associated with phase-to-ground faults. Both types of grounding systems limit mechanical stresses and

reduce thermal damage to electrical equipment, circuits, and apparatus carrying faulted current. The difference between Low Resistance Grounding and High Resistance Grounding is a matter of perception and, therefore, is not well defined. Generally speaking high-resistance grounding refers to a system in which the NGR let-through current is less than 50 to 100 A. Low resistance grounding indicates that NGR current would be above 100 A. A better distinction between the two levels might be alarm only and tripping. An alarm-only system continues to operate with a single ground fault on the system for an unspecified amount of time. In a tripping system a ground fault is automatically removed by protective relaying and circuit interrupting devices. Alarm-only systems usually limit NGR current to 10 A or less

Rating of The Neutral grounding resistor:

- Voltage: Line-to-neutral voltage of the system to which it is connected.
- Initial Current: The initial current which will flow through the resistor with rated voltage applied.
- Time: The —on time|| for which the resistor can operate without exceeding the allowable temperature rise.

A) Low Resistance Grounded:

- Low Resistance Grounding is used for large electrical systems where there is a high investment in capital equipment or prolonged loss of service of equipment has a significant economic impact and it is not commonly used in low voltage systems because the limited ground fault current is too low to reliably operate breaker trip units or fuses. This makes system selectivity hard to achieve. Moreover, low resistance grounded systems are not suitable for 4-wire loads and hence have not been used in commercial market applications

A resistor is connected from the system neutral point to ground and generally sized to permit only 200A to 1200 amps of ground fault current to flow. Enough current must flow such that protective devices can detect the faulted circuit and trip it off-line but not so much current as to create major damage at the fault point.

Advantage:

- Limits phase-to-ground currents to 200-400A.

Since the grounding impedance is in the form of resistance, any transient over voltages are quickly damped out and the whole transient overvoltage phenomena is no longer applicable. Although theoretically possible to be applied in low voltage systems (e.g. 480V), significant amount of the system voltage dropped across the grounding resistor, there is not enough voltage across the arc forcing current to flow, for the fault to be reliably detected. For this reason, low resistance grounding is not used for low voltage systems (under 1000 volts line to-line).

- Reduces arcing current and, to some extent, limits arc-flash hazards associated with phase-to-ground arcing current conditions only.
- May limit the mechanical damage and thermal damage to shorted transformer and rotating machinery windings.

Disadvantages:

- Does not prevent operation of over current devices.
- Does not require a ground fault detection system.
- May be utilized on medium or high voltage systems.
- Conductor insulation and surge arrestors must be rated based on the line to-line voltage. Phase-to-neutral loads must be served through an isolation transformer.
- Used: Up to 400 amps for 10 sec are commonly found on medium voltage systems.

B)High Resistance Grounded:

- High resistance grounding is almost identical to low resistance grounding except that the ground fault current magnitude is typically limited to 10 amperes or less. High resistance grounding accomplishes two things.

The first is that the groundfault current magnitude is sufficiently low enough such that no appreciable damage is done at the fault point. This means that the faulted circuit need not be tripped off-line when the fault first occurs. Means that once a fault does occur, we do not know where the fault is located. In this respect, it performs just like an ungrounded system. The second point is it can control the transient overvoltage phenomenon present on ungrounded systems if engineered properly.

- Under earth fault conditions, the resistance must dominate over the system charging

capacitance but not to the point of permitting excessive current to flow and thereby excluding continuous operation

- High Resistance Grounding (HRG) systems limit the fault current when one phase of the system shorts or arcs to ground, but at lower levels than low resistance systems.
- In the event that a ground fault condition exists, the HRG typically limits the current to 5-10A.
- HRG's are continuous current rated, so the description of a particular unit does not include a time rating. Unlike NGR's, ground fault current flowing through a HRG is usually not of significant magnitude to result in the operation of an over current device. Since the ground fault current is not interrupted, a ground fault detection system must be installed.
- These systems include a bypass contactor tapped across a portion of the resistor that pulses (periodically opens and closes). When the contactor is open, ground fault current flows through the entire resistor. When the contactor is closed a portion of the resistor is bypassed resulting in slightly lower resistance and slightly higher ground fault current.

- To avoid transient over-voltages, an HRG resistor must be sized so that the amount of ground fault current the unit will allow to flow exceeds the electrical system's charging current. As a rule of thumb, charging current is estimated at 1A per 2000KVA of system capacity for low voltage systems and 2A per 2000KVA of system capacity at 4.16kV.
- These estimated charging currents increase if surge suppressors are present. Each set of suppressors installed on a low voltage system results in approximately 0.5 A of additional charging current and each set of suppressors installed on a 4.16kV system adds 1.5 A of additional charging current.
- A system with 3000KVA of capacity at 480 volts would have an estimated charging current of 1.5A. Add one set of surge suppressors and the total charging current increases by 0.5A to 2.0A. A standard 5A resistor could be used on this system. Most resistor manufacturers publish detailed estimation tables that can be used to more closely estimate an electrical system's charging current.

Advantages:

1. Enables high impedance fault detection in systems with weak capacitive connection to earth
2. Some phase-to-earth faults are self-cleared.
3. The neutral point resistance can be chosen to limit the possible over voltage transients to 2.5 times the fundamental frequency maximum voltage.
4. Limits phase-to-ground currents to 5-10A.
5. Reduces arcing current and essentially eliminates arc-flash hazards associated with phase-to-ground arcing current conditions only.
6. Will eliminate the mechanical damage and may limit thermal damage to shorted transformer and rotating machinery windings.
7. Prevents operation of over current devices until the fault can be located (when only one phase faults to ground).
8. May be utilized on low voltage systems or medium voltage systems up to 5kV. IEEE Standard 141-1993 states that —high resistance grounding should be restricted to 5kV class or lower systems with charging currents of about 5.5A or less and should not be attempted on 15kV systems, unless proper grounding relaying is employed||.
9. Conductor insulation and surge arrestors must be rated based on the line to-line voltage. Phase-to-neutral loads must be served through an isolation transformer.

Disadvantages:

1. Generates extensive earth fault currents when combined with strong or moderate capacitive connection to earth Cost involved.
2. Requires a ground fault detection system to notify the facility engineer that a ground fault condition has occurred.

(4) Resonant earthed system:

- Adding inductive reactance from the system neutral point to ground is an easy method of limiting the available ground fault from something near the maximum 3 phase short circuit capacity (thousands of amperes) to a relatively low value (200 to 800 amperes).
- To limit the reactive part of the earth fault current in a power system a neutral point reactor can be connected between the transformer neutral and the station earthing system.
- A system in which at least one of the neutrals is connected to earth through an
 1. Inductive reactance.
 2. Petersen coil / Arc Suppression Coil / Earth Fault Neutralizer.
- The current generated by the reactance during an earth fault approximately compensates the capacitive component of the single phase earth fault current, is called a resonant earthed system.
- The system is hardly ever exactly tuned, i.e. the reactive current does not exactly equal the capacitive earth fault current of the system.
- A system in which the inductive current is slightly larger than the capacitive earth fault current is over compensated. A system in which the induced earth fault current is slightly smaller than the capacitive earth fault current is under compensated
- However, experience indicated that this inductive reactance to ground resonates with the system shunt capacitance to ground under arcing ground fault conditions and creates very high transient over voltages on the system.
- To control the transient over voltages, the design must permit at least 60% of the 3 phase short circuit current to flow underground fault conditions.

Petersen Coils:

- A Petersen Coil is connected between the neutral point of the system and earth, and is rated so that the capacitive current in the earth fault is compensated by an inductive current passed by the Petersen Coil. A small residual current will remain, but this is so small that any arc between the faulted phase and earth will not be maintained and the fault will extinguish. Minor earth faults such as a broken pin insulator, could be held on the system without the supply being interrupted. Transient faults would not result in supply interruptions.
- Although the standard ‘Petersen coil’ does not compensate the entire earth fault current in a network due to the presence of resistive losses in the lines and coil, it is now possible to apply ‘residual current compensation’ by injecting an additional 180° out of phase current into the neutral via the Peterson coil. The fault current is thereby reduced to practically zero. Such systems are known as ‘Resonant earthing with residual compensation’, and can be considered as a special case of reactive earthing.
- Resonant earthing can reduce EPR to a safe level. This is because the Petersen coil can often effectively act as a high impedance NER, which will substantially reduce any earth fault currents, and hence also any corresponding EPR hazards

Advantages:

- Small reactive earth fault current independent of the phase to earth capacitance of the system.

- Enables high impedance fault detection.

Disadvantages:

- Risk of extensive active earth fault losses.
- High costs associated.

(5)Earthing Transformers: For cases where there is no neutral point available for Neutral Earthing (e.g. for a delta winding), an earthing transformer may be used to provide a return path for single phase fault currents. In such cases the impedance of the earthing transformer may be sufficient to act as effective earthing impedance. Additional impedance can be added in series if required. A special ‘zig-zag’ transformer is sometimes used for earthing delta windings to provide a low zero-sequence impedance and high positive and negative sequence impedance to fault currents.

UNIT II

OPERATING PRINCIPLES AND RELAY CHARACTERISTICS

2.1 Electromagnetic Relay

Electromagnetic relays are those relays which are operated by electromagnetic action. Modern electrical protection relays are mainly micro processor based, but still electromagnetic relay holds its place. It will take much longer time to be replaced the all electromagnetic relays by micro processor based static relays. So before going through detail of protection relay system we should review the various types of electromagnetic relays. Electromagnetic Relay Working

Practically all the relaying device are based on either one or more of the following types of electromagnetic relays.

1. Magnitude measurement,
2. Comparison,
3. Ratio measurement.

Principle of electromagnetic relay working is on some basic principles. Depending upon working principle the these can be divided into following types of electromagnetic relays.

1. Attracted Armature type relay,
2. Induction Disc type relay,
3. Induction Cup type relay,
4. Balanced Beam type relay,
5. Moving coil type relay,
6. Polarized Moving Iron type relay.

Attraction Armature Type Relay

Attraction armature type relay is the most simple in construction as well as its working principle. These types of electromagnetic relays can be utilized as either magnitude relay or ratio relay. These relays are employed as auxiliary relay, control relay, over current, under current, over voltage, under voltage and impedance measuring relays.



Hinged armature and plunger type constructions are most commonly used for these types of electromagnetic relays. Among these two constructional design, hinged armature type is more commonly used.

We know that force exerted on an armature is directly proportional to the square of the magnetic flux in the air gap. If we ignore the effect of saturation, the equation for the force experienced by the armature can be expressed as,

$$F = (KI^2 - K')$$

Where F is the net force, K' is constant, I is rms current of armature coil, and K' is the restraining force.

The threshold condition for relay operation would therefore be reached when $KI^2 = K'$.

If we observe the above equation carefully, it would be realized that the relay operation is dependent on the constants K' and K for a particular value of the coil current.

From the above explanation and equation it can be summarized that, the operation of relay is influenced by

1. Ampere – turns developed by the relay operating coil,
2. The size of air gap between the relay core and the armature,
3. Restraining force on the armature.

Construction of Attracted Type Relay

This relay is essentially a simple electromagnetic coil, and a hinged plunger. Whenever the coil becomes energized the plunger being attracted towards core of the coil. Some NO-NC (Normally Open and Normally Closed) contacts are so arranged mechanically with this plunger, that, NO contacts become closed and NC contacts become open at the end of the plunger movement. Normally attraction armature type relay is dc operated relay. The contacts are so arranged, that, after relay is operated, the contacts cannot return their original positions even after the armature is de energized. After relay operation, this types of electromagnetic relays are reset manually.

Attraction armature relay by virtue of their construction and working principle, is instantaneous in operation.

Induction Disc Type Relay

Induction disc type relay mainly consists of one rotating disc.

Induction Disc type Relay Working

Every induction disc type relay works on the same well known Ferraries principle. This principle says, a torque is produced by two phase displaced fluxes, which is proportional to the product of their magnitude and phase displacement between them. Mathematically it can be expressed as-

$$T = K\phi_1\phi_2 \sin\theta$$



The induction disc type relay is based on the same principle as that of an ammeter or a volt meter, or a wattmeter or a watt hour mater. In induction relay the deflecting torque is produced by the eddy currents in an aluminium or copper disc by the flux of an ac electromagnet. Here, an aluminium (or copper) disc is placed between the poles of an AC magnet which produces an alternating flux ϕ lagging from I by a small angle. As this flux links with the disc, there must be an induced emf E_2 in the disc, lagging behind the flux ϕ by 90° . As the disc is purely resistive, the induced current in the disc I_2 will be in phase with E_2 . As the angle between ϕ and I_2 is 90° , the net torque produced in that case is zero. As,

$$T = \phi I_2 \cos 90^\circ = 0$$

In order to obtain torque in induction disc type relay, it is necessary to produce a rotating field.

Pole Shading Method of Producing Torque in Induction Disc Relay

In this method half of the pole is surrounded with copper ring as shown. Let ϕ_1 is the flux of unshaded portion of the pole. Actually total flux divided into two equal portions when the pole is divided into two parts by a slot.

$$\text{Total flux, } \phi = \phi_1 + \phi_2$$

As the one portion of the pole is shaded by copper ring. There will be induced current in the shade ring which will produce another flux ϕ_2' in the shaded pole. So, resultant flux of shaded pole will be vector sum of ϕ_1 and ϕ_2 . Say it is ϕ_2 , and angle between ϕ_1 and ϕ_2 is θ . These two fluxes will produce a resultant torque,

$$T = K \phi_1 \phi_2 \sin \theta$$

There are mainly three types of shape of rotating disc are available for induction disc type relay. They are spiral shaped, round and vase shaped, as shown. The spiral shape is done to compensate against varying restraining torque of the control spring which winds up as the disc rotates to close its contacts. For most designs, the disc may rotate by as much as 280° . Further, the moving contact on the disc shift is so positioned that it meets the stationary contacts on the relay frame when the largest radius section of the disc is under the electromagnet. This is done to ensure satisfactory contact pressure in induction disc type relay.

Where high speed operation is required, such as in differential protection, the angular travel of the disc is considerably limited and hence circular or even vane types may be used in induction disc type electromagnetic relay.

Some time it is required that operation of an induction disc type relay should be done after successful operation of another relay. Such as inter locked over current relays are generally used for generator and bus bar protection. In that case, the shading band is replaced by a shading coil. Two ends of that shading coil are brought out across a normally open contact of other control device or relay. Whenever the latter is operated the normally open contact is closed and makes the shading coil short circuited. Only after that the over current relay disc starts rotating.

One can also change the time / current characteristics of an induction disc type relay, by deploying variable resistance arrangement to the shading coil.

Induction disc relay fed off a negative sequence filter can also be used as Negative-sequence protection device for alternators.

Induction Cup Type Relay

Induction cup type relay can be considered as a different version of induction disc type relay. The working principle of both type of relays are more or less same. Induction cup type relay are used where, very high speed operation along with polarizing and/or differential winding is requested. Generally four pole and eight pole design are available. The number of poles depends upon the number of winding to be accommodated.

The inertia of cup type design is much lower than that of disc type design. Hence very high speed operation is possible in induction cup type relay. Further, the pole system is designed to give maximum torque per KVA input. In a four pole unit almost all the eddy currents induced in the cup by one pair of poles appear directly under the other pair of poles – so that torque / VA is about three times that of an induction disc with a c-shaped electromagnet.

Induction cup type relay is practically suited as directional or phase comparison units. This is because, besides their sensitivity, induction cup relay have steady non vibrating torque and their parasitic torque due to current or voltage alone are small.

Induction Cup Type-Directional or Power Relay

It in a four pole induction cup type relay, one pair of poles produces flux proportional to voltage and other pair of poles produces flux proportional to current. The vector diagram is given below,

The torque $T_1 = K\phi_{v_i}\phi_{i_i}\sin(90^\circ - \theta)$ assuming flux produced by the voltage coil will lag 90° behind its voltage. By design, the angle can be made to approach any value and a torque equation $T = K.E.I.\cos(\phi - \theta)$ obtained, where θ is the E - I system angle.

Accordingly, induction-cup type relay can be designed to produced maximum torque When system angle $\theta = 0^\circ$ or 30° or 45° or 60° . The former is known as power relays as they produce maximum torque when $\theta = 0^\circ$ and latter are known as directional relays – they are used for directional discrimination in protective schemes under fault conditions, as they are designed to produce maximum torque at faulty conditions.

2.2 Over Current Relay Working Principle Types

In an over current relay or o/c relay the actuating quantity is only current. There is only one current operated element in the relay, no voltage coil etc. are required to construct this protective relay.

Working Principle of Over Current Relay

In an over current relay, there would be essentially a current coil. When normal current flows through this coil, the magnetic effect generated by the coil is not sufficient to move the moving element of the relay, as in this condition the restraining force is greater than deflecting force. But when the current through the coil increased, the magnetic effect increases, and after certain level of current, the deflecting force generated by the magnetic effect of the coil, crosses the restraining force, as a result, the moving element starts moving to change the contact position in the relay.

Although there are different **types of over current relays but basic working principle of over current relay** is more or less same for all.

Types of Over Current Relay

Depending upon time of operation, there are various **types of OC relays**, such as,

1. **Instantaneous over current relay.**
2. **Definite time over current relay.**
3. **Inverse time over current relay.**

Inverse time over current relay or simply inverse OC relay is again subdivided as inverse definite minimum time (IDMT), very inverse time, extremely inverse time over current relay or OC relay.

Instantaneous Over Current Relay

Construction and working principle of **instantaneous over current relay quite simple.**

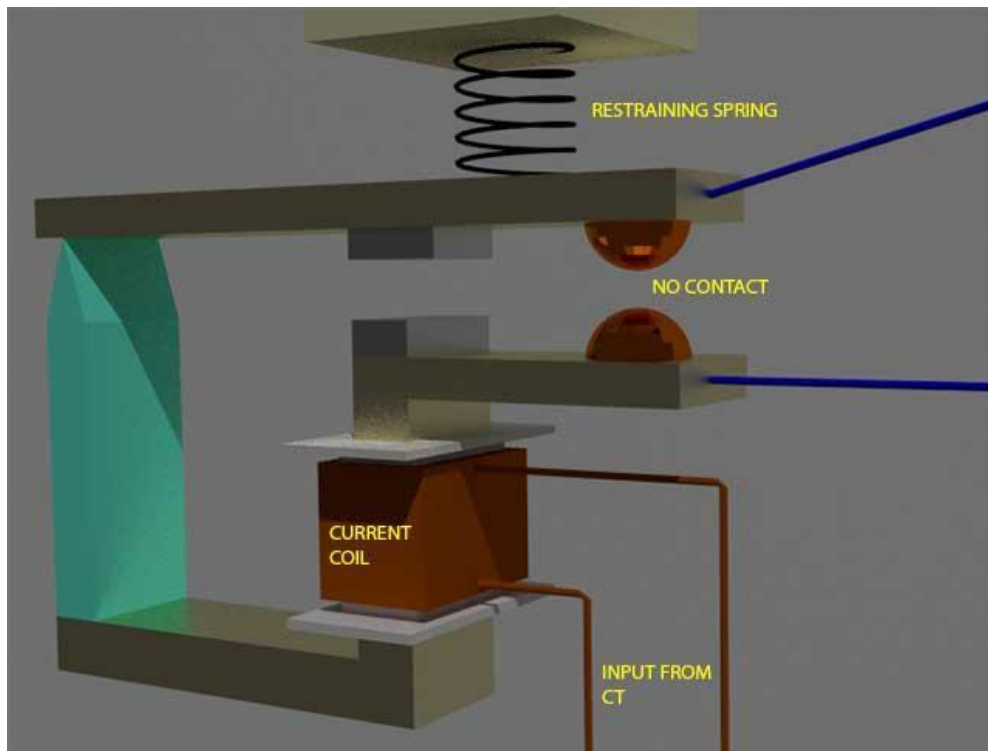

Here generally a magnetic core is wound by current coil. A piece of iron is so fitted by hinge support and restraining spring in the relay, that when there is not sufficient current in the coil, the NO contacts remain open. When current in the coil crosses a present value, the attractive force becomes sufficient to pull the iron piece towards the magnetic core and consequently the No contacts are closed.

The preset value of current in the relay coil is referred as pick up setting current. This relay is referred as instantaneous over current relay, as ideally, the relay operates as soon as the current in the coil gets higher than pick up setting current. There is no intentional time delay applied. But there is always an inherent time delay which can not be avoided practically. In practice the operating time of an instantaneous relay is of the order of a few milliseconds. Fig.

2.3 Directional Over Current Relays

1. When fault current can flow in both the directions through the relay, at its location. Therefore, it is necessary to make the relay respond for a particular defined direction, so that proper discrimination is possible. This can be achieved by introduction of directional control elements.

2. These are basically power measuring devices in which the system voltage is used as a reference for establishing the relative phase of the fault current.

Basically, an AC directional relay can recognize certain difference in phase angle between two quantities, just as a D.C. directional relay recognize difference in polarity

The polarizing quantity of a directional relay

1. It is the reference against which the phase angle of the other quantity is compared. Consequently the phase angle of the polarizing quantity must remain fixed when other quantity suffers wide change in phase angle.

2. The voltage is chosen as the “polarizing” quantity in the current-voltage induction type directional relay.

3. Four pole induction cup construction is normally used.

2.4 Distance relay

Distance relay is used for the protection of transmission line & feeders In a distance relay, instead of comparing the local line current with the current at far end of line, the relay compares the local current with the local voltage in the corresponding phase or suitable components of them

Principle of operation of distance relay

1. The basic principle of measurement involves the comparison of fault current seen by the relay with the voltage at relaying point; by comparing these two quantities.

2. It is possible to determine whether the impedance of the line up to the point of fault is greater than or less than the predetermined reach point impedance

There are two types of torques

1. Restraining torque

$$T_r \propto V_F^2$$

2. Operating torque

$$T_o \propto I_F^2$$

The relay trips when T_o greater than T_r

$$KI_F^2 > V_F^2$$

$$\frac{V_F}{I_F} < \sqrt{K}$$

The constant K depends on the design of the electromagnets.

Types of distance relay Distance relays are classified depending on their operating characteristic in the R-X plane

- Impedance Relay
- Mho Relay
- Reactance Relay

2.5 IMPEDANCE RELAY:

The torque equation T, for such a relay the current actuates the operating torque and the voltage actuates the restraining torque, with the usual spring constant K4.

$$T = K_1 I^2 + K_2 V^2 + K_4$$

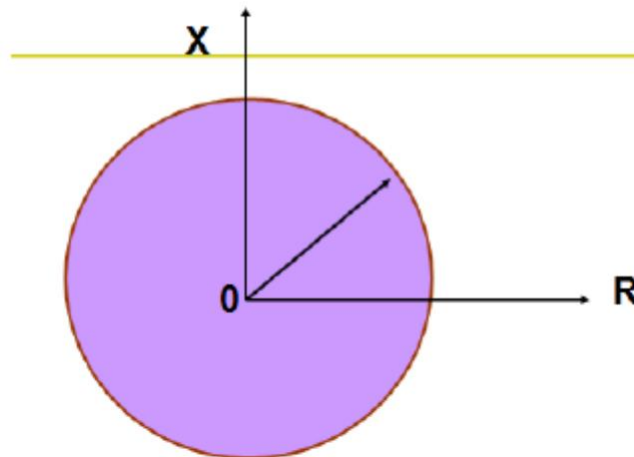

Considering K_2 to be negative (as it produces the restraining torque) and neglecting the torque component due to spring, the equation represents a circle in the R-X plane.

DISADVANTAGE OF IMPEDANCE RELAY

1. It is not directional.
2. It is affected by the Arc resistance
3. It is highly sensitive to oscillations on the power system, due to large area covered by its circular characteristic

2.6 Differential Relay

One of the most prevalent and successful method of protecting a circuit is to arrange relays to compare the currents entering and leaving it, which should be the same under normal conditions and during an external fault. Any difference current must be flowing in to a fault within the protected circuit

Principle of circulating current differential (MERZ-PRIZE) protection

The figure below illustrates the principle of differential protection of generator and transformer, X is the winding of the protected machine. Where there is no internal fault, the current entering in X is equal in phase and magnitude to current leaving X. The CT's have such a ratio that during the normal conditions or for external faults (Through Faults) the secondary current of CT's are equal. These current say I_1 and I_2 circulate in the pilot wire. The polarity connections are such the current I_1 and I_2 are in the same direction of pilot wire during normal condition or external faults. Relay operation coil is connected at the middle of pilot wires. Relay unit is of over current type

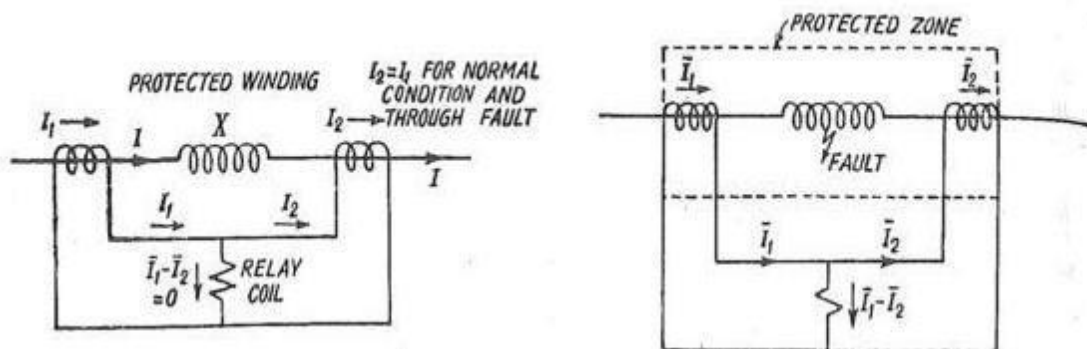

During normal condition and external fault the protection system is balanced and the CT's ratios are such that secondary currents are equal. These current circulate in pilot wires. The

vector differential current $I_1 - I_2$ which flow through the relay coil is zero. $I_1 - I_2 = 0$ (normal condition or external faults) This balance is disturbed for internal faults. When fault occurs in the protected zone, the current entering the protected winding is no more equal to the leaving the winding because some current flows to the fault. The differential $I_1 - I_2$ flows through the relay operating coil and the relay operates if the operating torque is more than the restraining torque. The current I_1 and I_2 circulate in the secondary circuit. Hence CT's does not get damaged. Polarities of CT's should be proper, otherwise the currents I_1 and I_2 would add up even for normal condition and mal operate the relay.

Differential Protection current balance

- When this system is applied to electrical equipment (Generator stator windings, Transformer, Bus bars etc.) it is called differential current protection.
- When it is applied to lines and cables it is called pilot differential protection because pilot wires or an equivalent link or channel is required to bring the current to the relay from the remote end of the line.

The CTs at both ends of the protected circuit connected so that for through load or through fault conditions current circulates between the interconnected CTs. The over-current relay is normally connected across equipotential points and therefore doesn't operate.

- Circulating current balance methods are widely used for apparatus protection where CTs are within the same substation area and interconnecting leads between CTs are short (e.g. generator stator windings, Transformer, Bus bars etc.)

- The circulating current balance method is also called longitudinal differential protection or Merz-Price differential protection system.

- The current in the differential relay would be proportional to the phasor difference between the currents that enter and leave the protected circuit. If the current through the relay exceeds the pick-up value, then the relay will operate.

Demerits of a Differential Relay(Merz Price Scheme)

- **Unmatched characteristics of C.T.s :**

Though the saturation is avoided, there exist difference in the C.T. characteristics due to ratio error at high values of short circuit currents. This causes an appreciable difference in the secondary currents which can operate the relay. So the relay operates for through external faults. This difficulty is overcome by using percentage differential relay. In this relay, the difference in current due to the ratio error exists and flows through relay coil. But at the same time the average current ($I_1 + I_2/2$) flows through the restraining coil which produces enough restraining torque. Hence relay becomes inoperative for the through faults.

- **Ratio change due to tap change:**

To alter the voltage and current ratios between high voltage and low voltage sides of a power transformer, a tap changing equipment is used. This is an important feature of a power transformer. This equipment effectively alters the turns ratio. This causes unbalance on both sides. To compensate for this effect, the tapping can be provided on C.T.s also which are to be varied similar to the main power transformer. But this method is not practicable. The percentage differential relays ensure the stability with respect to the amount of unbalance occurring at the extremities of the tap change range.

- **Difference in lengths of pilot wires:**

Due to the difference in lengths of the pilot wires on both sides, the unbalance condition may result. The difficulty is overcome by connecting the adjustable resistors in pilot wires on both sides. These are called balancing resistors. With the help of these resistors, equipotential points on the pilot wires can be adjusted. In percentage differential relays the taps are provided on the operating coil and restraining coil to achieve an accurate balance.

- **Magnetizing current inrush:**

When the transformer is energized, the condition initially is of zero induced E.m.f. A transient inflow of magnetizing current occurs in to the transformer. This current is called magnetizing inrush current. This current may be as great as 10 times the full load current of the transformer. This decays very slowly and is bound to operate differential protection of the transformer falsely, because of the temporary difference in magnitude of the primary and secondary currents.

The factors which affect the magnitude and direction of the magnetizing inrush current can be one of the following reasons.

- a. Size of the transformer.
- b. Size of the power system
- c. Type of magnetic material used for the core.
- d. The amount of residual flux existing before energizing the transformer.
- e. The method by which transformer is energized.

If the transformer is energized when the voltage wave is passing through zero, the magnetizing current inrush is maximum. At this instant, the current and flux should be maximum in highly inductive circuit. And in a half wave flux reversal must take place to attain maximum value in the other half cycles. If the residual flux exists, the required flux may be in same or opposite direction. Due to this magnetizing current inrush is less or more. If it is more, it is responsible to saturate the core which further increases its component. This current decays rapidly for first few cycles and then decays slowly. The time constant L/R of the circuit is variable as inductance of circuit varies due to the change in permeability of the core. The losses in the circuit damp the inrush currents. Depending on the size of the transformer, the time constant of inrush current varies from 0.2 sec to 1 sec. The waveforms of magnetizing inrush current in three phases are shown in the figure below.

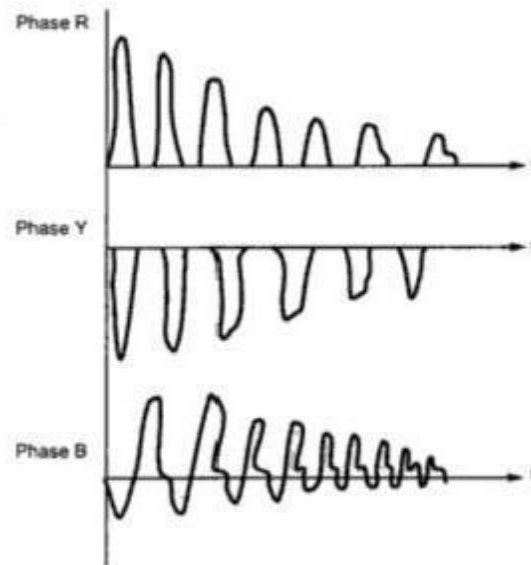

2.7 Static relays

Advantages of static relays

- Due to the amplification of energizing signals obtainable, the sources need only provide low power. Therefore the size of the associated current and voltage transformers could be reduced.
- Improved accuracy and selectivity.
- Fast operation of relays and hence fast clearance of faults.
- Flexibility of circuitry would allow new and improved characteristics.
- The relays would be unaffected by the number of operations.

Basic circuits employed

- Timers
- Phase comparators
- Amplitude Comparator
- Level detectors
- Integrators
- Polarity detectors

High reliability operational amplifiers are used for realizing the basic components of static relays.

UNIT III

APPARATUS PROTECTION

PROTECTION OF FEEDERS

3.1 Over current and earth fault protection

It is customary to have two elements of over current and one element of earth fault protection system in the most elementary form of protection of three phase feeders. Different types of feeders employ the over current protection along with the directional relay so that proper discrimination of an internal fault is possible. Some examples are illustrated below.

Application of directional relays to parallel feeders

It may be seen from the below given parallel feeders that the relays placed at the load side of both the lines use directional element which respond to a direction away from the bus bars. Similarly, the relays placed at the source side do not require any directional element.

A similar concept of discrimination is also utilized in the below given ring main feeder and a feeder fed from both the sides. It can be observed that relays placed near the bus connecting the sources, don not have any directional feature, where as the rest of the buses, respond to a direction always away from the source. It is good practice to locate a fault anywhere among different sections of the feeders and check whether that particular section only is isolated without disrupting the power flow in other sections.

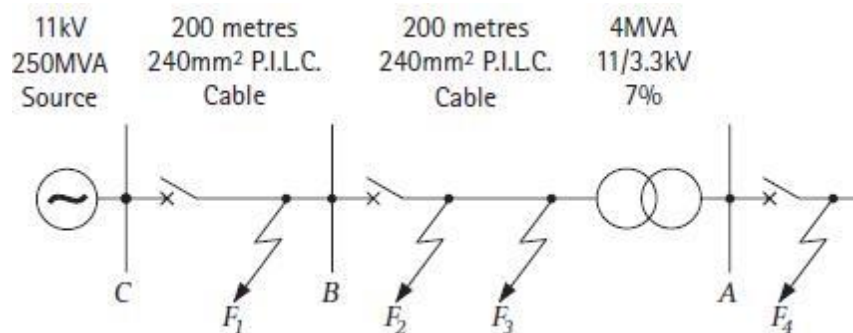

Pilot wire schemes for feeder protection

In differential protection scheme, the current entering at one end of the line and leaving from other end of the line is compared. The pilot wires are used to connect the relays. Under normal working condition, the two currents at both ends are equal and pilot wires do not carry any current, keeping relays inoperative. Under an internal fault condition, the two currents at both the ends are no longer same, this causes circulating current flow through pilot wires and

makes the relay to trip. The various schemes used with this method of protection are, 1. Merz-Price Voltage Balance System 2. Translay Scheme

Merz-Price Voltage Balance System

The figure below shows Merz-Price voltage balance system used for the three phase feeders.

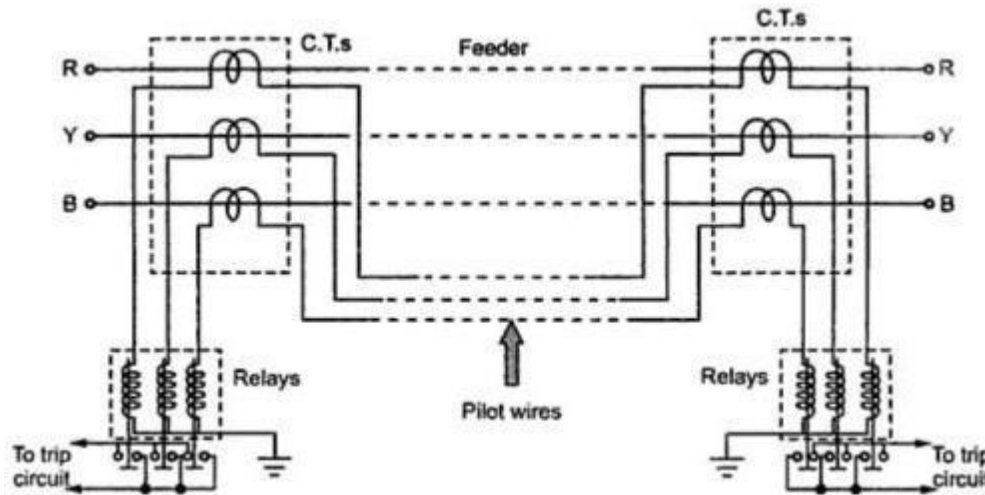

Under normal condition, current entering the line at one end is equal to current leaving from the other end. Therefore, equal and opposite voltages are induced in the secondaries of C.T.s. at the two ends resulting in no current flow, through the relay. Under fault condition, two currents at the two ends are different. Thus the secondary voltages of both the end C.T.s differ from each other. This circulates a circulating current through the pilot wires and the relays. Thus the relays trip the circuit breakers to isolate the faulty section.

The advantages of this method are as follows

1. It can be used for parallel as well as ring main system.
2. It provides instantaneous protection to ground faults.

The limitations of this method are as follows

1. The C.T.s used must match accurately.
2. The pilot wires must be healthy without discontinuity.
3. Economically not suitable as the cost is high due to long pilot wires.
4. Due to long pilot wires, capacitive effects adversely bias the operation of the relays.
5. The large voltage drop in the pilot wires requiring better insulation.

Translay Scheme

The translay relay is another type of differential relay. The arrangement is similar to overcurrent relay but the secondary winding is not closed on itself. Additionally copper ring or copper shading bands are provided on the central limb as shown in the figure below.

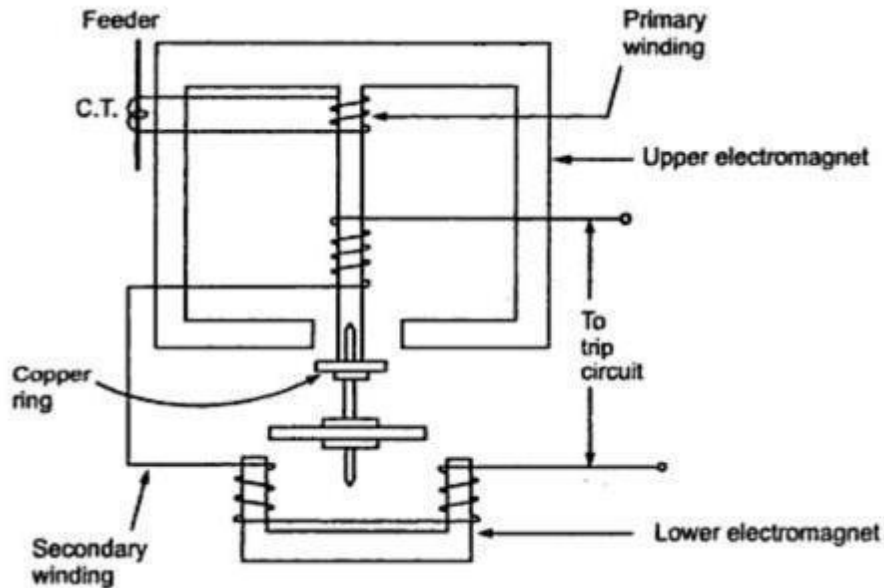

Role of copper ring:

Mainly relays may operate because of unbalance in the current transformers. The copper rings are so adjusted that the torque due to current induced in the copper ring due to primary winding of relay is restraining and do not allow the disc to rotate. It is adjusted just to neutralize the effect of unbalance existing between the current transformers. The copper rings also neutralize the effect of pilot capacitive currents. Though the feeder current is same at two ends, a capacitive current may flow in the pilots. This current leads the secondary voltage by 90° . The copper rings are adjusted such that no torque is exerted on the disc, due to such capacitive pilot currents. Therefore in this scheme the demerits of pilot relaying scheme is somewhat taken care of.

The **advantages** of this scheme are,

1. Only two pilot wires are required.
2. The cost is very low.
3. The current transformers with normal design can be employed.
4. The capacitive effects of pilot wire currents do not affect the operation of the relays.

Carrier Current unit protection system

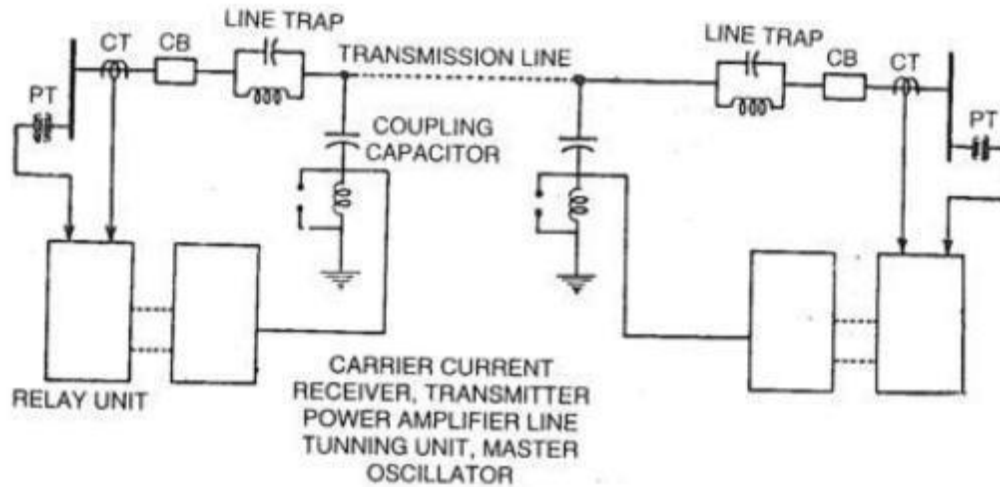

Schematic diagram of the carrier current scheme is shown below. Different basic components of the same are discussed below. The Coupling capacitor These coupling capacitors (CU) which offer low reactance to the higher frequency carrier signal and high reactance to the power frequency signal. Therefore, it filters out the low (power) frequency and allows the high frequency carrier waves to the carrier current equipments. A low inductance is connected to the CU, to form a resonant circuit.

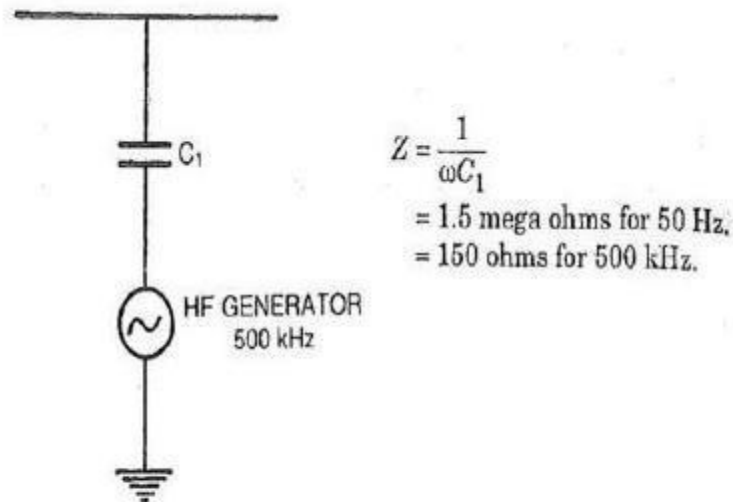

Wave Traps

The Wave traps (also known as Line Trap) are inserted between the busbar and the connection of the CU. These traps are L and C elements connected in parallel, and they are tuned in such a manner that they offer low reactance to the power frequency signals and high reactance to the carrier waves. They ensure that neither of these different frequency signals get mixed up before being received at the bus bar. Both the CU and the Wave traps are protected from switching and lightning surges, with the help suitably designed Spark Gaps or Varistors. Frequency spacing Different frequencies are used in adjacent lines and the wave traps ensure that carrier signals of other lines do not enter a particular line section. Therefore, proper choice of frequency bands for different lines are adopted.

Transmitter Unit

In a Transmitter unit, the carrier frequency in the range of 50 to 500 KHz of constant magnitude is generated in the oscillator, which is fed to an amplifier. Amplification is required to overcome any loss in the coupling equipments, weather conditions, Tee connections in the lines of different size and length. The amplifier and the oscillators are constantly energized and a connection is made between the two with the help of a control unit.

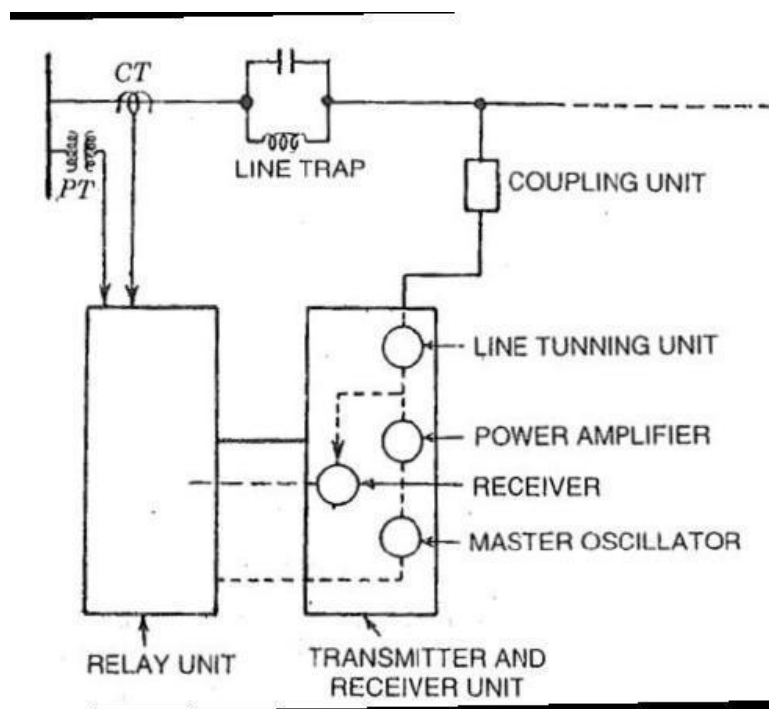

The Receiver unit consists of an attenuator and a Band pass filter, which restricts the acceptance of any unwanted signals. The unit also has matching transformer to match the line impedance and that of the receiver unit.

3.2 TRANSFORMER PROTECTION

INTRODUCTION

- The power transformer is one of the most important links in a power transmission and distribution system.
- It is a highly reliable piece of equipment. This reliability depends on
 - adequate design
 - careful erection
 - proper maintenance
 - application of protection system.

PROTECTION EQUIPMENT INCLUDES

1. Surge diverters
2. Gas relay: It gives early warning of a slowly developing fault, permitting shutdown and repair before severe damage can occur.
3. Electrical relays.

- The choice of suitable protection is also governed by economic considerations.

Although this factor is not unique to power transformers, it is brought in prominence by the wide range of transformer ratings used(few KVA to several hundreds MVA)

- Only the simplest protection such as fuses can be justified for transformers of lower ratings.
- for large transformers best protection should be provided.

TYPES OF FAULTS AFFECTING POWER TRANSFORMER

- THROUGH FAULTS
 - a) Overload conditions.
 - b) External short-circuit conditions.

The transformer must be disconnected when such faults occur only after allowing a predetermined time during which other protective gears should have operated.

- INTERNAL FAULTS

The primary protection of a power transformer is intended for conditions which arises as a result of faults inside the protection zone.

1. Phase-to-earth fault or phase- to- phase fault on HV and LV external terminals
2. Phase-to-earth fault or phase-to- phase fault on HV and LV windings.
3. Interturn faults of HV and LV windings.
4. Earth fault on tertiary winding, or short circuit between turns of a tertiary windings.

5. So called „incipient“ faults which are initially minor faults, causing gradually developing fault. These types of faults are not easily detectable at the winding terminals by unbalance current or voltage.

NATURE & EFFECT OF TRANSFRMER FAULTS

A faults on transformer winding is controlled in magnitude by

- Source & neutral earthing impedance
- Leakage reactance of the transformer
- Position of the fault on the winding.

Following distinct cases are examined below (1) Star connected winding with neutral point earthed through an impedance

Earth fault on resistance earthed star winding

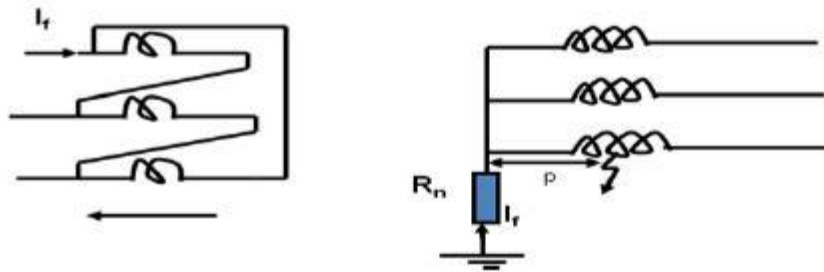

Transformer differential protection

Basic discussions related to the Merz-Price Scheme and its limitations which are taken care by the biased differential scheme, are omitted for repetition

Basic considerations

a. Transformation ratio

- The nominal currents in the primary and secondary sides of the transformer vary in inverse ratio to the corresponding voltages. This should be compensated for by using different transformation ratios for the CTs on the primary and secondary sides of the transformer.

b. Current Transformer Connections

- When a transformer is connected in star/delta, the secondary current has a phase shift of 30° relative to the primary
- This phase shift can be offset by suitable secondary CT connections

- The zero-sequence currents flowing on the star-side of the transformer will not produce current outside the delta on the other side. The zero sequence current must therefore be eliminated from the star-side by connecting the CTs in delta.
- • The CTs on delta side should be connected in star in order to give 300 phase shift.
- • When CTs are connected in delta, their secondary ratings must be reduced to 1/3 times the secondary ratings of the star-connected transformer, in order that the currents outside the delta may balance with the secondary currents of the star-connected CTs.
- • If transformers were connected in star/star, the CTs on both sides would need be connected in delta-delta.

c. Bias to cover tap-changing facility and CT mismatch

- • If the transformer has the benefit of a tap changer, it is possible to vary its transformation ratio for voltage control.
- • The differential protection system should be able to cope with this variation.
- • This is because if the CTs are chosen to balance for the mean ratio of the power transformer, a variation in ratio from the mean will create an unbalance proportional to the ratio change. At maximum through fault current, the spill output produced by the small percentage unbalance may be substantial
- • Differential protection should be provided with a proportional bias of an amount which exceeds in effect the maximum ratio deviation. This stabilizes the protection under through fault conditions while still permitting the system to have good basic sensitivity.

d. Magnetization Inrush

- The magnetizing inrush produces a current flow into the primary winding that does not have any equivalent in the secondary winding. The net effect is thus similar to the situation when there is an internal fault on the transformer.
- Since the differential relay sees the magnetizing current as an internal fault, it is necessary to have some method of distinguishing between the magnetizing current and the fault current using one or all of the following methods.
- Using a differential relay with a suitable sensitivity to cope with the magnetizing current, usually obtained by a unit that introduces a time delay to cover the period of the initial inrush peak.
- • Using a harmonic-restraint unit, or a supervisory unit, in conjunction with a differential unit.
- • Inhibiting the differential relay during the energizing the transformer.

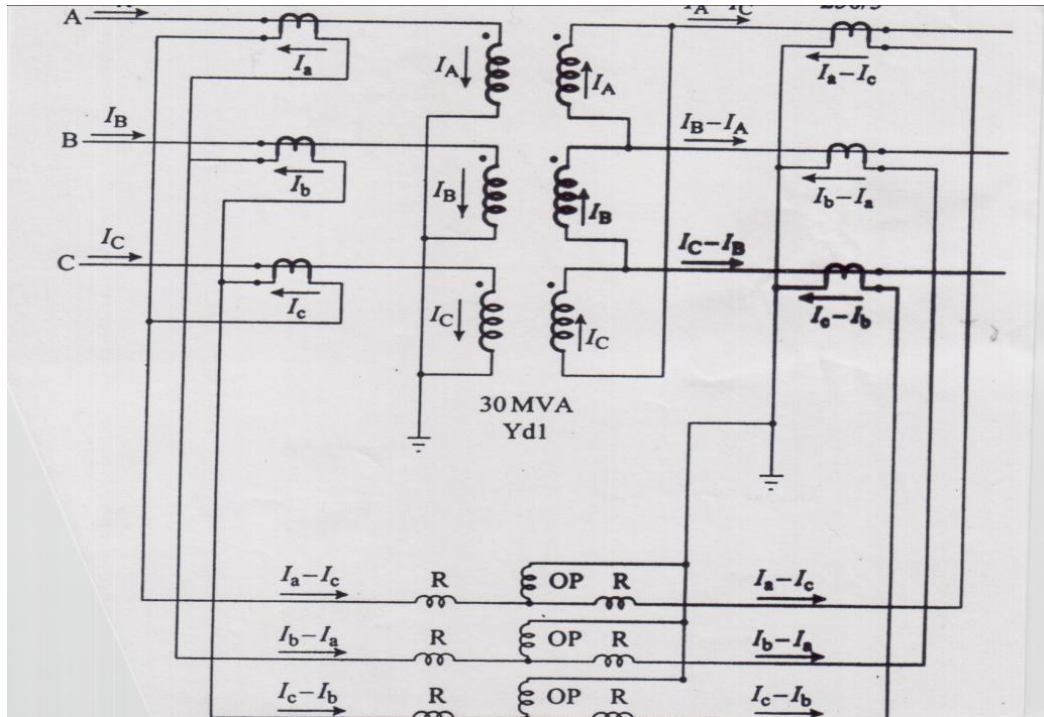

Compared to the differential protection used in generators, there are certain important points discussed below which must be taken care of while using such protection for the power transformers.

1. In a power transformer, the voltage rating of the two windings is different. The high voltage winding is low current winding while low voltage winding is high current winding. Thus there always exists difference in current on the primary and secondary sides of the power transformer. Hence if C.T.s of same ratio are used on two sides, then relay may get operated through there is no fault existing.

To compensate for this difficulty, the current ratios of C.T.s on each side are different. These ratios depend on the line currents of the power transformer and the connection of C.T.s. Due to the different turns ratio, the currents fed into the pilot wires from each end are same under normal conditions so that the relay remains inoperative. For example if K is the turns ratio of a power transformer then the ratio of C.T.s on low voltage side is made K times greater than that of C.T.s on high voltage side.

2. In case of power transformers, there is an inherent phase difference between the voltages induced in high voltage winding and low voltage winding. Due to this, there exists a phase difference between the line currents on primary and secondary sides of a power transformer. This introduces the phase difference between the C.T. secondary currents, on the two sides of a power transformer. Through the turns ratio of C.T.s are selected to compensate for turns ratio of transformer, a differential current may result due to the phase difference between the currents on two sides. Such a different current may operate the relay though there is no fault. Hence it is

necessary to correct the phase difference. To compensate for this, the C.T. connections should be such that the resultant currents fed into the pilot wires from either sides are displaced in phase by an angle equal to the phase shift between the primary and secondary currents. To achieve this, secondaries of C.T.s on star connected side of a power transformer are connected in delta while the secondaries of C.T.s on delta connected side of a power transformer are connected in star.

Buchholz relay

All faults below the oil in transformer result in the localized heating & breakdown of the oil, some degree of arcing will always take place in a winding fault & the resulting decomposition of it will release gases such as hydrogen, carbon monoxide & hydrocarbons.

- When the fault is of a very minor type, such as hot joints gas is released slowly, but a major fault involving severe arcing causes rapid release of large volumes of gas as well as oil vapour.
- Such incipient faults of smaller or larger magnitudes can be detected by a gas actuated relay known as Bucholtz Relay.

The Bucholtz Relay is contained in a cast housing which is connected as shown below between the conservator tank and main tank of the transformer.

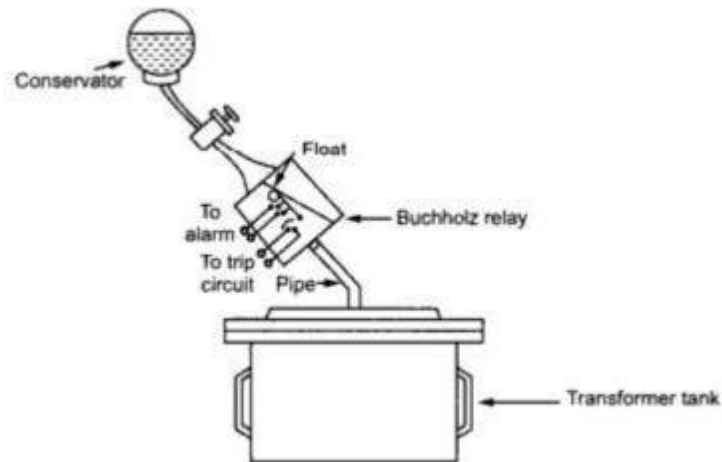

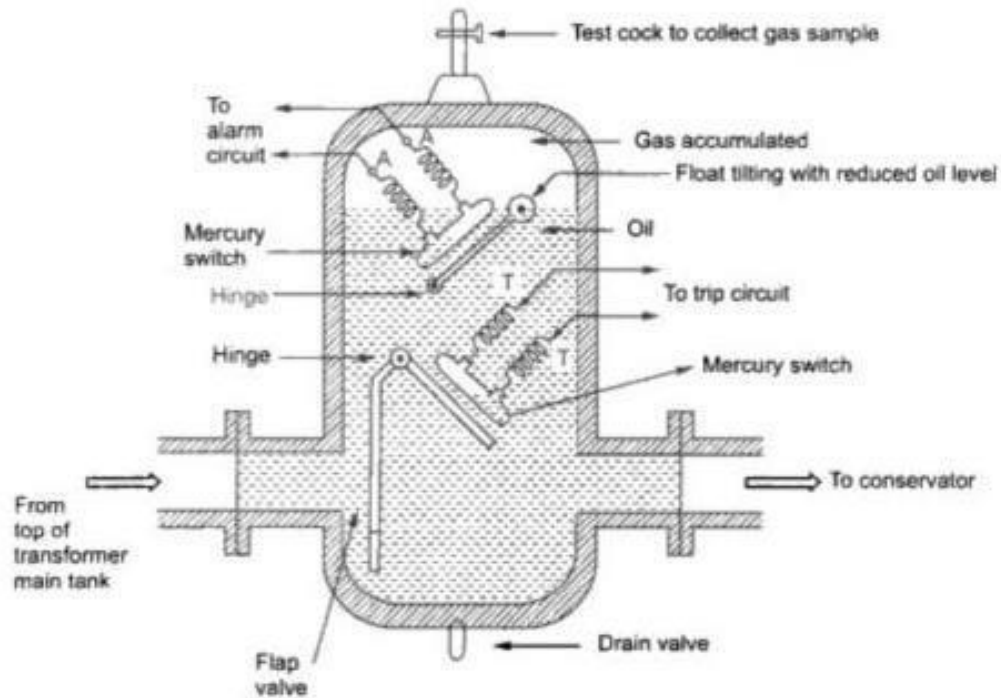

Under normal conditions, the Buchholz relay is full of oil. It consists of a cast housing containing a hinged hollow float. A mercury switch is attached to a float. The float being rotated in the upper part of the housing. Another hinged flap valve is located in the lower part which is directly in the path of the oil between tank and the conservator. Another mercury switch is attached to a flap valve. The float closes the alarm circuit while the lower flap valve closes the trip circuit in case of internal faults.

Operation

There are many types of internal faults such as insulation fault, core heating, bad switch contacts, faulty joints etc. which can occur. When the fault occurs the decomposition of oil in the main tank starts due to which the gases are generated. As mentioned earlier, major component of such gases is hydrogen. The hydrogen tries to rise up towards conservator but in its path it gets accumulated in the upper part of the Buchholz relay. Through passage of the gas is prevented by the flap valve.

When gas gets accumulated in the upper part of housing, the oil level inside the housing falls. Due to which the hollow float tilts and closes the contacts of the mercury switch attached to it. This completes the alarm circuit to sound an alarm. Due to this operator knows that there is some incipient fault in the transformer. The transformer is disconnected and the gas sample is tested. The testing results give the indication, what type of fault is started developing in the transformer.

Hence transformer can be disconnected before grows into a serious one. The alarm circuit does not immediately disconnect the transformer but gives only an indication to the operator. This is because sometimes bubbles in the oil circulating system may operate the alarm circuit even though actually there is no fault. However if a serious fault such as internal short circuit between phases, earth fault inside the tank etc. occurs then the considerable amount of gas gets generated. In that case, due to a fast reduction in the level of oil, the pressure in the tank increases. Due to this the oil rushes towards the conservator. While doing so it passes through the relay where flap valve is present. The flap valve gets deflected due to the rushing oil and operates the mercury switch, thereby energizing the trip circuit which opens the circuit breaker of transformer is totally disconnected from the supply. The connecting pipe between the tank and the conservator should be as straight as possible and should slope upwards conservator at a small angle from the horizontal. This angle should be around 100. For the economic considerations, Buchholz relays are not provided for the transformer having rating below 500 KVA.

Advantages

The various advantages of the Buchholz relay are,

1. Normally a protective relay does not indicate the appearance of the fault. It operates when fault occurs. But Buchholz relay gives an indication of the fault at very early stage, by anticipating the fault and operating the alarm circuit. Thus the transformer can be taken out of service before any type of serious damage occurs.
2. It is the simplest protection in case of transformers.

Limitations

The various limitation of the Buchholz relay are,

1. Can be used only for oil immersed transformers having conservator tanks.
2. Only faults below oil level are detected.
3. Setting of the mercury switches cannot be kept too sensitive otherwise the relay can operate due to bubbles, vibration, earthquakes mechanical shocks etc.
4. The relay is slow to operate having minimum operating time of 0.1 seconds and average time of 0.2 seconds.

Applications

The following types of transformer faults can be protected by the Buchholz relay and are indicated by alarm:

1. Local overheating
2. Entrance of air bubbles in oil
3. Core bolt insulation failure
4. Short circuited laminations
5. Loss of oil and reduction in oil level due to leakage

6. Bad and loose electrical contacts
7. Short circuit between phases
8. Winding short circuit
9. Bushing puncture
10. Winding earth fault.

3.3 Generator protection

INTRODUCTION

- The range of size of generators extends from a few hundred KVA to more than 500MVA
- Small and Medium sized sets may be directly connected to the distribution system

A larger unit is usually associated with an individual transformer, through which the set is coupled to the EHV transmission system. No switchgear is provided between the generator and transformer, which are treated as a unit.

Biased Differential scheme (Merz-Price Scheme) for protection of Generators.

This is most commonly used protection scheme for the alternator stator windings. The scheme is also called biased differential protection and percentage differential protection. The figure below shows a schematic arrangement of Merz-Price protection scheme for a star connected alternator.

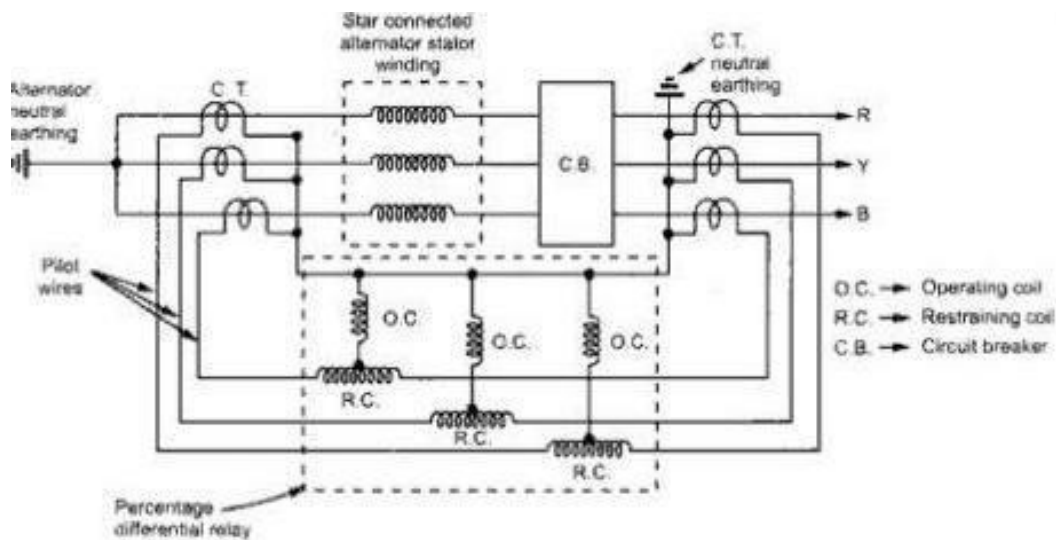

The differential relay gives protection against short circuit fault in the stator winding of a generator. When the neutral point of the windings is available then, the C.T.s may be connected in star on both the phase outgoing side and the neutral earth side, as shown in the above figure. But, if the neutral point is not available, then the phase side CTs are connected in a residual

connection, so that it can be made suitable for comparing the current with the generator ground point CT secondary current. The restraining coils are energized from the secondary connection of C.T.s in each phase, through pilot wires. The operating coils are energized by the tappings from restraining coils and the C.T. neutral earthing connection.

The similar arrangement is used for the delta connected alternator stator winding, as shown below.

This scheme provides very fast protection to the stator winding against phase to phase faults and phase to ground faults. If the neutral is not grounded or grounded through resistance then additional sensitive earth fault relay should be provided. The advantages of this scheme are, 1. Very high speed operation with operating time of about 15 msec. 2. It allows low fault setting which ensures maximum protection of machine windings. 3. It ensures complete stability under most severe through and external faults. 4. It does not require current transformers with air gaps or special balancing features.

Earth fault protection of Generators

The neutral point of the generator is usually earthed, so as to facilitate the protection of the stator winding and associated system. Impedance is inserted in the earthing lead to limit the magnitude of the earth fault current. Generators which are directly connected to the transmission or distribution system are usually earthed through a resistance which will pass approximately rated current to a terminal earth fault. In case of generator-transformer unit, the generator winding and primary winding of a transformer can be treated as an isolated system that is not influenced by the earthing requirements of the transmission system. Modern practice is to use a large earthing transformer (5-100 KVA) – the secondary winding which is designed for 100-500V is loaded with a resistor of a value, which when referred through the transformer ratio, will pass a suitable fault current. The resistor is therefore of low value and can be of rugged construction. It is important that the earthing transformer never becomes saturated, otherwise a very undesirable condition of ferro resonance may occur.

Earth fault protection can be obtained by applying a relay to measure the transformer secondary current by connecting a voltage measuring relay in parallel with the load resistor

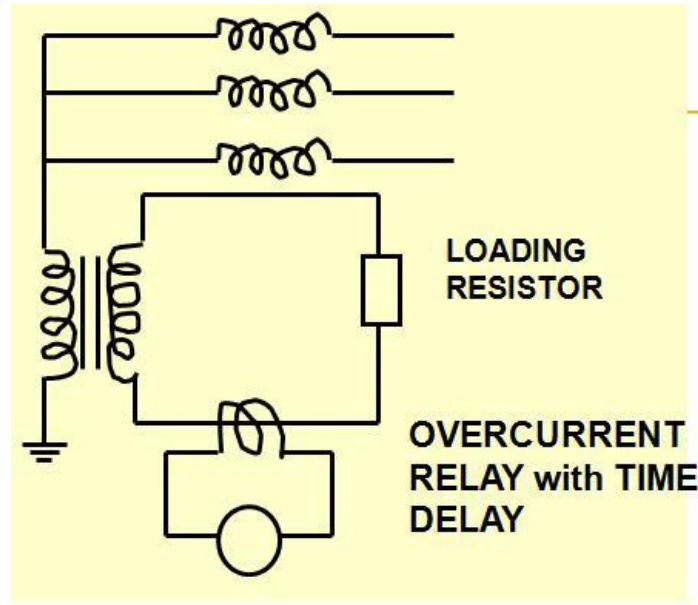

Generator and Transformer Unit Biased Differential Protection

In a high voltage transmission system, the bus bars are at very high voltages than the generators. The generators are directly connected to step up transformer to which it is connected, together from a generator transformer unit. The protection of such a unit is achieved by differential protection scheme using circulating current principle. While providing protection to such a unit, it is necessary to consider the phase shift and current transformation in the step up transformer. The figure in the following page, shows a biased differential protection scheme used for generator transformer unit. The zone of such a scheme includes the stator windings, the step up transformer and the intervening connections. The transformer is delta-star hence the current transformers on high voltage side are delta connected while those on generator side are star connected. This cancels the displacement between line currents introduced by the delta connected primary of the transformer. Where there is no fault, the secondary currents of the current transformer connected on generator side are equal to the currents in the pilot wires from the secondaries of the delta connected current transformers on the secondary of main transformer. When a fault occurs, the pilot wires carry the differential current to operate the percentage differential relay.

For the protection against the earth faults, an earth fault relays is put in the secondary winding of the main step up transformers as shown. In such a case, differential protection acts as a backup protection to the restricted earth fault protection. This overall differential protection scheme does not include unit transformer as a separate differential scheme is provided it.

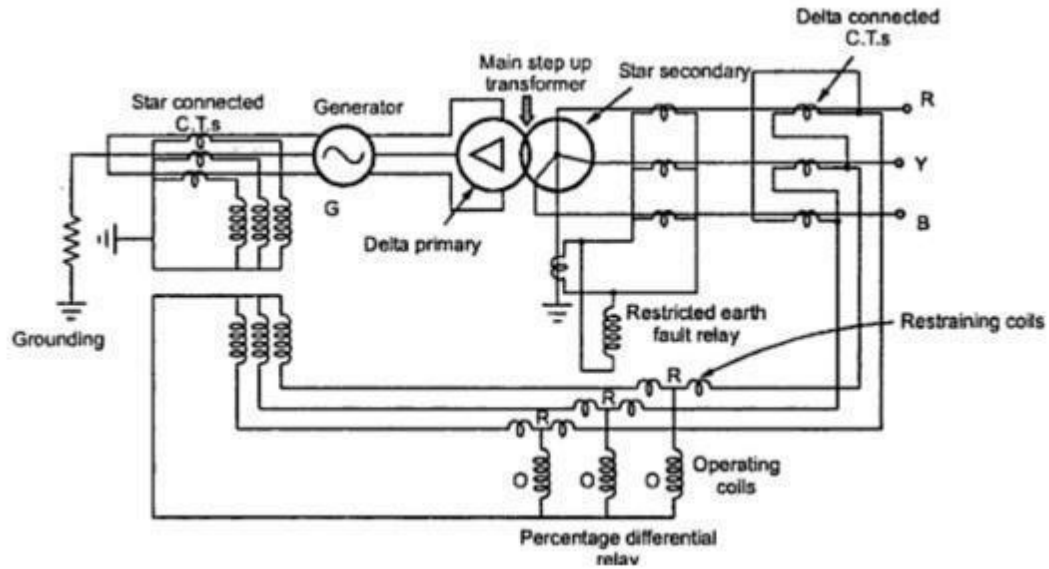

PHASE FAULT

- Phase-phase faults clear of earth are less common. They may occur on the end portion of stator coils or in the slots if the winding involves two coil sides in the same slot. In the later case the fault will involve earth in a very short time.
- Phase fault current is not controlled by the method of earthing the neutral point.

INTERTURN FAULTS

- Interturn faults are also uncommon, but not unknown
- A greatest danger arising from failure to deal with interturn faults quickly is fire. A large portion of the insulation is inflammable

Negative sequence protection

The negative sequence component can be detected by the use of a filter network. Many negative sequence filter circuits have been evolved. One typical negative sequence filter circuit is as follows

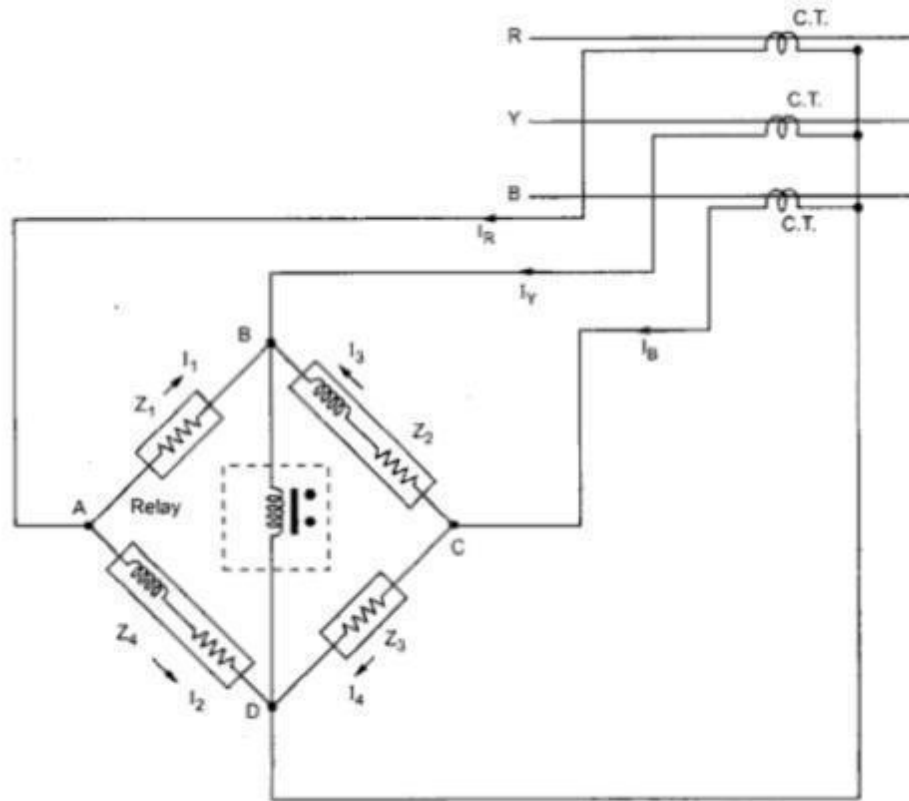

Basically it consists of a resistance bridge network as depicted in the first figure showing the circuit connection. The magnitudes of the impedances of all the branches of the network are equal. The impedances Z_1 and Z_3 are purely resistive while the impedances Z_2 and Z_4 are the combinations of resistance and reactance. The currents in the branches Z_2 and Z_4 lag by 60° from the currents in the branches Z_1 and Z_3 . The vertical branch B-D basically consists of an over current element with inverse time characteristics having negligible impedance compared to the bridge impedances.

3.4 protection of bus bars

The protection scheme for a power system should cover the whole system against all probable types of faults. Unrestricted forms of line protection such as over current and distance systems, meet this requirement, although faults in the Bus bar zone are cleared only after some time delay. If unit protection is applied to feeder and plant the bus bars are not inherently protected. Bus bars have been left without specific protection. Different bus bar faults are as follows. BUSBAR FAULTS

- Majority of bus faults involve one phase and earth, but faults arise from many causes and a significant number are inter-phase clear of earth.
- With fully phase-segregated metal clad gear, only earth faults are possible, and a protective scheme need have earth fault sensitivity only.

- For outdoor busbars , protection schemes ability to respond to inter-phase faults clear of earth is an advantage

TYPES OF PROTECTION SCHEMES

- System protection used to cover bus bars
- Frame –earth protection
- Differential protection

SYSTEM PROTECTION

- A system protection that includes over current or distance systems will inherently give protection cover to the bus bars.
- Over current protection will only be applied to relatively simple distribution systems, or as a back-up protection set to give considerable time delay. Distance protection will provide cover with its second zone.
- In both cases, therefore ,the bus bar protection so obtained is slow

Frame-earth Protection

- This is purely an earth fault system, and in principle involves simply measuring the fault current flowing from the switchgear frame to earth. To this end a current transformer is

mounted on the earthing conductor and is used to energize a simple instantaneous relay.

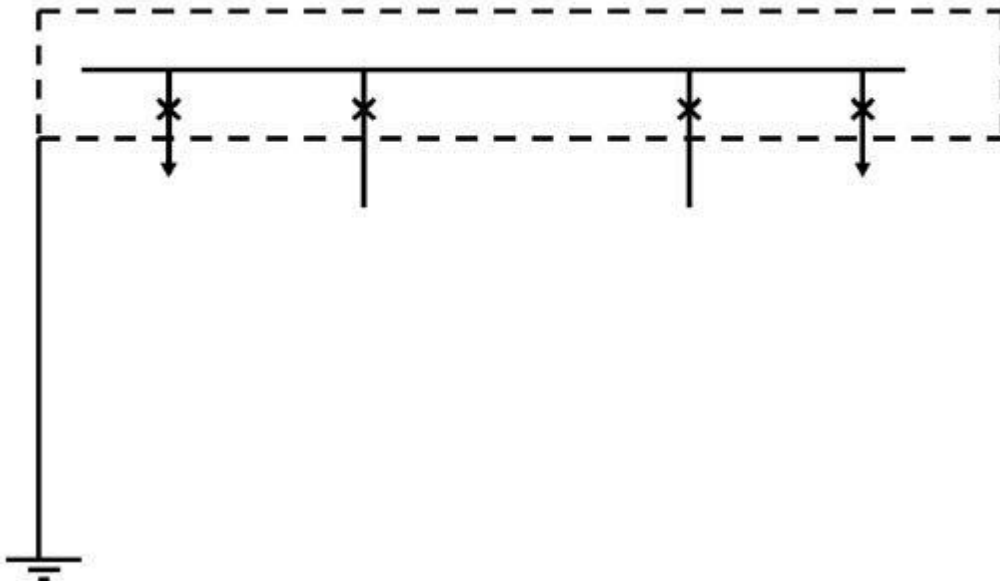

This protection is nothing but the method of providing earth fault protection to the bus bar assembly housed in a frame. This protection can be provided to the metal clad switchgear. The arrangement is shown in the figure below. The metal clad switchgear is lightly insulated from the earth. The enclosure of the frame housing different switchgears and bus bars is grounded through a primary of current transformer in between. The concrete foundation of switchgear and the other equipments are lightly insulated from the ground. The resistance of these equipments with earth is about 12 ohms. When there is an earth fault, then fault current leaks from the frame and passes through the earth connection provided. Thus the primary of C.T. senses the current due to which current passes through the sensitive earth fault relay, thereby operating the relay.

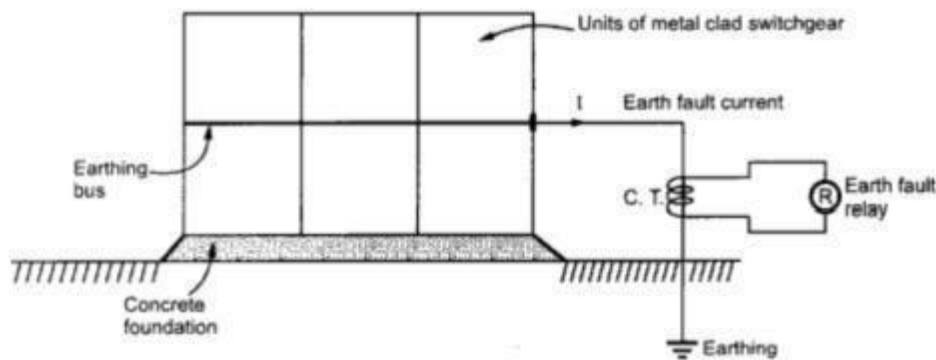

3.5 Zones and types of Protection system

Zones of Protection system

- An electric power system is divided into several zones of protection. Each zone of protection, contains one or more components of a power system in addition to two circuit breakers.
- When a fault occurs within the boundary of a particular zone, then the protection system responsible for the protection of the zone acts to isolate (by tripping the Circuit Breakers) every equipment within that zone from the rest of the system.
- The circuit Breakers are inserted between the component of the zone and the rest of the power system. Thus, the location of the circuit breaker helps to define the boundaries of the zones of protection.
- Different neighbouring zones of protection are made to overlap each other, which ensure that no part of the power system remains without protection. However, occurrence of the fault with in the overlapped region will initiate a tripping sequence of different circuit breakers so that the minimum necessary to disconnect the faulty element

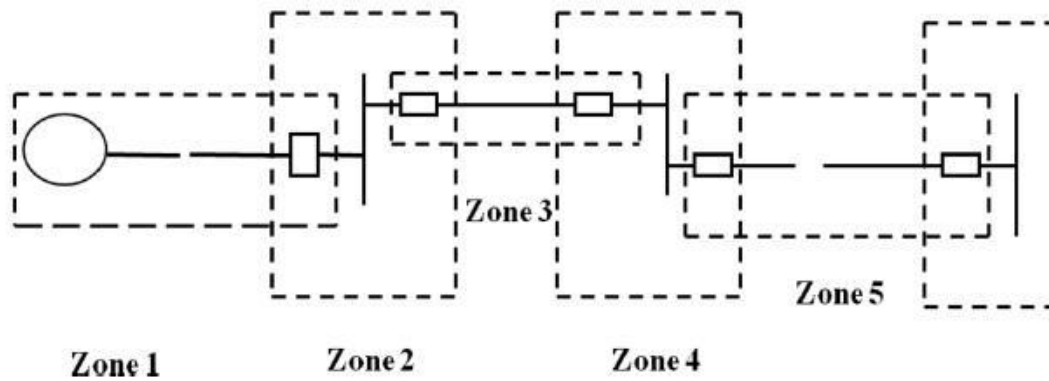

Types of Protection (Primary and Back-up Protection)

Primary Protection

The primary protection scheme ensures fast and selective clearing of any fault within the boundaries of the circuit element, that the zone is required to protect. Primary Protection as a rule is provided for each section of an electrical installation.

However, the primary protection may fail. The primary cause of failure of the Primary Protection system are enumerated below.

1. Current or voltage supply to the relay.
2. D.C. tripping voltage supply
3. Protective relays
4. Tripping circuit
5. Circuit Breaker

Back-up Protection

Back-up protection is the name given to a protection which backs the primary protection whenever the later fails in operation. The back-up protection by definition is slower than the primary protection system. The design of the back-up protection needs to be coordinated with the design of the primary protection and essentially it is the second line of defence after the primary protection system.

3.6 CTs and PTs and their applications in protection schemes.

Current transformers are generally used to measure currents of high magnitude. These transformers step down the current to be measured, so that it can be measured with a normal range ammeter. A Current transformer has only one or very few number of primary turns. The

primary winding may be just a conductor or a bus bar placed in a hollow core (as shown in the figure). The secondary winding has large number turns accurately wound for a specific turns ratio.

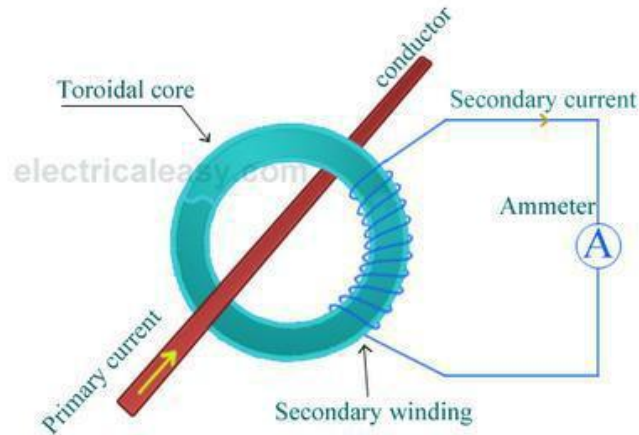

Thus the current transformer steps up (increases) the voltage while stepping down (lowering) the current. Now, the secondary current is measured with the help of an AC ammeter. The turns ratio of a transformer is $N_P / N_S = I_S / I_P$

- UPS systems
- Transfer switches
- Motor-generator sets
- Commercial sub-metering,
- CT 's in one package for 3-phase metering
- Accurate measuring for metering/WATT/VAR
- Current sensing, recording, monitoring & control
- Control panels and drives
- Standard CT used as measuring standard for comparison
- Winding temperature indicator (WTI) for power transformers
- Summation current transformers.

Potential Transformer (PT)

Potential transformers are also known as voltage transformers and they are basically step down transformers with extremely accurate turns ratio. Potential transformers step down the voltage of high magnitude to a lower voltage which can be measured with standard measuring instrument. These transformers have large number of primary turns and smaller number of secondary turns. A potential transformer is typically expressed in primary to secondary voltage ratio. For example, a 600:120 PT would mean the voltage across secondary is 120 volts when primary voltage is 600 volts.

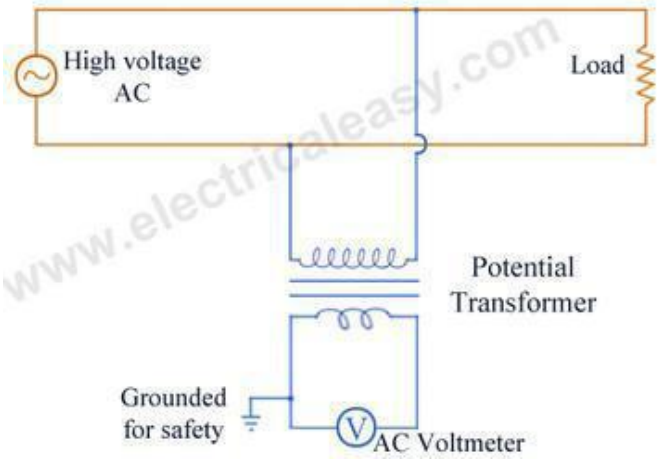

UNIT IV

THEORY OF CIRCUIT INTERRUPTION

4.1 Formation of arc during circuit breaking

The phenomena of Arc

During opening of current carrying contacts in a circuit breaker the medium in between opening contacts become highly ionized through which the interrupting current gets low resistive path and continues to flow through this path even after the contacts are physically separated. During the flowing of current from one contact to other the path becomes so heated that it glows in the form of an arc.

Arc in circuit breaker

Whenever, the contacts of circuit breaker open while carrying load there is an arc in the medium between the separating contacts of the circuit breaker. As long as this arc is sustained in between the contacts, the current through the circuit breaker will not be interrupted totally. For total interruption of current, the arc needs to be quenched as quickly as possible. The main designing criteria of a circuit breaker is to provide appropriate technology of arc quenching in circuit breaker to fulfill quick and safe current interruption. So before going through different arc quenching techniques employed in circuit breaker, it is first necessary to understand the phenomena of arc in circuit breaker.

Role of arc in circuit breaker

When two current carrying contacts open, an arc bridges the contact gap through which the current gets a low resistive path to flow so there will not be any sudden interruption of current. As there is no sudden and abrupt change in current during opening of the contacts, there will not be any abnormal switching over voltage in the system. Let i is the current flowing through the contacts just before they open and L is the system inductance, switching over voltage during opening of contacts, may be expressed as $V = L.(di/dt)$ where di/dt rate of change of current with respect to time during opening of the contacts. In the case of alternating current arc is momentarily extinguished at every current zero. After crossing every current zero the medium between separated contacts gets ionized again during next cycle of current and the arc in circuit breaker is reestablished. To make the interruption complete and successful, this re-ionization in between separated contacts to be prevented after a current zero.

If arc in circuit breaker is absence during opening of current carrying contacts, there would be sudden and abrupt interruption of current which will cause a huge switching overvoltage sufficient to severely stress the insulation of the system. On the other hand, the arc provides a gradual but quick, transition from the current carrying to the current breaking states of the contacts.

Arc Interruption or Arc Quenching or Arc Extinction Theory

At high temperature the charged particles in a gas move rapidly and randomly, but in absence of electric field, no net motion occurs. Whenever an electric field is applied in the gas, the charged particles gain drift velocity superimposed on their random thermal motion. The drift velocity is proportional to the voltage gradient of the field and particle mobility. The particle mobility depends upon the mass of the particle, heavier particles, lower the mobility. The mobility also depends upon mean free paths available in the gas for random movement of the particles. Since every time a particle collides, it loses its directed velocity and has to be re-accelerated in the direction of electric field again. Hence net mobility of the particles is reduced. If the medium has high pressure, it becomes denser and hence, the gas molecules come closer to each other, therefore collision occurs more frequently which lowers the mobility particles. The total current by charged particles is directly proportional to their mobility. Therefore the mobility of charged particles depends upon the temperature, pressure of the gas and as well as nature of the gas. Again the mobility of gas particles determines the degree ionization of gas.

So from above explanation we can say that ionization process of gas depends upon nature of gas (heavier or lighter gas particles), pressure of gas and temperature of gas. As we said earlier the intensity of arc column depend up on the presence of ionized media between separated electrical contacts, hence, special attention should be given in reducing ionization or increasing deionization of media between contacts. That is why the main designing feature of circuit breaker is to provide different pressure control methods, cooling methods for different arc media in between circuit breaker contacts.

HEAT LOSS FROM ARC

Heat loss from an arc in circuit breaker takes place through conduction, convection as well as radiation. In circuit breaker with plain break arc in oil, arc in chutes or narrow slots nearly all the heat loss due to conduction. In air blast circuit breaker or in breaker where a gas flow is present between the electrical contacts, the heat loss of arc plasma occurs due to convection process. At normal pressure the radiation is not a significant factor but at higher pressure the radiation may become a very important factor of heat dissipation from arc plasma. During opening of electrical contacts, the arc in circuit breaker is produced and it is extinguished at every zero crossing, getting established again during the next cycle. The final arc extinction or arc quenching in circuit breaker can be achieved by rapid increase of the dielectric strength in the medium between the contacts so that the arc gets quenched after the first zero crossing. This rapid increase of dielectric strength in between circuit breaker contacts is achieved either by deionization of gas in the arc media or by replacing ionized gas by cool and fresh gas. There are various deionization processes applied for arc extinction in circuit breaker, let us discussed in brief.

DEIONIZATION OF GAS DUE TO INCREASING PRESSURE

If pressure of the arc path increases, the density of the ionized gas is increased which means, the particles in the gas come closer to each other and as a result the mean free path of the particles is reduced. This increases the collision rate and as we discussed earlier at every collision the charged particles loss their directed velocity along electric field and again they are re-accelerated towards field. It can be said that over all mobility of the charged particles is reduced so the voltage required to maintain the arc is increased. Another effect of the increased density of particles is a higher rate of deionization of gas due to the recombination of oppositely charged particles.

The rate of ionization of gas depends upon the intensity of impact during collision of gas particles. The intensity of impact during collision of particles again depends upon velocity of random motions of the particles. This random motion of a particle and its velocity increases with increase of temperature of the gas. Hence it can be concluded like that if temperature of a gas is increased; its ionization process is increased and opposite statement is also true that is if the temperature is decreased the rate of ionization of gas is decreased means deionization of gas is increased. Therefore more voltage required to maintain arc plasma with a decreased temperature. Finally it can be said that the cooling effectively increases the resistance of the arc.

The insulating material (may be fluid or air) used in circuit breaker should serve two important functions as follows:

1. It should provide sufficient insulation between the contacts when circuit breaker opens.
2. It should extinguish the arc occurring between the contacts when circuit breaker opens.

Methods of arc interruption

There are two methods by which interruption is done.

1. High resistance method.
2. Low resistance method or zero interruption method.

In high interruption method we can increase the electrical resistance many times to such a high value that it forces the current to reach to zero and thus restricting the possibility of arc to be struck again. Proper steps must be taken in order to ensure that the rate at which the resistance is increased or decreased is not abnormal because it may lead to generation of harmful induced voltages in the system. The arc resistance can be increased by various methods like lengthening or cooling of the arc etc.

Limitations of high resistance method: Arc discharge has a resistive nature due to this most of the energy is received by circuit breaker itself hence proper care should be taken during the manufacturing of circuit breaker like mechanical strength etc. Therefore this method is applied in dc power circuit breaker, low and medium ac power circuit breaker.

Low resistance method is applicable only for ac circuit and it is possible there because of presence of natural zero of current. The arc gets extinguished at the natural zero of the ac wave and is prevented from restricting again by rapid building of dielectric strength of the contact space.

There are two theories which explains the phenomenon of arc extinction:

1. Energy balance theory,
2. Voltage race theory.

Before going in details about these theories, we should know the following terms.

Restriking voltage: It may be defined as the voltage that appears across the breaking contact at the instant of arc extinction.

Recovery voltage :

It may be defined as the voltage that appears across the breaker contact after the complete removal of transient oscillations and final extinction of arc has resulted in all the poles.

Active recovery voltage :

It may be defined as the instantaneous recovery voltage at the instant of arc extinction.

Arc voltage :

It may be defined as the voltage that appears across the contact during the arcing period, when the current flow is maintained in the form of an arc. It assumes low value except for the point at which the voltage rise rapidly to a peak value and current reaches to zero.

4.2 AC and DC circuit breaking

DC circuit breakers and AC breaker main difference is the ability to arc. Because the exchange of each cycle, have had zero, zero easy to extinction in the past, but has not been zero DC switching, arc extinguishing ability is poor, so to add additional interrupter device. DC arc is generally difficult, but the exchange has zero, breaking easily. Exchange can be derived for the DC circuit breaker protection, attention to three changes: 1, overload and short circuit protection.

1. long delay overload protection.

By thermal-action (double metal components) for long delay overload protection, the source of its action as I^2R , AC RMS and DC current equal to the average, there is no need to use any restructuring. However, the large current size, to the current transformer secondary current heat who can not be used due to transformer can not be used on DC circuits. Release long delay if the overload is the use of electromagnetic type (hydraulic type, that is, oil cup), then the delayed release characteristics to change, the minimum operating current to 110% -140% bigger,

so the whole electromagnetic Release not be used for DC circuits (such as the use will have to re-design).

2.short circuit protection.

Thermal - Magnetic AC circuit breaker short-circuit protection is the use of magnetic system, which is used by the filtering of the rectifier circuit (DC), need to exchange the original setting current value multiplied by a factor of

1.Electromagnetic type of short circuit protection and thermal dynamic electromagnetic same.

2.circuit breaker accessories, such as shunt release, under voltage release, electrically operated institutions; shunt, under voltage are voltage coil, as long as the line voltage, is used for systems, need not be Any change can be used for DC system. Auxiliary and alarm contacts, AC and DC common. Electric operating mechanism for the DC Time to re-design.

3. unlike the exchanges as DC current zero-crossing characteristics, dc short circuit current (or even multiple small fault current) is breaking; arc out all the difficulties, so wiring should be two extreme ways or three poles in series increase the fracture, so that the fracture energy to bear part of the arc.

- DC arcs are to be interrupted by increasing the resistance interruption method in which resistance of the arc is increased so that the arc voltage can no longer maintain the current and the arc is extinguished.
- Size of DC circuit breaker increases as the voltage level increases.
- AC arcs current reduces to zero in each cycle (2 times)
- If the circuit breaker contacts are opened at time when the current passed through zero and dielectric strength of the medium is build up rapidly so that arc cannot strike again then arc can be extinguished successfully.
- Size of AC circuit breaker can be small compared to same voltage DC circuit breaker.

4.3 Restriking voltage and recovery voltage

It is the transient voltage that appears across the contacts at or near current zero during arcing period.If dielectric strength rise is greater than the rise of restriking voltage then the arc will not restrike.

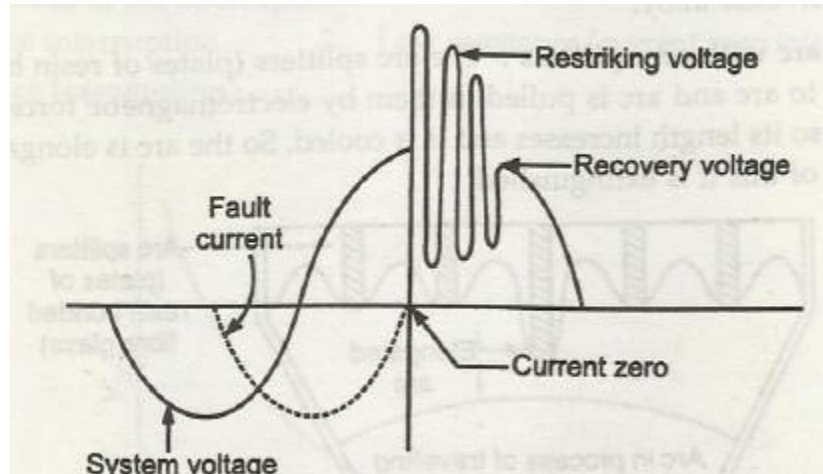

Restriking Voltage :

it is the transient voltage that exists during the arcing time. (natural frequency kHz).

Recovery Voltage :

it is the rms voltage after final arc extinction. (normal frequency 50 or 60 Hz).

both voltages appear between circuit breaker poles.

- A circuit breaker is a piece of equipment which can Make or break a circuit either manually or by remote control under normal conditions.
- Break a circuit automatically under fault condition
- Make a circuit either manually or by remote under fault condition
- Circuit Breaker consists of fixed and moving contacts called electrodes
- Under normal operating condition these contacts remain closed and will not open automatically unless the system becomes faulty .These contacts can be opened manually or by remote control.
- When a fault occurs in a circuit the trip coils of the circuit breaker get energized and the moving contacts are pulled apart by some mechanism ,thus opening the circuit.

4.4 Rate of rise of recovery voltage

It is the rate of increase of restriking voltage and is abbreviated by R.R.R.V. its unit is kV/m sec. Consider the fig2 below showing the opening of circuit breaker under fault conditions. Before current interruption, the capacitance C is short circuited by the fault and the short circuit current through the breaker is limited by inductance L of the system

The short circuit current will lag the voltage by 90° where i represents the short circuit current and ea represents the arc voltage. Under short circuit condition the entire generator voltage appears across inductance L . when the contacts are opened and the arc finally extinguishes at some current zero, the generator voltage e is suddenly applied to the inductance and capacitance in series. This L-C combination forms an oscillatory circuit produces a transient

of frequency; $f_n = 1 / [2\pi(LC)^{1/2}]$, which appears across the capacitor and hence across the contacts of the circuit breaker. This transient voltage is known as restriking voltage and may reach an instantaneous peak value twice the peak phase neutral voltage i.e. $2 E_m$.

It is R.R.R.V, which decides whether the arc will re-strike. If R.R.R.V is greater than the rate of rise of dielectric strength between the contacts, the arc will re-strike. The arc will fail to re-strike if R.R.R.V is less than the rate of increase of dielectric strength between the contacts of the breaker.

The value of R.R.R.V depends on:

- Recovery voltage
- Natural frequency of oscillations

4.5 Resistance switching

To reduce the restriking voltage, RRRV and severity of the transient oscillations, a resistance is connected across the contacts of the circuit breaker.

This is known as resistance switching. The resistance is in parallel with the arc. A part of the arc current flows through this resistance resulting in a decrease in the arc current and increase in the deionization of the arc path and resistance of the arc.

This process continues and the current through the shunt resistance increases and arc current decreases. Due to the decrease in the arc current, restriking voltage and RRRV are reduced. The resistance may be automatically switched in with the help of a sphere gap as shown in Fig. The resistance switching is of great help in switching out capacitive current or low inductive current.

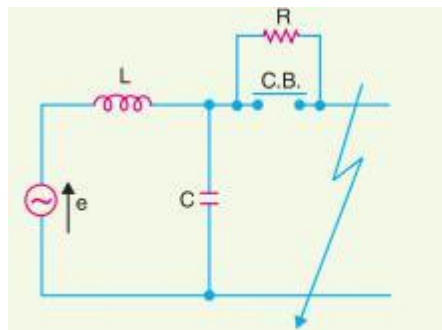

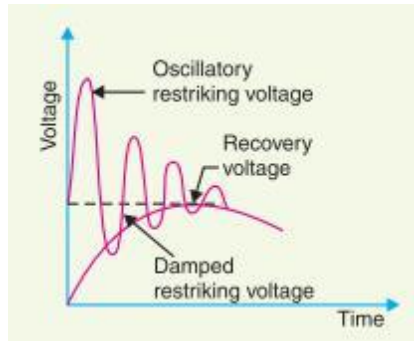

The analysis of resistance switching can be made to find out the critical value of the shunt resistance to obtain complete damping of transient oscillations. Figure 5.8 shows the equivalent electrical circuit for such an analysis.

Unipolar switching

Unipolar systems usually have a dielectric that is a simple TMO. Examples are NiO [12], CuO, CoO, Fe₂O₃, HfO, TiO₂Ta₂O₅, Nb₂O₅ [10,11]. These systems are good insulators with a large resistivity. They would normally not show any RS effect. To get the systems into the switching regime it is usually required to perform an initial ‘electroforming’ step. In this process, a strong electric field is applied, which brings the system close to the dielectric break down. A full break down is prevented by a current limitation or compliance. After this ‘SET’ procedure, the resistance of the device shows a significant decrease, reaching a ‘low resistance’ state, *RLO*, which is stable, i.e., non-volatile. This state has an ohmic *I-V* characteristic at low bias. To switch the system to the ‘high resistance’ state, *RHI*, a voltage has to be applied to the device, with either the same or opposite polarity than the previously applied ‘forming’ voltage. In this ‘RESET’ step, the resistance of the system suddenly increases, back to a ‘high resistance’ value close to the original one.

No current compliance should be used in the RESET step. In fact, the resistance change occurs when the current through the device becomes larger than the value of the compliance. To SET the system again in the low resistance state, a voltage with current compliance has to be once again applied, similarly to the forming step. The system’s resistance suddenly decreases down to a value close to *RLO* at a threshold voltage *V_{th}*, which is smaller than the forming one. The SET and RESET switching process can be repeated many times. The magnitude of resistance change typically remains within well-defined values, however some dispersion is often observed. An example of a typical electroforming and successive RESET and SET steps are shown in Fig

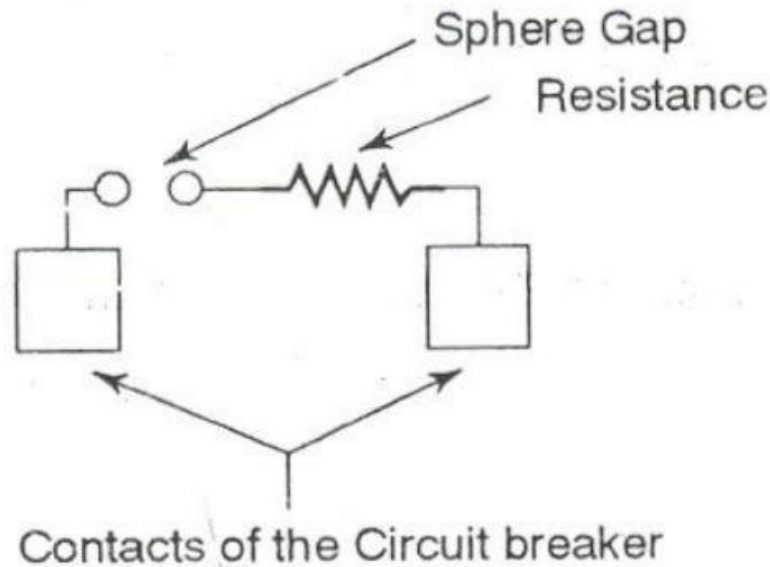

Bipolar switching

Bipolar resistive switching has been observed in a variety of ternary oxides with perovskite structure such as SrTiO_3 (STO), SrZrO_3 , and also in more complex systems such as the ‘colossal’ magnetoresistive manganites LSMO, LCMO, PCMO, PLCMO, and even in cuprate superconductors YBCO and BSCCO. Some reports indicate that better performance may be obtained by small chemical substitution, such as $\text{Bi}:\text{SrTiO}_3$ and $\text{Cr}:\text{SrTiO}_3$. These bipolar systems may be either insulators or poor metals. Strong hysteresis in the two-terminal resistance is often observed without the need of an initial forming step. Nevertheless, electro-forming is usually done, as it may improve the reproducibility of resistive switching, but this initial forming step remains not well understood [13].

The choice of a proper electrode material for each dielectric is an important issue for bipolar devices. Sawa and collaborators have performed a systematic study, concluding that a key feature for RS is the formation of Schottky barriers [10]. In fact, the observed scaling of RHI and RLO with the geometry of the devices indicate that the phenomenon should take place at the electrode/oxide interfaces.

4.6 current chopping

Current chopping is a term that came to our vocabulary with the advent of vacuum switching which was commercially started back in the 1950’s. Earlier switching means in air or oil are in terms of dielectric recovery rate relatively slow and as the main contacts would part the arc would go through several zero crossings before it would finally go out and the dielectric strength across the now open gap be strong to prevent a restrike, and thus continuation of current for a further half cycle. With the introduction of vacuum as a dielectric medium that has a completely different characteristic to that of air or oil dielectrics in so much that it has a very

rapid dielectric recovery rate. Upon opening the main contacts of a vacuum interrupter whether is be a circuit breaker or a contactor, high velocity movements are easily obtained because of the low mass and small movements required to obtain arc isolation up to limited high voltages. As such, the arc will be extinguished at the first current zero and within half a cycle. Because of the rapid recovery rate of the dielectric, the arc, in vacuum interrupter will tend to go out before current zero which will result in an instantaneous current drop to zero and lead to an induced voltage or voltage transient being generated to down-stream equipment.

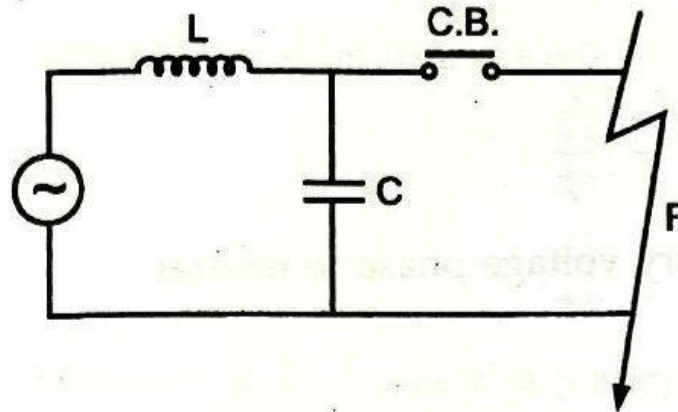

This can be seen by calculating the formula. $V_t = I_C \times Z_0$ V_t – Voltage Transient I_C – Current Chop Z_0 – Surge Impedance Therefore if the current chop is .9 of an amp and the surge impedance is 3,000 ohm's, the voltage transient will equal 2700 volts on top of the RMS system voltage whether it be 4160 or 5KV. However if the current chop is 5 amps times surge impedance of 3,000 ohms, then the voltage transient can equal 15KV on top of the RMS supply voltage. You will notice from the above that some assumptions are made with regards to surge impedance values which are difficult to obtain and vary per circuit. In addition, the voltage transient value that a motor or dry type transformer will withstand is difficult to obtain from motor and transformer manufacturers. Therefore Joslyn Clark has taken the approach in their designs by the contact material mix gives an interrupt characteristic more than capable of handling the maximum horsepower rating lock rotor currents in terms of interrupt level and keeping the chopping current to an absolute minimum.

Over the years this philosophy has proven itself as unlike other manufacturers we have yet to see motor insulation problems created by our contactor. The motors manufactured to NEMA design standards which we consider high class or on motors produced to IEC standards which we consider to be of a lower class, cheaper version.

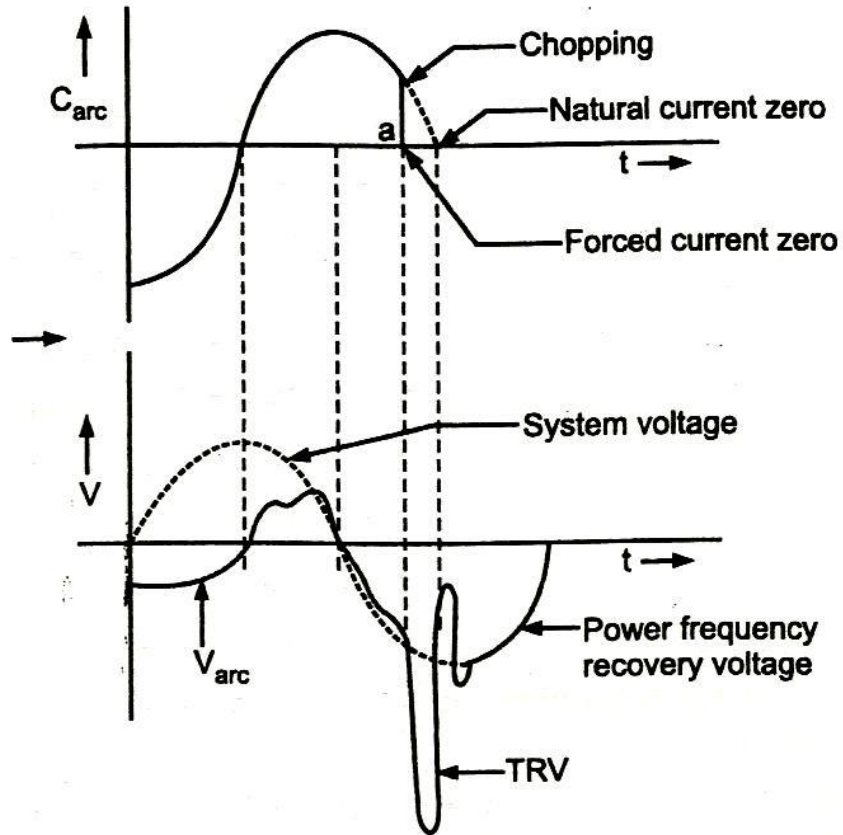

UNIT V

CIRCUIT BREAKERS

5.1 Rating of Circuit Breaker

The **rating of a circuit breaker** includes,

- 1) Rated short circuit breaking current.
- 2) Rated short circuit making current.
- 3) Rated operating sequence of circuit breaker.
- 4) Rated short time current.

Short circuit breaking current of circuit breaker

This is the maximum short circuit current which a circuit breaker can withstand before it. Finally cleared by opening its contacts. When a short circuit flows through a circuit breaker, there would be thermal and mechanical stresses in the current carrying parts of the breaker. If the contact area and cross-section of the conducting parts of the circuit breaker are not sufficiently large, there may be a chance of permanent damage in insulation as well as conducting parts of the CB. The short circuit current has a certain value at the instant of contact separation. The breaking current refers to value of current at the instant of the contact separation. The rated values of transient recovery voltage are specified for various rated voltage of circuit breakers. For specified conditions of rated TRV and rated power frequency recovery voltage, a circuit breaker has a certain limit of breaking current. This limit is determined by conducting short circuit type tests on the circuit breaker. The waveforms of short circuit current are obtained during the breaking test. The evaluation of the breaking current is explained in Fig. 3. The breaking current is expressed by two values. The r.m.s values of a.c. components are expressed in KA. the standard values being 8, 10, 12.5, 16, 20, 25, 31.5, 40, 45, 63, 80 and 100KA. The earlier practice was to express the rated breaking capacity of a circuit breaker in terms of MVA given as follows $\text{Rated Breaking MVA capacity} = \sqrt{3} \times \text{KV} \times \text{KA}$ Where MVA = Breaking capacity of a circuit breaker kV KV = Rated voltage KA = Rated breaking current.

This practice of specifying the breaking capacity in terms of MVA is convenient while calculating the fault levels. However, as per the revised standards, the breaking capacity is expressed in KA for specified conditions of TRV and this method takes into account both breaking current and TRV. The breaking capacity can be both symmetrical and asymmetrical in nature. In asymmetrical breaking capacity the DC component of the current is added. While selecting the circuit breaker for a particular location in the power system the fault level at that location is determined. The rated breaking current can then be selected from standard range.

Rated short circuit making capacity

The short circuit making capacity of circuit breaker is expressed in peak value not in rms value like breaking capacity. It may so happen that circuit breaker may close on an existing fault. In such cases the current increase to the maximum value at the peak of first current loop. The circuit breaker should be able to close without hesitation as contact touch. The circuit breaker should be able to withstand the high mechanical forces during such a closure. These capabilities are proved by carrying out making current test. The rated short circuit making current of a circuit breaker is the peak value of first current loop of short circuit current (I_{pk}) which the circuit breaker is capable of making at its rated voltage. The rated short circuit making current should be least 2.5 times the r.m.s. value of a.c. component of rated breaking current. Rated making current = $1.8 \times \sqrt{2} \times$ Rated short circuit breaking = $2.5 \times$ Rated short circuit breaking current. In the above equation the factor $\sqrt{2}$ convert the r.m.s value to peak value. Factor 1.8 takes into account the doubling effect of short circuit current with consideration to slight drop in current during the first quarter cycle.

Rated operating sequence or duty cycle of circuit breaker

This is mechanical duty requirement of circuit breaker operating mechanism. The sequence of rated operating duty of a circuit breaker has been specified as O – t – CO – t'' – CO. Where O indicates opening operation of the CB. CO represents closing operation immediately followed by an opening operation without any intentional time delay. t'' is time between two operations which is necessary to restore the initial conditions and / or to prevent undue heating of conducting parts of circuit breaker. t = 0.3 sec for circuit breaker intended for first auto re closing duty, if not otherwise specified. Suppose rated duty circle of a circuit breaker is O – 0.3 sec – CO – 3 min – CO. This means, an opening operation of circuit breaker is followed by a closing operation after a time interval of 0.3 sec, then the circuit breaker again opens without any intentional time delay. After this opening operation the CB is again closed after 3 minutes and then instantly trips without any intentional time delay.

Rated short time current

This is the current limit which a circuit breaker can carry safely for certain specific time without any damage.

The circuit breakers do not clear the short circuit current as soon as any fault occurs in the system. There always some intentional and an intentional time delays present between the instant of occurrence of fault and instant of clearing the fault by CB. This delay is present because of time of operation of protection relays, time of operation of circuit breaker and also there may be some intentional time delay imposed in relay for proper coordination of power system protection. Hence, after fault, a circuit breaker has to carry the short circuit for certain time. The summation of all time delays should not be more than 3 seconds, hence a circuit breaker should be capable of carrying a maximum fault current for at least this short period of time. The short circuit current may have two major affects inside a circuit breaker.

1. Because of the high electric current, there may be high thermal stress in the insulation and conducting parts of CB.

2. The high short circuit current, produces significant mechanical stresses in different current carrying parts of the circuit breaker.

A circuit breaker is designed to withstand these stresses. But no circuit breaker has to carry a short circuit current not more than a short period depending upon the coordination of protection. So it is sufficient to make CB capable of withstanding effects of short circuit current for a specified short period.

The rated short time current of a circuit breaker is at least equal to rated short circuit breaking current of the circuit breaker.

Rated voltage of circuit breaker

Rated voltage of circuit breaker depends upon its insulation system. For below 400 KV system, the circuit breaker is designed to withstand 10% above the normal system voltage. For above or equal 400 KV system the insulation of circuit breaker should be capable of withstanding 5% above the normal system voltage. That means, rated voltage of circuit breaker corresponds to the highest system voltage. This is because during no load or small load condition the voltage level of power system is allowed rise up to highest voltage rating of the system. A circuit breaker is also subject to two other high voltage condition.

1) Sudden disconnection of huge load for any other cause, the voltage imposed on the CB and also between the contacts when the CB is open, may be very high compared to higher system voltage. This voltage may be of power frequency but does not stay for very long period as this high voltage situation must be cleared by protective switchgear. But a circuit breaker may have to withstand this power frequency over voltage, during its normal life span.

The Circuit Breaker must be rated for power frequencies withstand voltage for a specific time only. Generally the time is 60 seconds. Making power frequency withstand capacity, more than 60 second is not economical and not practically desired as all the abnormal situations of electrical power system are definitely cleared within much smaller period than 60 seconds.

2) Like other apparatuses connected to power system, a circuit breaker may have also to face lightning impulse and switching impulses during its life span.

The insulation system of CB has to withstand these impulse voltage waveform. So a circuit breaker is designed to withstand this impulse peaky voltage for microsecond range only.

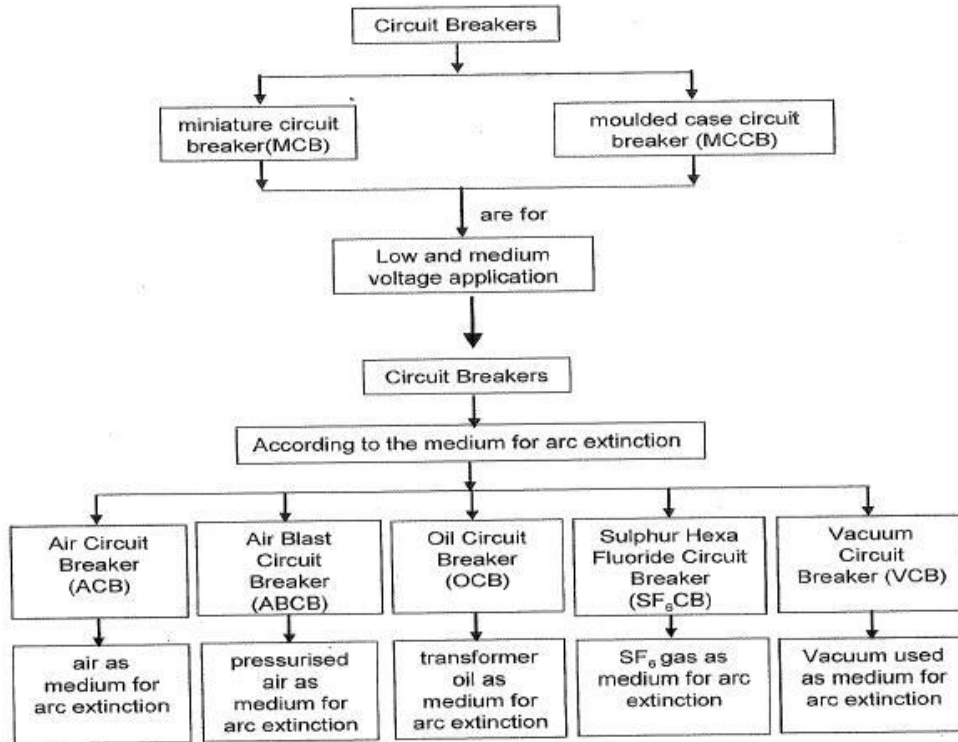

5.2 Air blast circuit breaker

This type of circuit breakers, is those kind of circuit breaker which operates in air at atmospheric pressure. After development of oil circuit breaker, the medium voltage air circuit breaker (ACB) is replaced completely by oil circuit breaker in different countries. But in countries like France and Italy, ACBs are still preferable choice up to voltage 15 KV. It is also good choice to avoid the risk of oil fire, in case of oil circuit breaker. In America ACBs were exclusively used for the system up to 15 KV until the development of new vacuum and SF6 circuit breakers.

Working principle of air circuit breaker(ACB)

The working principle of this breaker is rather different from those in any other types of circuit breakers. The main aim of all kind of circuit breaker is to prevent the reestablishment of arcing after current zero by creating a situation where in the contact gap will withstand the system recovery voltage. The air circuit breaker does the same but in different manner. For interrupting arc it creates an arc voltage in excess of the supply voltage. Arc voltage is defined as the minimum voltage required maintaining the arc. This circuit breaker increases the arc voltage by mainly three different ways,

1. It may increase the arc voltage by cooling the arc plasma. As the temperature of arc plasma is decreased, the mobility of the particle in arc plasma is reduced, hence more voltage gradient is required to maintain the arc.

1. Main contacts 4. Arcsplitterplates
2. Arcing contacts 5. Current carrying terminals
3. Arc rifling in the direction of the arrow 6. Arc runners Arc getting split

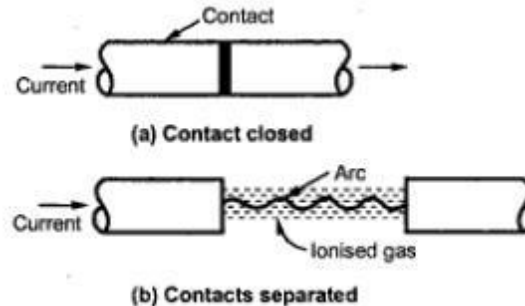

In the air reservoir there is a high pressure air stored between 20 to 30 kg/cm². And that air is taken from compressed air system. On the reservoir there are three hollow insulator columns mounted with valves at their base. On the top of the hollow insulator chambers there are double arc extinguishing chambers mounted. The current carrying parts connect the three arc extinction chambers to each other in series and the pole to the neighboring equipment, since there exist a very high voltage between the conductor and the air reservoir, the entire arc extinction chamber assembly is mounted on insulators. Since there are three double arc extinction poles in series, there are six breakers per pole. Each arc extinction chamber consists of one twin fixed contact. There are two moving contacts. The moving contacts can move axially so as to open or close. Its opening or closing mechanism depends on spring pressure and air pressure.

The operation mechanism operates the rods when it gets a pneumatic or electrical signal. The valves open so as to send the high pressure air in the hollow of the insulator. The high pressure air rapidly enters the double arc extinction chamber. As the air enters into the arc extinction chamber the pressure on the moving contacts becomes more than spring pressure and it causes the contacts to be open.

The contacts travel through a short distance against the spring pressure. At the end of contacts travel the part for outgoing air is closed by the moving contacts and the entire arc extinction chamber is filled with high pressure air, as the air is not allowed to go out. However, during the arcing period the air goes out through the openings and takes away the ionized air. While closing, the valve is turned so as to close connection between the hollow of the insulator and the reservoir.

The valve lets the air from the hollow insulator to the atmosphere. As a result the pressure of air in the arc extinction chamber is dropped down to the atmospheric pressure and the moving contacts close over the fixed contacts by virtue of the spring pressure, the opening is fast because the air takes a negligible time to travel from the reservoir to the moving contact. The arc is extinguished within a cycle. Therefore, air blast circuit breaker is very fast in breaking the

current. Closing is also fast because the pressure in the arc extinction chamber drops immediately as the valve operates and the contacts close by virtue of the spring pressure.

Advantages:

- How air blast circuit breaker is better than oil circuit breaker:
- The growth of dielectric strength is so rapid that final contact gap needed for arc extinction is very small, this reduces the size of device.
- The risk of fire is eliminated.
- Due to lesser arc energy, air blast circuit breakers are very suitable for conditions where frequent operation is required.
- The arcing products are completely removed by the blast whereas the oil deteriorates with successive operations; the expense of regular oil replacement is avoided.
- The energy supplied for arc extinction is obtained from high pressure air and is independent of the current to be interrupted.
- The arcing time is very small due to the rapid buildup of dielectric strength between contacts. Therefore, the arc energy is only a fraction that in oil circuit breakers, thus resulting in less burning of contacts.

Disadvantages:

- Considerable maintenance is required for the compressor plant which supplies the air blast.
- Air blast circuit breakers are very sensitive to the variations in the rate of restriking voltage.
- Air blast circuit breakers are finding wide applications in high voltage installations. Majority of circuit breakers for voltages beyond 110 kV are of this type.

5.3 Oil circuit breakers

Types Of Oil Circuit Breakers

Oil circuit breakers can be classified into following types:

1) Bulk oil circuit breakers

which use a large quantity of oil. In this circuit breaker the oil serves two purposes. Firstly it extinguishes the arc during opening of contacts and secondly it insulates the current conducting parts from one another and from the earthed tank. Such circuit breakers are classified into:

- Plain oil circuit breakers
- Arc control circuit breakers

In the former type no means is available for controlling the arc and the contacts are exposed to the whole of the oil in the tank. In the latter special arc control devices are employed to get the beneficial action of the arc as efficiently as possible

2) Low oil circuit breakers,

which use minimum amount of oil. In such circuit breakers oil is used only for arc extinction, the current conducting parts are insulated by air or porcelain or organic insulating material.

Construction

There are two chambers in a low oil circuit breaker; the oil in each chamber is separated from each other. The main advantage of this is that low oil is required and oil in second chamber won't get polluted. Upper chamber is called the circuit breaker chamber and lower one is called the supporting chamber. Circuit breaking chamber consists of moving contact and fixed contact. Moving contact is connected with a piston it's just for the movement of the contact and no pressure build due to its motion. There are two vents on fixed contact they are axial vent for small current produced in oil due to heating of arc and radial vents for large currents. The whole device is covered using Bakelite paper and porcelain for protection. Vents are placed in a tabulator.

Operation

Under normal operating conditions, the moving contacts remain engaged with the upper fixed contact. When a fault occurs, the moving contact is pulled down by the tripping springs and an arc is struck. The arc vaporizes oil and produces gases under high pressure. This action constrains the oil to pass through a central hole in the moving contact and results in forcing series of oil through the respective passages of the turbulator. The process of tabulation is orderly one, in which the sections of arc are successively quenched by the effect of separate streams of oil, moving across each section in turn and bearing away its gases

constrains the oil to pass through a central hole in the moving contact and results in forcing series of oil through the respective passages of the turbulator. The process of tabulation is orderly one, in which the sections of arc are successively quenched by the effect of separate streams of oil, moving across each section in turn and bearing away its gases

Advantages

A low oil circuit breaker has following advantages compared to bulk oil circuit breaker

- It requires lesser quantity of oil
- It requires smaller space
- There is reduced risk of fire
- Maintenance problems are reduced

Disadvantages

- Low oil circuit breaker has following disadvantages compared to bulk oil circuit breaker
- Due to smaller quantity of oil, the degree of carbonization is increased
- There is a difficulty of removing the gases from the contact space in time
- The dielectric strength of oil deteriorates rapidly due to high degree of carbonization.

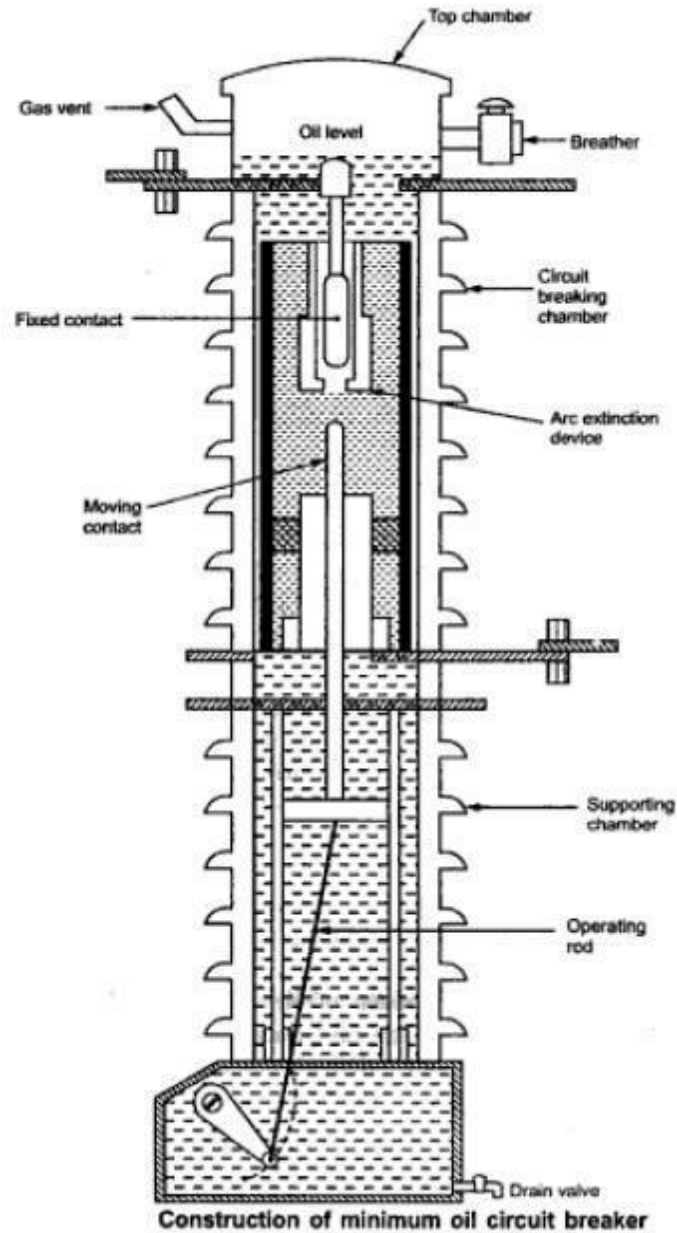

5.4 SF6 circuit breaker.

At this point we are aware that the medium in which arc extinction of the circuit breaker takes place greatly influences the important characteristics and life of the circuit breaker. The working of a vacuum circuit breaker was illustrated. We already know that the use of vacuum circuit breaker is mainly restricted to system voltage below 38 kV. The characteristics of vacuum as medium and cost of the vacuum CB does not makes it suitable for voltage exceeding 38 kV. In the past for higher transmission voltage Oil Circuit Breaker (OCB) and Air Blast Circuit Breaker (ABCB) were used. These days for higher transmission voltage levels SF6 Circuit Breakers are largely used. OCB and ABCB have almost become obsolete. In fact in many installations SF6 CB is used for lower voltages like 11 kV, 6 kV etc.. Sulphur Hexafluoride symbolically written as SF6 is a gas which satisfy the requirements of an ideal arc interrupting medium. So SF6 is extensively used these days as an arc interrupting medium in circuit breakers ranging from 3 kv upto 765 kv class. In addition to this SF6 is used in many electrical equipments for insulation. Here first we discuss in brief, some of the essential properties of SF6 which is the reason of it's extensive use in circuit breakers

SF6 gas has high dielectric strength which is the most important quality of a material for use in electrical equipments and in particular for breaker it is one of the most desired properties. Moreover it has high Rate of Rise of dielectric strength after arc extinction.

This characteristics is very much sought for a circuit breaker to avoid restriking.

- SF6 is colour less, odour less and non toxic gas.
- SF6 is an inert gas. So in normal operating condition the metallic parts in contact with the gas are not corroded. This ensures the life of the breaker and reduces the need for maintenance.
- SF6 has high thermal conductivity which means the heat dissipation capacity is more. This implies greater current carrying capacity when surrounded by SF6 .
- The gas is quite stable. However it disintegrates to other fluorides of Sulphur in the presence of arc. but after the extinction of the arc the SF6 gas is reformed from the decomposition.
- SF6 being non-flammable so there is no risk of fire hazard and explosion.

A sulfur hexafluoride circuit breaker uses contacts surrounded by sulfur hexafluoride gas to quench the arc. They are most often used for transmission-level voltages and may be incorporated into compact gas-insulated switchgear. In cold climates, supplemental heating or de-rating of the circuit breakers may be required due to liquefaction of the SF6 gas.

Advantages:

- Due to superior arc quenching property of sf6 , such breakers have very short arcing time

- Dielectric strength of sf6 gas is 2 to 3 times that of air, such breakers can interrupt much larger currents.
- Gives noiseless operation due to its closed gas circuit
- Closed gas enclosure keeps the interior dry so that there is no moisture problem
- There is no risk of fire as sf6 is non-inflammable
- There are no carbon deposits
- Low maintenance cost, light foundation requirements and minimum auxiliary equipment
- sf6 breakers are totally enclosed and sealed from atmosphere, they are particularly suitable where explosion hazard exists

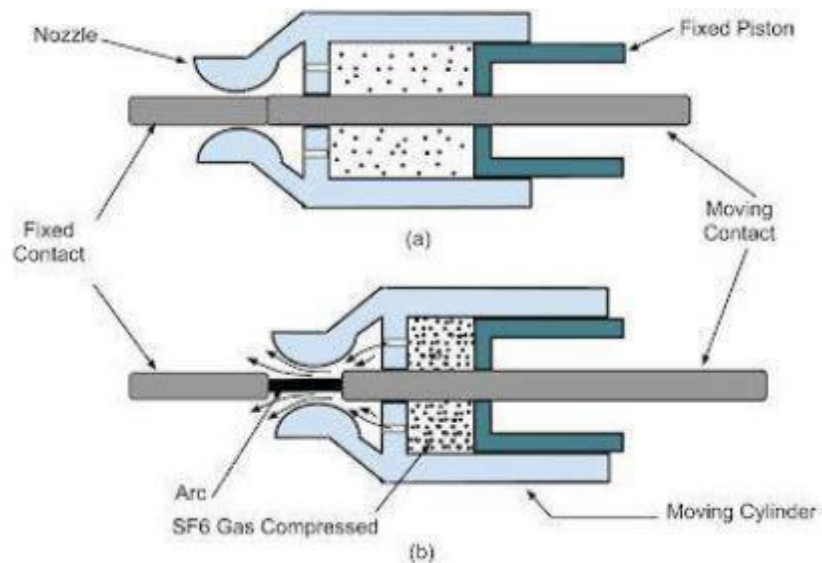

Disadvantages:

- sf6 breakers are costly due to high cost of sf6
- sf6 gas has to be reconditioned after every operation of the breaker, additional equipment is required for this purpose

CONSTRUCTION, PRINCIPLE OF OPERATION

The construction and working principles of SF6 circuit breaker varies from manufacturer to manufacturer. In the past double pressure type of SF6 breakers were used. Now these are obsolete. Another type of SF6 breaker design is the self blast type, which is usually used for medium transmission voltage. The Puffer type SF6 breakers of single pressure type are the most favored types prevalent in power industry. Here the working principle of Puffer type breaker is illustrated (Fig-A)

As illustrated in the figure the breaker has a cylinder and piston arrangement. Here the piston is fixed but the cylinder is movable. The cylinder is tied to the moving contact so that for opening the breaker the cylinder along with the moving contact moves away from the fixed contact (Fig-A(b)). But due to the presence of fixed piston the SF₆ gas inside the cylinder is compressed. The compressed SF₆ gas flows through the nozzle and over the electric arc in axial direction. Due to heat convection and radiation the arc radius reduces gradually and the arc is finally extinguished at current zero.

The dielectric strength of the medium between the separated contacts increases rapidly and restored quickly as fresh SF₆ gas fills the space. While arc quenching, small quantity of SF₆ gas is broken down to some other fluorides of sulphur which mostly recombine to form SF₆ again. A filter is also suitably placed in the interrupter to absorb the remaining decomposed byproduct.

The gas pressure inside the cylinder is maintained at around 5 kgf per sq. cm. At higher pressure the dielectric strength of the gas increases. But at higher pressure the SF₆ gas liquify at higher temperature which is undesired. So heater is required to be arranged for automatic control of the temperature for circuit breakers where higher pressure is utilised. If the SF₆ gas will liquify then it loses the ability to quench the arc. Like vacuum breaker, SF₆ breakers are also available in modular design form so that two modules connected in series can be used for higher voltage levels. SF₆ breakers are available as both live tank and dead tank types. In Fig-B above a live tank outdoor type 400 kV SF₆ breaker is shown.

5.5 vacuum circuit breakers

In this breaker, vacuum is being used as the arc quenching medium. Vacuum offers highest insulating strength, it has far superior arc quenching properties than any other medium. When contacts of a breaker are opened in vacuum, the interruption occurs at first current zero with dielectric strength between the contacts building up at a rate thousands of times that obtained with other circuit breakers. **Principle:** When the contacts of the breaker are opened in vacuum (10^{-7} to 10^{-5} torr), an arc is produced between the contacts by the ionization of metal vapours of contacts. The arc is quickly extinguished because the metallic vapours, electrons, and ions produced during arc condense quickly on the surfaces of the circuit breaker contacts, resulting in quick recovery of dielectric strength. As soon as the arc is produced in vacuum, it is quickly extinguished due to the fast rate of recovery of dielectric strength in vacuum

Construction:

Fig shows the parts of a typical vacuum circuit breaker. It consists of fixed contact, moving contact and arc shield mounted inside a vacuum chamber. The movable member is connected to the control mechanism by stainless steel bellows. This enables the permanent sealing of the vacuum chamber so as to eliminate the possibility of leak. A glass vessel or ceramic vessel is used as the outer insulating body. The arc shield prevents the deterioration of

the internal dielectric strength by preventing metallic vapours falling on the inside surface of the outer insulating cover.

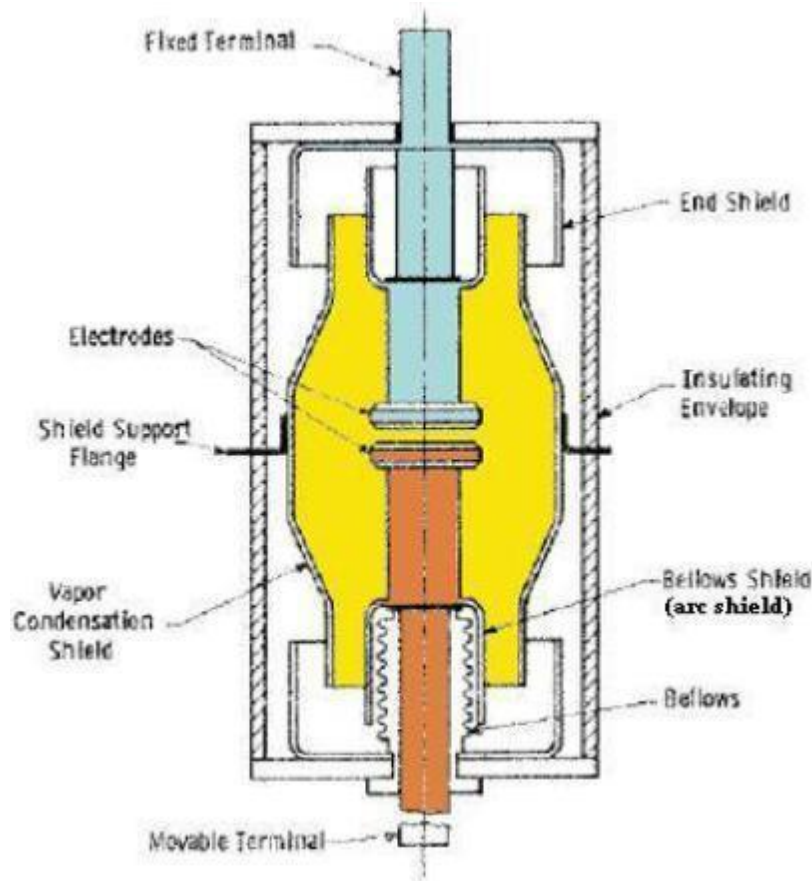

Working:

When the breaker operates the moving contacts separate from the fixed contacts and an arc is struck between the contacts. The production of arc is due to the ionization of metal ions and depends very much upon the material of contacts. The arc is quickly extinguished because the metallic vapours, electrons and ions produced during arc are diffused in short time and seized by the surfaces of moving and fixed members and shields. Since vacuum has very fast rate of recovery of dielectric strength, the arc extinction in a vacuum breaker occurs with a short contact separation.

Advantages:

- They are compact, reliable and have longer life.
- There are no fire hazards
- There is no generation of gas during and after operation
- They can interrupt any fault current. The outstanding feature of a VCB is that it can break any heavy fault current perfectly just before the contacts reach the definite open position.
- They require little maintenance and are quiet in operation

- Can withstand lightning surges
- Low arc energy
- Low inertia and hence require smaller power for control mechanism.

Applications:

- For outdoor applications ranging from 22 kV to 66 kV. Suitable for majority of applications in rural area.

5.6 testing of circuit breakers**Primary injection test**

For primary injection testing, high current is injected on the primary side of the current transformer. The entire chain – current transformer, conductors, connection points, relay protection and sometimes circuit breakers as well is covered by the test. The system being tested must be taken out of service during primary injection testing. Testing is usually conducted in connection with commissioning. The only way to verify that a direct-acting low voltage circuit breaker operates properly is to inject a high current.

Motion

A high-voltage breaker is designed to interrupt short-circuit current in a controlled manner. This puts great demands on the mechanical performance of all components in the interrupter chamber as well as the operating mechanism. It has to operate at a specific speed in order to build up adequate pressure to allow for cooling stream of air, oil or gas (depending on the type of breaker) to extinguish the arc that is generated after the contact separation until the next zerocrossing. It is important to interrupt the current to prevent a re-strike. This is accomplished by making sure that the contacts move apart far enough from each other before the moving contact has entered the so-called damping zone. The distance throughout which the breaker's electric arc must be extinguished is usually called the arcing zone. From the motion curve, a velocity or acceleration curve can be calculated in order to reveal even marginal changes that may have taken place in the breaker mechanics. The contact travel motion is captured by connecting a travel transducer on the moving part of the operating mechanism. The transducer provides an analogue voltage relative to the movement of the contact. The motion is presented as a curve where distance vs. time allows for further analysis. From the motion curve, a velocity or acceleration curve can be calculated in order to reveal changes in the breaker mechanics that may affect the breakers operation.

Travel

The travel trace indicates the instantaneous position of the circuit breaker contacts during an operation. This gives important information such as total travel, overtravel, rebound, undertravel, contact wipe or penetration of moving contact or operating-rod position at the time of close or open, and anomalies which are evident from the trace.

Speed

Speed is calculated between two points on this motion curve. The upper point is defined as a distance in length, degrees or percentage of movement from a) the breaker's closed or open position, or b) the contact-closure or contact- separation point. The time that elapses between these two points ranges from 10 to 20 ms, which corresponds to 1-2 zero-crossovers. The lower point is determined based on the upper point. It can either be a distance below the upper point or a time before the upper point. The single most important benefit derived from the instantaneous velocity and acceleration curves is the insight that they provide into the forces involved during the operation of a circuit breaker.

Acceleration

Average acceleration can be calculated from the velocity trace.

Damping

Damping is an important parameter to monitor and test as the stored energy an operating mechanism use to open and close a circuit breaker is considerable. The powerful mechanical stress can easily damage the breaker and/or reduce the breaker's useful life. The damping of opening operations is usually measured as a second speed, but it can also be based on the time that elapses between two points just above the breaker's open position.

EE 2402 — PROTECTION AND

SWITCHGEAR Question bank

UNIT 1

INTRODUCTION

PART A

1. What is surge absorber? How do they differ from surge diverter?
2. What is meant by insulation co-ordination?
3. Define the terms a) pick up value b) Reset value
3. What is time setting and plug setting multiplier ?
4. What are the causes of over voltages?
5. Define the term arcing ground
6. How the transmission lines are protected against direct lightning strokes?
7. What is a Peterson Coil?
8. List the merits and demerits of solid grounding
9. Defined the term switch gear
10. What type relay is best suited for long distance very high voltage transmission lines?
11. Define selectivity of protective relaying
12. Mention the different sources of over voltages in power system
13. List the basic requirements of lightning arrester
14. What are the demerits of a resistance grounded system?
15. Defined Breaker time
16. What are the causes over voltages on power system?
17. What is meant by voltage surge?
18. What is ground wire?
19. What is a protector tube?
20. Define basic impulse level.
21. A relay is connected to 400/5 ratio current transformer with current setting of 150%. Calculate the Plug Setting Multiplier when circuit carries a fault current of 4000 A
21. List the common protective scheme which are used for modern power system protection
22. What is the need for calculation short circuit current
23. What is the need for power system earthing
24. What is the need for protection
25. What are the protective zone of the power system

26. List at least two merits of resistance grounded system
27. How is arcing around avoided

PART B

1. Describe the essential qualities of a protective relaying
2. Briefly explain the various methods of overvoltage protection of Overhead transmission line
3. With a neat block diagram, explain the operating principle of Peterson coil
4. Discuss the symmetrical components methods to analyze an unbalanced system
5. Write short note on surge absorber
6. Discuss the basic ideas of insulation coordination in the practical power System
7. Discuss and compare the various methods of neutral earthing
8. What do you understand by a zone of protection? Discuss various types of Zones of protection.
9. Describe types of lightning arrester
10. What are the requirements of a ground wire for protecting power conductors against direct lightning stroke? Explain how they are achieved in practice

UNIT II

OPERATING PRINCIPLES AND RELAY CHARACTERISTICS

PART A

1. List the basic requirements of protective relay
2. What are the merits of mho relay?
3. Write the applications of attracted armature type electromagnetic relay
4. What are the different types of electromagnetic relays?
5. What is an under frequency relay?
6. What are the uses of Buchholz's relay?
7. What is meant by drop off / pick up ratio?
8. What is the need of relay coordination?
9. What are the different inverse time characteristics of over current relays? Mention how characteristics can be achieved in practice for an electromagnetic relay.
10. What are the advantages of static relays?
11. Write the applications of distance relay.
12. What type relay is best suited for long distance very high voltage

transmission lines?

13. What is meant by relay operating time?
14. Write the function of earth fault relay
15. List out the applications of static relays
16. Compare Static and Electromagnetic relay
17. What are the advantages of over current relays over electromagnetic types?
18. Define the term pilot with reference to power line protection.
19. What are the features of directional relay?
20. State the advantages, disadvantage and applications of electromagnetic relays
21. Give the block diagram for a basic static distance relay scheme
22. Draw the characteristics of a directional impedance relay and mho relay on an R-X diagram
23. What are the function of protective relay
24. What is relay
25. What is meant by biasing of relay
26. What is meant by time setting multiplier in protective relay
27. A relay is connected to 400/5 ratio current transformer with current setting of 150%. Calculate the Plug Setting Multiplier when circuit carries a fault current of 4000A.

PART B

1. Describe the construction and operation of an electromagnetic inductive relay with neat diagrams
- 2 Explain the principle of distance relays stating clearly the difference between impedance relay, reactance and mho relay. Indicate the difference on R-X diagrams and show where each type is suitable.
- 3 Describe the construction and operation of an electromagnetic relay with neat diagram
4. Describe the construction and principle of operation of an induction type directional over current relay Also explain its operational characteristics
5. Explain with the help of neat diagrams the construction and working of induction type directional power relay & non-directional over current relay
6. i) What is a static relay? What are the merits and demerits of static relays over electromagnetic relays also mention its applications. (8)
ii) Explain with the help of neat sketch the working principle and operation of attracted armature type electromagnetic relay (8)
7. Describe the operating principle, constructional features and area of applications of directional relay. How do you implement directional feature in the over current relay?

8. Explain MHO relay characteristic on the R-X diagram. Discuss the range setting of various distances
relays placed on a particular location
9. Write short notes on the following
- (a) Under frequency relays (8)
 - (b) Negative sequence relays (8)
10. i) A 3-Phase 11KV,25000KVA alternator with $X_{go}=0.05$ p.u , $X_1=0.15$ p.u & $X_2=0.15$ p.u is grounded through a reactance of 0.3 ohms .calculate the Line current for a single line to ground fault (8)
- ii) Write about the classifications of relays. (8)

UNIT III

APPARATUS PROTECTION

PART A

1. Define the term pilot with reference to power line protection
2. Give the limitations of Merz Price protection?
3. List out the applications of Buchholz's relay.
4. What are the causes of over speed and how alternators are protected from it?
5. What are the problems arising in differential protection in power transformer and how are they overcome?
6. Define the term burden on CT.
7. What is meant by time graded protection?
8. Explain the secondary of the current transformer should not be open.
9. What is R-X diagram?
10. Write the function of earth fault relay.
11. What is over fluxing protection of a transformer?
12. What is current grading of relays?
13. What is the most severe fault in the transmission line?
14. Write the effects of loss of excitation.
15. Classify the various bus bar faults
16. Why the secondary of C.T should not be open
17. Classify the various bus bar faults
18. List the common faults that occur in a generator
19. Which type of relays are used to protect transmission line

20. What are the faults which will occur in an alternator
21. Which type of relay is used to protect transmission line
22. What are the common methods used for line protection
23. Mention the different between CT used for protection and measurement
24. What are the problems associated with bus zone differential protection
25. What are the main safety device available with transformer

PART B

1. Explain with the help of neat sketch the working principle and operation of under frequency relay
2. Explain with a neat diagram the application of Merz price circulating current principle for the protection of the alternator.
3. Describe the construction and working of Buchholz relay
4. A star connected 3-phase, 20MVA, 11KV Alternator has a per phase reactance of 0.75 ohms/phase .It is protected by Merz price circulating current principle which is to operate for fault currents not less than 175A. Calculate the value of earthing resistance to be provided in order to ensure only 10% of the alternator winding remains unprotected.
5. Explain the features that cause difficulty in applying Merz-Price Circulating current principle to a power transformers
6. A three phase of 220/11000 line volts is connected in star/delta. The protective transformers on 220V side have a current ratio of 600/5. What should be the current transformer ratio on 11000V side.
7. Describe the differential pilot wire method of protection of feeder.
8. Describe the types of protective schemes employed for the protection of field winding and loss excitation of alternator.
9. With aid of neat schematic diagram, describe the percentage differential protection scheme of a transformer.
10. Explain the principle of percentage biased differential protection with necessary diagrams. Also discuss its applications
11. Explain Mho relay characteristics on R-X diagram. Discuss the range settings of various distance relays placed on a particular location.
12. Explain with the help of neat sketch, the working principle and operation of negative sequence relay.
13. A 10 MVA, 6.6 kV, 3 phase star connected alternator is protected by Merz-Price circulating current system. If the ratio of the current transformers is 1000/5, the minimum operating current for the relay is 0.75 A and the neutral point earthing resistance is 6 Ω . Calculate
14. i) The percentage of each of the stator windings which is unprotected against earth faults when the machine is operating at normal voltage. (8)

- ii) The minimum resistance to provide protection for 90% of the stator winding. (8)
15. Explain in detail, operation of measuring CT and protection CT with distinctive sketch
16. A 3 phase transformer having line voltage ratio of 440 V / 11 kV is connected in star – delta. The protection transformer on the LV side has a ratio of 500 / 5. What must be the ratio of the protection transformer connected on HV side?

UNIT IV

THEORY OF CIRCUIT INTERRUPTION

PART A

1. List the factors affecting the transient recovery voltage.
2. Define the term “rate of rise of recovery voltage”.
3. Give the difference between isolator and circuit breaker.
4. Mention the methods of arc interruption.
5. Differentiate a.c. and d.c. circuit circuit breaking
6. Discuss the arc phenomenon in a circuit breaker.
7. What are the basic requirements of a circuit breaker?
8. What are the disadvantages of an Air blast circuit breaker?
9. What is meant by recovery voltage?
10. What is resistance switching?
11. What do you meant by current chopping?
12. What is the importance of arc resistance? On which factor does it depend?
13. State the different methods of arc extinction
14. Define restriking voltage
15. What are the problems encountered in the interruption of capacitive currents
16. What are the methods used in quenching the arc circuit breaker
17. List the factors on which the arc resistance depends
18. Distinguish between recovery voltage and restriking voltage
19. What is the principle involved in High resistance interruption

PART B

1. Discuss the recovery rate theory and energy balance theory of arc interruption scheme of a transformer.
2. Explain the phenomenon of current chopping in a circuit breaker. What is the effect of current Chopping on the circuit breaker as well as on the system?
3. Derive an expression for Restriking voltage and rate of rise of restriking voltage in terms of system Voltage, inductance up to the fault location and bushings to earth capacitance of the circuit breaker.
4. i) Write short note on resistance switching.(8)
ii) Describe the operating principle of DC circuit breaker.(8)
5. (i) Calculate the RRRV of 132 kV circuit breaker with neutral earthed circuit breaker data as :
broken current is symmetrical, restriking voltage has frequency of 20 kHz, power factor is 0.15.
Assume fault is also earthed.(8)
(ii)Discuss the selection of circuit breakers for different ranges of system voltages (8)
6. State the principle of arc extinction. What are the methods of arc extinction? Describe them in detail.

UNIT V

CIRCUIT BREAKERS

PART A

1. What are the ratings of a circuit breaker?
2. What are the quenching factors in an Oil circuit breaker?
3. What is meant by making capacity of a circuit breaker?
4. How do you classify the circuit breakers.
5. Suggest a suitable choice of circuit breakers for the following voltage ranges:
(a) 3.3kV to 33kV, (b) 400kV to 760kV.
6. What is Peterson coil? What protective functions are performed by this device?
7. Give the advantage of SF6 circuit breaker over Air blast circuit breaker.
8. A three-phase oil circuit breaker is rated at 1500 A, 1000MVA and 33kV Find (a) rated symmetrical breaking current, (b) making capacity.
9. What are the disadvantages of an Air blast circuit breaker?
10. What are the basic requirements of a circuit breaker?
11. Write the operational difference between fuse and circuit breakers?
12. Enumerate the breaking capacity of circuit breaker.
13. How do you classify circuit breaker.

14. List the factors affecting the Transient Recovery voltage.
15. What are the significance of reliability tests on circuit breaker
16. What are the advantages of SF6 breakers
17. List the routine tests that are carried out on circuit breaker
18. What are the advantages of oil circuit breaker
19. What are the application of air blast circuit breaker
20. What are the disadvantage the plain break oil circuit breaker
21. Classify different types of circuit breaking.

PART B

1. With a neat diagram, discuss the constructional details and operational features of a typical minimum oil circuit breaker. Also state its advantages and disadvantages over others.
2. Explain the properties of vacuum, arc phenomenon, constructional details, working principle, merits and applications of vacuum circuit breakers.
3. Explain in detail the constructional features, principle of working, advantages and applications of SF₆ circuit breaker with a neat diagram.
4. Briefly describe the testing of circuit breakers
5. (i) A 50 Hz, 3 phase alternator has rated voltage 12 kV, connected to circuit breaker, inductive reactance 5 ohms/phase, C= 3μF. Determine maximum RRRv, peak restriking voltage and frequency of oscillations. (8)
(ii) Discuss the selection of circuit breakers for different ranges of system voltages (8)
6. With a neat block diagram, explain the construction, operating principles and merits of air blast circuit breaker.
7. Write brief note on
 - (i) Vacuum circuit breaker (8)
 - (ii) Testing of circuit breaker. (8)
8. Discuss how breaking capacity and making capacity of a circuit breaker are tested in a laboratory type testing stations.