

DESIGN OF ELECTRICAL APPARATUS

By

Mr. J.RAJESH

ASSISTANT PROFESSOR

DEPARTMENT OF ELECTRICAL AND ELECTRONICS ENGINEERING

PRATHYUSHA ENGINEERING COLLEGE

DESIGN OF ELECTRICAL APPARATUS

OBJECTIVES:

To provide sound knowledge about constructional details and design of various electrical machines.

- i. To study mmf calculation and thermal rating of various types of electrical machines.
- ii. To design armature and field systems for D.C. machines.
- iii. To design core, yoke, windings and cooling systems of transformers.
- iv. To design stator and rotor of induction machines.
- v. To design stator and rotor of synchronous machines and study their thermal behavior.

UNIT I INTRODUCTION 9

Major considerations in Electrical Machine Design - Electrical Engineering Materials – Space factor – Choice of Specific Electrical and Magnetic loadings - Thermal considerations - Heat flow – Temperature rise - Rating of machines – Standard specifications.

UNIT II DC MACHINES 9

Output Equations – Main Dimensions - Magnetic circuit calculations – Carter's Coefficient – Net length of Iron – Real & Apparent flux densities – Selection of number of poles – Design of Armature – Design of commutator and brushes – performance prediction using design values.

UNIT III TRANSFORMERS 9

Output Equations – Main Dimensions - KVA output for single and three phase transformers – Window space factor – Overall dimensions – Operating characteristics – Regulation – No load current – Temperature rise in Transformers – Design of Tank - Methods of cooling of Transformers.

UNIT IV INDUCTION MOTORS 9

Output equation of Induction motor – Main dimensions – Length of air gap- Rules for selecting rotor slots of squirrel cage machines – Design of rotor bars & slots – Design of end rings – Design of wound rotor -Magnetic leakage calculations – Leakage reactance of polyphase machines- Magnetizing current - Short circuit current – Circle diagram - Operating characteristics.

UNIT V SYNCHRONOUS MACHINES 9

Output equations – choice of loadings – Design of salient pole machines – Short circuit ratio – shape of pole face – Armature design – Armature parameters – Estimation of air gap length – Design of rotor –Design of damper winding – Determination of full load field mmf – Design of field winding – Design of turbo alternators – Rotor design.

TOTAL : 45 PERIODS

TEXT BOOKS

Sawhney, A.K., 'A Course in Electrical Machine Design', DhanpatRai& Sons, New Delhi, 1984.
Sen, S.K., 'Principles of Electrical Machine Designs with Computer Programmes', Oxford and IBH Publishing Co. Pvt. Ltd., New Delhi, 1987.

REFERENCES

A.Shanmugasundaram, G.Gangadharan, R.Palani 'Electrical Machine Design Data Book', New Age Intenational Pvt. Ltd., Reprint 2007.

EE8002 SLNO	DESIGN OF ELECTRICAL APPARATUS CONTENTS	PAGE NO
	Abbreviations and Symbols	7
UNIT I INTRODUCTION		15
1.1).	Major considerations in Electrical Machine Design	15
1.2).	Electrical Engineering Materials	16
1.3).	Space factor	21
1.4).	Choice of Specific Electrical and Magnetic loadings	21
1.5).	Thermal considerations	24
1.6).	Heat flow	25
1.7).	Temperature rise	25
1.8).	Rating of machines	26
1.9).	Standard specifications.	26
	QUESTION BANK	27-30
UNIT II DC MACHINES		33
2.1).	Introduction	33
2.2).	Output Equations	34
2.3).	Main Dimensions	36
2.4).	Magnetic circuit calculations	39
2.5).	Carter's Coefficient	40
2.6).	Net length of Iron	40
2.7).	Real & Apparent flux densities	41
2.8).	Selection of number of poles	44
2.9).	Design of Armature	46
2.10)	Design of commutator and brushes	50
2.11)	Performance prediction using design values.	51
	QUESTION BANK	53-57
UNIT III TRANSFORMERS		58
3.1).	Design features of power and distribution type transformers	58
3.2).	Output Equations	58
3.3).	Main Dimensions	61
3.4).	KVA output for single and three phase transformers	63
3.5).	Window space factor	63

	DESIGN OF ELECTRICAL APPARATUS	
EE8002		
3.6).	Overall dimensions	64
3.7).	Operating characteristics	64
3.8).	Regulation	64
3.9).	No load current	64
3.10).	Temperature rise in Transformers	65
3.11).	Design of Tank	68
3.12).	Methods of cooling of Transformers.	68
	QUESTION BANK	69-74
UNIT IV INDUCTION MOTORS		75
4.1).	Output equation of Induction motor	75
4.2).	Main dimensions	79
4.3).	Length of air gap	80
4.4).	Rules for selecting rotor slots of squirrel cage machines	80
4.5).	Design of rotor bars & slots	80
4.6).	Design of end rings	81
4.7).	Design of wound rotor	86
4.8).	Magnetic leakage calculations	89
4.9).	Leakage reactance of polyphase machines	89
4.10).	Magnetizing current	89
4.11).	Short circuit current	91
4.12).	Circle diagram	91
4.13).	Operating characteristics.	91
	QUESTION BANK	92-96
UNIT V SYNCHRONOUS MACHINES		97
5.1).	Introduction	97
5.2).	Relative dimensions of Turbo and water wheel alternators:	102
5.3).	Specifications of the synchronous machine:	103
5.4).	Main Dimensions:	103
5.5).	Output equations	103
5.6).	Choice of Specific loadings:	104
5.7).	Design of salient pole machines	106
5.8).	Short circuit ratio	106

EE8002		DESIGN OF ELECTRICAL APPARATUS	
	5.9).	Length of the air gap:	109
	5.10).	shape of pole face	109
	5.11).	Armature design	110
	5.12).	Armature parameters	111
	5.13).	Estimation of air gap length	111
	5.14).	Design of rotor	111
	5.15).	Design of damper winding	112
	5.16).	Determination of full load field MMF	112
	5.17).	Design of field winding	112
		QUESTION BANK	121-126
		SOLVED PROBLEMS	127
		MODEL QUESTION PAPERS	137

Abbreviations and Symbols:

<i>A</i>	linear current density [A/m]
<i>A</i>	magnetic vector potential [V s/m]
<i>A</i>	temperature class 105 °C
AC	alternating current
AM	asynchronous machine
A1–A2	armature winding of a DC machine
<i>a</i>	number of parallel paths in windings without commutator: per phase, in windings with a commutator: per half armature, diffusivity
<i>B</i>	magnetic flux density, vector [V s/m ²], [T]
<i>B_r</i>	remanence flux density [T]
<i>B_{sat}</i>	saturation flux density [T]
<i>B</i>	temperature class 130 °C
B1–B2	commutating pole winding of a DC machine
<i>b</i>	width [m]
<i>b_{0c}</i>	conductor width [m]
<i>b_c</i>	conductor width [m]
<i>b_d</i>	tooth width [m]
<i>b_{dr}</i>	rotor tooth width [m]
<i>b_{ds}</i>	stator tooth width [m]
<i>b_r</i>	rotor slot width [m]
<i>b_s</i>	stator slot width [m]
<i>b_v</i>	width of ventilation duct [m]
<i>b₀</i>	slot opening [m]
<i>C</i>	capacitance [F], machine constant, integration constant
<i>C</i>	temperature class > 180 °C
C1–C2	compensating winding of a DC machine
<i>C_f</i>	friction coefficient
<i>c</i>	specific heat capacity [J/kg K], capacitance per unit of length, factor, divider, constant
<i>c_p</i>	specific heat capacity of air at constant pressure
<i>c_{th}</i>	heat capacity
CTI	Comparative Tracking Index
<i>c_v</i>	specific volumetric heat [kJ/K m ³]
<i>D</i>	electric flux density [C/m ²], diameter [m]
DC	direct current

D_r	outer diameter of the rotor [m]
D_{ri}	inner diameter of the rotor [m]
D_s	inner diameter of the stator [m]
D_{se}	outer diameter of the stator [m]
D1–D2	series magnetizing winding of a DC machine
d	thickness [m]
d_t	thickness of the fringe of a pole shoe [m]
E	electromotive force (emf) [V], RMS, electric field strength [V/m], scalar, elastic modulus, Young's modulus [Pa]
E_a	activation energy [J]
\mathbf{E}	electric field strength, vector [V/m]
E	temperature class 120 °C
E	irradiation
E1–E2	shunt winding of a DC machine
e	electromotive force [V], instantaneous value $e(t)$
e	Napier's constant
F	force [N], scalar
\mathbf{F}	force [N], vector
F	temperature class 155 °C
FEA	finite element analysis
F_g	geometrical factor
F_m	magnetomotive force $\oint \mathbf{H} \cdot d\mathbf{l}$ [A], (mmf)
F1–F2	separate magnetizing winding of a DC machine or a synchronous machine
f	frequency [Hz], Moody friction factor
g	coefficient, constant, thermal conductance per unit length
G	electrical conductance
G_{th}	thermal conductance
H	magnetic field strength [A/m]
H_c, H_{cB}	coercivity related to flux density [A/m]
H_{cJ}	coercivity related to magnetization [A/m]
H	temperature class 180 °C, hydrogen
h	height [m]
h_{0c}	conductor height [m]
h_c	conductor height [m]
h_d	tooth height [m]
h_p	height of a subconductor [m]
h_{p2}	height of pole body [m]
h_s	stator slot height [m]
h_{yr}	height of rotor yoke [m]
h_{ys}	height of stator yoke [m]
I	electric current [A], RMS, brush current, second moment of an area, moment of inertia of an area [m ⁴]
IM	induction motor

I_u	current of the lower bar, slot current, slot current amount [A]
IC	classes of electrical machines
IEC	International Electrotechnical Commission
Im	imaginary part
i	current [A], instantaneous value $i(t)$
J	moment of inertia [kg m ²], current density [A/m ²], magnetic polarization
J	Jacobian matrix
J_{ext}	moment of inertia of load [kg m ²]
J_M	moment of inertia of the motor, [kgm ²]
J_{sat}	saturation of polarization [V s/m ²]
J_s	surface current, vector [A/m]
j	difference of the numbers of slots per pole and phase in different layers
j	imaginary unit
K	transformation ratio, constant, number of commutator segments
K_L	inductance ratio
k	connecting factor (coupling factor), correction coefficient, safety factor, ordinal of layers
k_C	Carter factor
$k_{\text{Cu}}, k_{\text{Fe}}$	space factor for copper, space factor for iron
k_d	distribution factor
k_E	machine-related constant
$k_{\text{Fe}\cdot n}$	correction factor
k_k	short-circuit ratio
k_L	skin effect factor for the inductance
k_p	pitch factor
k_{pw}	pitch factor due to coil side shift
k_R	skin effect factor for the resistance
k_{sat}	saturation factor
k_{sq}	skewing factor
k_{th}	coefficient of heat transfer [W/m ² K]
k_v	pitch factor of the coil side shift in a slot
k_w	winding factor
k_σ	safety factor in the yield
L	self-inductance [H]
L	characteristic length, characteristic surface, tube length [m]
LC	inductor–capacitor
L_d	tooth tip leakage inductance [H]
L_k	short-circuit inductance [H]
L_m	magnetizing inductance [H]
L_{md}	magnetizing inductance of an m -phase synchronous machine, in d-axis [H]
L_{mn}	mutual inductance [H]
L_{pd}	main inductance of a single phase [H]

l	length [m], closed line, distance, inductance per unit of length, relative inductance, gap spacing between the electrodes
\hat{l}	unit vector collinear to the integration path
l'	effective core length [m]
l_{ew}	average conductor length of winding overhang [m]
l_p	wetted perimeter of tube [m]
l_{pu}	inductance as a per unit value
l_w	length of coil ends [m]
M	mutual inductance [H], magnetization [A/m]
M_{sat}	saturation magnetization [A/m]
m	number of phases, mass [kg],
m_0	constant
N	number of turns in a winding, number of turns in series
N_{fl}	number of coil turns in series in a single pole
Nu	Nusselt number
N_{u1}	number of bars of a coil side in the slot
N_k	number of turns of compensating winding
N_p	number of turns of one pole pair
N_v	number of conductors in each side
N	Nondrive end
\mathbf{N}	set of integers
\mathbf{N}_{even}	set of even integers
\mathbf{N}_{odd}	set of odd integers
\mathbf{n}	normal unit vector of the surface
n	rotation speed (rotation frequency) [1/s], ordinal of the harmonic (sub), ordinal of the critical rotation speed, integer, exponent
n_U	number of section of flux tube in sequence
n_v	number of ventilation ducts
n_Φ	number of flux tube
P	power, losses [W]
P_{in}	input power [W]
PAM	pole amplitude modulation
PMSM	permanent magnet synchronous machine (or motor)
PWM	pulse width modulation
P_1, P_{ad}, P	additional loss [W]
Pr	Prandtl number
P_ρ	friction loss [W]
p	number of pole pairs, ordinal, losses per core length
p_{Al}	aluminium content
p^*	number of pole pairs of a base winding
pd	partial discharge
Q	electric charge [C], number of slots, reactive power [VA],
Q_{av}	average number of slots of a coil group
Q_o	number of slots of a coil group
Q'	number of radii in a voltage phasor graph
Q^*	number of slots of a base winding

Q_{th}	quantity of heat
q	number of slots per pole and phase, instantaneous charge, $q(t)$ [C]
q_k	number of slots in a single zone
q_m	mass flow [kg/s]
q_{th}	density of the heat flow [W/m^2]
R	resistance [Ω], gas constant, 8.314 472 [J/K mol], thermal resistance, reactive parts
R_{bar}	bar resistance [Ω]
RM	reluctance machine
RMS	root mean square
R_m	reluctance [$A/V s = 1/H$]
R_{th}	thermal resistance [K/W]
Re	real part
Re	Reynolds number
Re_{crit}	critical Reynolds number
RR	Resin-rich (impregnation method)
r	radius [m], thermal resistance per unit length
\hat{r}	radius unit vector
S1–S8	duty types
S	apparent power [VA], cross-sectional area
SM	synchronous motor
SR	switched reluctance
SyRM	synchronous reluctance machine
S_c	cross-sectional area of conductor [m^2]
S_p	pole surface area [m^2]
S_r	rotor surface area facing the air gap [m^2]
S	Poynting's vector [W/m^2], unit vector of the surface
s	slip, skewing measured as an arc length
T	torque [N m], absolute temperature [K], period [s]
Ta	Taylor number
Ta_m	modified Taylor number
T_b	pull-out torque, peak torque [N m]
t_c	commutation period [s]
TEFC	totally enclosed fan-cooled
T_J	mechanical time constant [s]
T_{mec}	mechanical torque [N m]
T_u	pull-up torque [N m]
T_v	counter torque [N m]
T_l	locked rotor torque, [N m]
t	time [s], number of phasors of a single radius, largest common divider, lifetime of insulation
τ	torque unit vector

U	depiction of a phase
U_m	magnetic voltage [A]
U_{sj}	peak value of the impulse voltage [V]
U_v	coil voltage [V]
U1	terminal of the head of the U phase of a machine
U2	terminal of the end of the U phase of a machine
u	voltage, instantaneous value $u(t)$ [V], number of coil sides in a layer
u_{bl}	blocking voltage of the oxide layer [V]
u_c	commutation voltage [V]
u_m	mean fluid velocity in tube [m/s]
V	volume [m ³], electric potential
V	depiction of a phase
V_m	scalar magnetic potential [A]
VPI	vacuum pressure impregnation
V1	terminal of the head of the V phase of a machine
V2	terminal of the end of the V phase of a machine
v	speed, velocity [m/s]
ν	vector
W	energy [J], coil span (width) [m]
W	depiction of a phase
W_d	energy returned through the diode to the voltage source in SR drives
W_{fc}	energy stored in the magnetic field in SR machines
W_{md}	energy converted to mechanical work while de-energizing the phase in SR drives
W_{mt}	energy converted into mechanical work when the transistor is conducting in SR drives
W_R	energy returning to the voltage source in SR drives
W'	coenergy [J]
W1	terminal of the head of the W phase of a machine
W2	terminal of the end of the W phase of a machine
W_ϕ	magnetic energy [J]
w	length [m], energy per volume unit
X	reactance [Ω]
x	coordinate, length, ordinal number, coil span decrease [m]
x_m	relative value of reactance
Y	admittance [S]
Y	temperature class 90 °C
y	coordinate, length, step of winding
y_m	winding step in an AC commutator winding
y_n	coil span in slot pitches
..	coil span of full pitch winding in slot pitches (slot pitch expressed in

Hy	hysteresis
i	internal, insulation
k	compensating, short circuit, ordinal
M	motor
m	mutual, main
mag	magnetizing, magnetic
max	maximum
mec	mechanical
min	minimum
mut	mutual
N	rated
n	nominal, normal
ns	negative-sequence component
o	starting, upper
opt	optimal
PM	permanent magnet
p	pole, primary, subconductor, pole leakage flux
p1	pole shoe
p2	pole body
ph	phasor, phase
ps	positive-sequence component
pu	per unit
q	quadrature, zone
r	rotor, remanence, relative
res	resultant
S	surface
s	stator
sat	saturation
sj	impulse wave
sq	skew
str	phase section
syn	synchronous
tan	tangential
test	test
th	thermal
tot	total
u	slot, lower, slot leakage flux, pull-up torque
v	zone, coil side shift in a slot, coil
...	...

γ	ordinal of a subconductor
ν	harmonic
ρ	ordinal number of single phasor
ρ	friction loss
ρ_w	windage (loss)
σ	flux leakage
Φ	flux

Subscripts

\wedge	peak/maximum value, amplitude
'	imaginary, apparent, reduced, virtual
*	base winding, complex conjugate
	Boldface symbols are used for vectors with components parallel to the unit vectors i, j and k
A	vector potential, $A = iA_x + jA_k + kA_z$
B	flux density, $B = iB_x + jB_k + kB_z$
\underline{I}	complex phasor of the current
\overline{I}	bar above the symbol denotes average value

UNIT 1

INTRODUCTION

Major considerations in Electrical Machine Design - Electrical Engineering Materials – Space factor – Choice of Specific Electrical and Magnetic loadings - Thermal considerations - Heat flow – Temperature rise - Rating of machines – Standard specifications.

1.1. Major considerations in Electrical Machine Design

The basic components of all electromagnetic apparatus are the field and armature windings supported by dielectric or insulation, cooling system and mechanical parts. Therefore, the factors for consideration in the design are,

Magnetic circuit or the flux path:

Should establish required amount of flux using minimum MMF. The core losses should be less.

Electric circuit or windings:

Should ensure required EMF is induced with no complexity in winding arrangement. The copper losses should be less.

Insulation:

Should ensure trouble free separation of machine parts operating at different potential and confine the current in the prescribed paths.

Cooling system or ventilation:

Should ensure that the machine operates at the specified temperature.

Machine parts:

Should be robust.

The art of successful design lies not only in resolving the conflict for space between iron, copper, insulation and coolant but also in optimization of cost of manufacturing, and operating and maintenance charges.

The factors, apart from the above, that requires consideration are

- a. Limitation in design (saturation, current density, insulation, temperature rise etc.,)
- b. Customer's needs
- c. National and international standards
- d. Convenience in production line and transportation e. Maintenance and repairs f. Environmental conditions etc.

design: The materials used for the machine and others such as cooling etc., imposes a limitation in design. The limitations stem from saturation of iron, current density in conductors, temperature, insulation, mechanical properties, efficiency, power factor etc.

a. Saturation: Higher flux density reduces the volume of iron but drives the iron to operate beyond knee of the magnetization curve or in the region of saturation. Saturation of iron poses a limitation on account of increased core loss and excessive excitation required to establish a desired value of flux. It also introduces harmonics.

b. Current density: Higher current density reduces the volume of copper but increases the losses and temperature.

c. Temperature: poses a limitation on account of possible damage to insulation and other materials.

d. Insulation (which is both mechanically and electrically weak): poses a limitation on account of breakdown by excessive voltage gradient, mechanical forces or heat.

e. Mechanical strength of the materials poses a limitation particularly in case of large and high speed machines.

f. High efficiency and high power factor poses a limitation on account of higher capital cost. (A low value of efficiency and power factor on the other hand results in a high maintenance cost).

g. Mechanical Commutation in dc motors or generators leads to poor commutation.

Apart from the above factors Consumer, manufacturer or standard specifications may pose a limitation.

1.2. Materials for Electrical Machines

The main material characteristics of relevance to electrical machines are those associated with conductors for electric circuit, the insulation system necessary to isolate the circuits, and with the specialized steels and permanent magnets used for the magnetic circuit.

Conducting materials

Commonly used conducting materials are copper and aluminum. Some of the desirable properties a good conductor should possess are listed below.

Low value of resistivity or high conductivity

Low value of temperature coefficient of resistance

High tensile strength

High melting point

High resistance to corrosion

- Allow brazing, soldering or welding so that the joints are reliable
- Highly malleable and ductile
- Durable and cheap by cost

Some of the properties of copper and aluminum are shown in the table

Sl. No	Particulars	Copper	Aluminum
1	Resistivity at 20 ⁰ C	0.0172 ohm / m/ mm ²	0.0269 ohm / m/ mm ²
2	Conductivity at 20 ⁰ C	58.14 x 10 ⁶ S/m	37.2 x 10 ⁶ S/m
3	Density at 20 ⁰ C	8933kg/m ³	2689.9m ³
4	Temperature coefficient (0-100 ⁰ C)	0.393 % per ⁰ C	0.4 % per ⁰ C
Explanation: If the temperature increases by 1 ⁰ C, the resistance increases by 0.4% in case of aluminum			
5	Coefficient of linear expansion (0-100 ⁰ C)	16.8x10 ⁻⁶ per ⁰ C	23.5 x10 ⁻⁶ per ⁰ C
6	Tensile strength	25 to 40 kg / mm ²	10 to 18 kg / mm ²
7	Mechanical property	highly malleable and ductile	not highly malleable and ductile
8	Melting point	1083 ⁰ C	660 ⁰ C
9	Thermal conductivity (0-100 ⁰ C)	599 W/m ⁰ C	238 W/m ⁰ C
10	Jointing	can be easily soldered	cannot be soldered easily

For the same resistance and length, cross-sectional area of aluminum is 61% larger than that of the copper conductor and almost 50% lighter than copper. Though the aluminum reduces the cost of small capacity transformers, it increases the size and cost of large capacity transformers. Aluminum is being much used now a day's only because copper is expensive and not easily available. Aluminum is almost 50% cheaper than Copper and not much superior to copper.

materials: The magnetic properties of a magnetic material depend on the orientation of the crystals of the material and decide the size of the machine or equipment for a given rating, excitation required, efficiency of operation etc.

The some of the properties that a good magnetic material should possess are listed below.

1. Low reluctance or should be highly permeable or should have a high value of relative permeability μ_r .

High saturation induction (to minimize weight and volume of iron parts)

High electrical resistivity so that the eddy EMF and the hence eddy current loss is less
Narrow hysteresis loop or low Coercivity so that hysteresis loss is less and efficiency of operation is high

A high curie point. (Above Curie point or temperature the material loses the magnetic property or becomes paramagnetic, that is effectively non-magnetic)

Should have a high value of energy product (expressed in joules / m³).

Magnetic materials can broadly be classified as Diamagnetic, Paramagnetic, Ferromagnetic, Antiferromagnetic and Ferrimagnetic materials. Only ferromagnetic materials have properties that are well suitable for electrical machines. Ferromagnetic properties are confined almost entirely to iron, nickel and cobalt and their alloys. The only exceptions are some alloys of manganese and some of the rare earth elements.

The relative permeability μ_r of ferromagnetic material is far greater than 1.0. When ferromagnetic materials are subjected to the magnetic field, the dipoles align themselves in the direction of the applied field and get strongly magnetized.

Further the Ferromagnetic materials can be classified as Hard or Permanent Magnetic materials and Soft Magnetic materials.

Hard or permanent magnetic materials have large size hysteresis loop (obviously hysteresis loss is more) and gradually rising magnetization curve.

Ex: carbon steel, tungsten steel, cobalt steel, alnico, hard ferrite etc.

Soft magnetic materials have small size hysteresis loop and a steep magnetization curve.

Ex: i) cast iron, cast steel, rolled steel, forged steel etc., (in the solid form).

Generally used for yokes poles of dc machines, rotors of turbo alternator etc., where steady or dc flux is involved.

Silicon steel (Iron + 0.3 to 4.5% silicon) in the laminated form. Addition of silicon in proper percentage eliminates ageing & reduce core loss. Low silicon content steel or dynamo grade

steel is used in rotating electrical machines and are operated at high flux density. High content silicon steel (4 to 5% silicon) or transformer grade steel (or high resistance steel) is used in transformers. Further sheet steel may be hot or cold rolled. Cold rolled grain oriented steel (CRGOS) is costlier and superior to hot rolled. CRGO steel is generally used in transformers.

c) Special purpose Alloys:

Nickel iron alloys have high permeability and addition of molybdenum or chromium leads to improved magnetic material. Nickel with iron in different proportion leads to

High nickel permalloy (iron +molybdenum +copper or chromium), used in current transformers, magnetic amplifiers etc.,

Low nickel Permalloy (iron +silicon +chromium or manganese), used in transformers, induction coils, chokes etc.

Perminvor (iron +nickel +cobalt)

Pemendur (iron +cobalt +vanadium), used for microphones, oscilloscopes, etc. (v)

Mumetal (Copper + iron)

d) Amorphous alloys (often called metallic glasses):

Amorphous alloys are produced by rapid solidification of the alloy at cooling rates of about a million degrees centigrade per second. The alloys solidify with a glass-like atomic structure which is non-crystalline frozen liquid. The rapid cooling is achieved by causing the molten alloy to flow through an orifice onto a rapidly rotating water cooled drum. This can produce sheets as thin as 10µm and a meter or more wide.

These alloys can be classified as iron rich based group and cobalt based group.

Material	Maximum permeability $\mu \times 10^{-3}$	Saturation magnetization in tesla	Coercivity A/m	Curie temperature $^{\circ}\text{C}$	Resistivity $\Omega\text{m} \times 10^8$
3% Si grain oriented	90	2.0	6-7	745	48
2.5% Si grain non-oriented	8	2.0	40	745	44
<0.5% Si grain non-oriented	8	2.1	50-100	770	12

Low carbon iron	3-10	2.1	50-120	770	12
78% Ni and iron	250-400	0.8	1.0	350	40
50% Ni and iron	100	1.5-1.6	10	530	60
Iron based Amorphous	35-600	1.3-1.8	1.0-1.6	310-415	120-140

Insulating materials.

To avoid any electrical activity between parts at different potentials, insulation is used. An ideal insulating material should possess the following properties.

Should have high dielectric strength.

Should with stand high temperature.

Should have good thermal conductivity

Should not undergo thermal oxidation

Should not deteriorate due to higher temperature and repeated heat cycle

Should have high value of resistivity (like $10^{18} \Omega\text{cm}$)

Should not consume any power or should have a low dielectric loss angle δ

Should withstand stresses due to centrifugal forces (as in rotating machines), electro dynamic or mechanical forces (as in transformers)

Should withstand vibration, abrasion, bending

Should not absorb moisture

Should be flexible and cheap

Liquid insulators should not evaporate or volatilize

Insulating materials can be classified as Solid, Liquid and Gas, and vacuum. The term insulating material is sometimes used in a broader sense to designate also insulating liquids, gas and vacuum.

Solid: Used with field, armature, and transformer windings etc. The examples are:

Fibrous or inorganic animal or plant origin, natural or synthetic paper, wood, card board, cotton, jute, silk etc.,

Plastic or resins. Natural resins-lac, amber, shellac etc.,

bakelite, Teflon, PVC etc

Rubber : natural rubber, synthetic rubber-butadiene, silicone rubber, hypalon, etc.,

Mineral : mica, marble, slate, talc chloride etc.,

Ceramic : porcelain, steatite, alumina etc.,

Glass : soda lime glass, silica glass, lead glass, borosilicate glass

Non-resinous : mineral waxes, asphalt, bitumen, chlorinated naphthalene, enamel etc.,

Liquid: Used in transformers, circuit breakers, reactors, rheostats, cables, capacitors etc., & for impregnation. The examples are:

Mineral oil (petroleum by product)

Synthetic oil askarels, pyranols etc.,

Varnish, French polish, lacquer epoxy resin etc.,

Gaseous: The examples are:

Air used in switches, air condensers, transmission and distribution lines etc.,

Nitrogen use in capacitors, HV gas pressure cables etc.,

Hydrogen though not used as a dielectric, generally used as a coolant

Inert gases neon, argon, mercury and sodium vapors generally used for neon sign lamps.

Halogens like fluorine, used under high pressure in cables

No insulating material in practice satisfies all the desirable properties. Therefore a material which satisfies most of the desirable properties must be selected.

1.3.Space factor:

Window space factor Kw

Window space factor is defined as the ratio of copper area in the window to the area of the window. That is

For a given window area, as the voltage rating of the transformer increases, quantity of insulation in the window increases, area of copper reduces. Thus the window space factor reduces as the voltage increases.

1.4.Choice of Specific Electrical and Magnetic loadings

Specific magnetic loading:

Following are the factors which influences the performance of the machine.

Iron loss: A high value of flux density in the air gap leads to higher value of flux in the iron parts of the machine which results in increased iron losses and reduced efficiency.

Voltage: When the machine is designed for higher voltage space occupied by the insulation becomes more thus making the teeth smaller and hence higher flux density in teeth and core.

Transient short circuit current: A high value of gap density results in decrease in leakage reactance and hence increased value of armature current under short circuit conditions.

Stability: The maximum power output of a machine under steady state condition is indirectly proportional to synchronous reactance. If higher value of flux density is used it leads to smaller number of turns per phase in armature winding. This results in reduced value of leakage reactance and hence increased value of power and hence increased steady state stability.

Parallel operation: The satisfactory parallel operation of synchronous generators depends on the synchronizing power. Higher the synchronizing power higher will be the ability of the machine to operate in synchronism. The synchronizing power is inversely proportional to the synchronous reactance and hence the machines designed with higher value air gap flux density will have better ability to operate in parallel with other machines.

Specific Electric Loading:

Following are the some of the factors which influence the choice of specific electric loadings.

Copper loss: Higher the value of q larger will be the number of armature of conductors which results in higher copper loss. This will result in higher temperature rise and reduction in efficiency.

Voltage: A higher value of q can be used for low voltage machines since the space required for the insulation will be smaller.

Synchronous reactance: High value of q leads to higher value of leakage reactance and armature reaction and hence higher value of synchronous reactance. Such machines will have poor voltage regulation, lower value of current under short

DESIGN OF ELECTRICAL APPARATUS circuit condition and low value of steady state stability limit and small value of synchronizing power.

Stray load losses: With increase of q stray load losses will increase. Values of specific magnetic and specific electric loading can be selected from Design Data Hand Book for salient and non salient pole machines.

Separation of D and L : Inner diameter and gross length of the stator can be calculated from D^2L product obtained from the output equation. To separate suitable relations are assumed between D and L depending upon the type of the generator. Salient pole machines: In case of salient pole machines either round or rectangular pole construction is employed. In these types of machines the diameter of the machine will be quite larger than the axial length.

Thermal considerations

Classification of insulating materials based on thermal consideration

Insulation class		Maximum operating temperature in °C	Typical materials
Previous	Present		
Y		90	Cotton, silk, paper, wood, cellulose, fiber etc., without impregnation or oil immersed
A	A	105	The material of class Y impregnated with natural resins, cellulose esters, insulating oils etc., and also laminated wood, varnished paper etc.
E	E	120	Synthetic resin enamels of vinyl acetate or nylon tapes, cotton and paper laminates with formaldehyde bonding etc.,
B	B	130	Mica, glass fiber, asbestos etc., with suitable bonding substances, built up mica, glass fiber and asbestos laminates.
F	F	155	The materials of Class B with more thermal resistance bonding materials
H	H	180	Glass fiber and asbestos materials and built up mica with appropriate silicone resins
C	C	>180	Mica, ceramics, glass, quartz and asbestos with binders or resins of super thermal stability.

The insulation system (also called insulation class) for wires used in generators, motors transformers and other wire-wound electrical components is divided into different classes according the temperature that they can safely withstand.

As per Indian Standard (Thermal evaluation and classification of Electrical Insulation, IS.No.1271,1985,first revision) and other international standard insulation is classified by letter grades A,E,B,F,H (previous Y,A,E,B,F,H,C).

EE8002 DESIGN OF ELECTRICAL APPARATUS The maximum operating temperature is the temperature the insulation can reach during operation and

is the sum of standardized ambient temperature i.e. 40 degree centigrade, permissible temperature rise and allowance tolerance for hot spot in winding. For example, the maximum temperature of class B insulation is (ambient temperature 40 + allowable temperature rise 80 + hot spot tolerance 10) = 130°C.

Insulation is the weakest element against heat and is a critical factor in deciding the life of electrical equipment. The maximum operating temperatures prescribed for different class of insulation are for a healthy lifetime of 20,000 hours. The height temperature permitted for the machine parts is usually about 2000C at the maximum. Exceeding the maximum operating temperature will affect the life of the insulation. As a rule of thumb, the lifetime of the winding insulation will be reduced by half for every 10 °C rise in temperature. The present day trend is to design the machine using class F insulation for class B temperature rise.

1.5.Heat flow

The heat is removed by convection, conduction and radiation. Usually, the convection through air, liquid or steam is the most significant method of heat transfer. Forced convection is, inevitably, the most efficient cooling method if we do not take direct water cooling into account. The cooling design for forced convective cooling is also straightforward: the designer has to ensure that a large enough amount of coolant flows through the machine. This means that the cooling channels have to be large enough. If a machine with open-circuit cooling is of IP class higher than IP 20, using heat exchangers to cool the coolant may close the coolant flow.

If the motor is flange mounted, a notable amount of heat can be transferred through the flange of the machine to the device operated by the motor. The proportion of heat transfer by radiation is usually moderate, yet not completely insignificant. A black surface of the machine in particular promotes heat transfer by radiation.

Conduction

There are two mechanisms of heat transfer by conduction: first, heat can be transferred by molecular interaction, in which molecules at a higher energy level (at a higher temperature) release energy for adjacent molecules at a lower energy level via lattice vibration. Heat transfer of this kind is possible between solids, liquids and gases. The second means of conduction is heat transfer between free electrons. This is typical of liquids and pure metals in particular. The number of free electrons in alloys varies considerably, whereas in materials other than metals, the number of free electrons is small. The thermal conductivity of solids depends directly on the number of free electrons. Pure metals are the best heat conductors. Fourier's law gives the heat flow transferred by conduction.

$$\Phi_{th} = -\lambda S \nabla T,$$

Where Φ_{th} is the heat flow rate, λ the thermal conductivity, S the heat transfer area and ∇T the temperature gradient.

1.6. Temperature rise

The temperature rise of a machine depends on the power loss per cooling area S

In electrical machines, the design of heat transfer is of equal importance as the electromagnetic design of the machine, because the temperature rise of the machine eventually determines the maximum output power with which the machine is allowed to be constantly loaded. As a matter of fact, accurate management of heat and fluid transfer in an electrical machine is a more difficult and complicated issue than the conventional electromagnetic design of an electrical machine. However, as shown previously in this material, problems related to heat transfer can to some degree be avoided by utilizing empirical knowledge of the machine constants available. When creating completely new constructions, empirical knowledge is not enough, and thorough modeling of the heat transfer is required. Finally, prototyping and measurements verify the successfulness of the design. The problem of temperature rise is twofold: first, in most motors, adequate heat removal is ensured by convection in air, conduction through the fastening surfaces of the machine and radiation to ambient. In machines with a high power density, direct cooling methods can also be applied. Sometimes even the winding of the machine is made of copper pipe, through which the coolant flows during operation of the machine. The heat transfer of electrical machines can be analyzed adequately with a fairly simple equation for heat and fluid transfer.

The most important factor in thermal design is, however, the temperature of ambient fluid, as it determines the maximum temperature rise with the heat tolerance of the insulation. Second, in addition to the question of heat removal, the distribution of heat in different parts of the machine also has to be considered. This is a problem of heat diffusion, which is a complicated three-dimensional problem involving numerous elements such as the question of heat transfer from the conductors over the insulation to the stator frame. It should be borne in mind that the various empirical equations are to be employed with caution. The distribution of heat in the machine can be calculated when the distribution of losses in different parts of the machine and the heat removal power are exactly known. In transients, the heat is distributed completely differently than in the stationary state. For instance, it is possible to overload the motor considerably for a short period of time by storing the excess heat in the heat capacity of the machine

1.7. Rating of machines

Rating of a motor is the power output or the designated operating power limit based upon certain definite conditions assigned to it by the manufacturer.

The rating of machine refer to the whole of the numerical values of electrical and mechanical quantities with their duration and sequence assigned to the machines by the manufacturer and stated on the rating plate, the machine complying with the specified conditions.

Rating of a single phase & three phase transformer in KVA is given as

$$= 2.22 f B_m \delta K_w A_w A_i * 10^{-3} Q$$

$$= 3.33 f B_m \delta K_w A_w A_i * 10^{-3}$$

Where f = frequency, Hz

B_m = maximum flux density, Wb/m²

δ = current density, A/mm²

K_w = Window space factor

A_w = Window area, m²

A_i = Net core area, m²

1.8. Standard specifications.

Output : kW (for generators), kW or Hp (for motors)

Voltage : V volt

Speed : N rpm

Rating : Continuous or Short time

Temperature rise: $\theta^{\circ}\text{C}$ for an ambient temperature of 40°C

Cooling : Natural or forced cooling

Type: Generator or motor, separately excited or self-excited-shunt, series, or compound, if compound type of connection – long or short shunt, type of compounding – cumulative or differential, degree of compounding – over, under or level. With or without inter poles, with or without compensating windings, with or without equalizer rings in case of lap winding.

Voltage regulation (in case of generators) : Range and method

Speed control (in case of motors) : range and method of control

Efficiency: must be as for as possible high (As the efficiency increases, cost of the machine also increases).

Type of enclosure: based on the field of application – totally enclosed, screen protected, drip proof, flame proof, etc.,

Size of the machine etc.,

QUESTION BANK

Unit-I INTRODUCTION

1.What are the types of electrical engineering materials?

Basically there are three types of materials used in electrical machines.

- Magnetic materials
- Conducting materials
- Insulating materials

2.What is meant by critical magnetic field?

If the temperature of a material is raised above its critical temperature its superconductivity disappears. The field at which superconductivity vanishes is called critical magnetic field.

3. What is askarel?

An askarel is a synthetic non flammable insulating liquid. The commonest askarel is hexa choloro diphyanyl tricholoro benzene.

Name the magnetic materials used for Yoke, Transformer Stampings and permanent magnet.

Yoke of a dc machine, transformer stamping, permanent magnet

Yoke of a dc machine – cast steel

Transformer stamping – silicon steel

Permanent magnet – hard magnetic material (Al, Ni, Co)

Comment on the use of CRGOS strip wound transformer core.

CRGOS means cold rolled grain oriented steel. This steel is manufactured by series of cold reductions and intermediate annealings. This could reduce the material has strong directional of highest permeability which results less hysteresis loss. This type of material is suitable for use in transformers.

6. What is meant by heating?

The temperature of a machine rises when it runs under load condition starting from cold condition. The temperature raises is directly proportional to the power wasted. The heat dissipation may be due to conduction, convection or radiation.

7. What is meant by cooling?

The cooling medium like air, water or gas is provided to absorb the heat energy to save the machine. The cooling medium is also called coolent. The cooling is of two types like, direct and indirect cooling.

8. What is meant by radiation?

If the heat energy is transferred from one place to other with air of gas it is called radiation.

What are the electrical properties of insulating materials?

- high dielectric strength
- high resistivity
- low dielectric hysteresis
- good thermal conductivity
- high thermal stability

Classification of insulating materials.

There are seven classes of insulating materials used in electrical machines according to their thermal stability in service.

CLASS	TEMPERATURE
Y	90°C
A	105° C

E	120 °C
B	130 °C
F	155 °C
H	180 °C
C	ABOVE 180° C

11. What are the constructional elements of a transformer?

The constructional elements of a transformer are core, high and low voltage windings, cooling tubes or radiators and tank.

How the design problems of an electrical machine can be classified? The

design problems of electrical machine can be classified as:

- Electromagnetic design
- Mechanical design
- Thermal design
- Dielectric design

List the constructional elements of a d.c. machine?

The major constructional elements of a d.c. machine are stator, rotor, brushes and brush holders.

The various parts of stator and rotor are listed below:

Stator - Yoke (or) Frame	Rotor - Armature core
Field pole	Armature winding
Pole shoe	Commutator
Field winding	
Interpole	

14. How is total m.m.f. calculated?

The total mmf required to establish the flux in the magnetic circuit is calculated using the knowledge of dimensions and configuration of the magnetic circuit. The magnetic circuit is split up into conventional parts, which may be connected in series or parallel. The flux density is calculated in every part and m.m.f. per unit length; 'at' is found by consulting 'B-H' curves. The summation of m.m.f.s in series gives the total m.m.f.

List the methods used for determining the motor rating for variable load drives.

- Method of average losses
- Equivalent current methods
- Equivalent torque method
- Equivalent power method

Define rating.

Rating of a motor is the power output or the designated operating power limit based upon certain definite conditions assigned to it by the manufacturer.

17. What are the problems that arise during the calculation of m.m.f. for air gap?

The iron surfaces around the air gap are not smooth and so the calculation of m.m.f. for the airgap by ordinary methods gives wrong results. The problem is complicated by the fact that

One or both of the iron surfaces around the air gap may be slotted so that the flux tends to concentrated on the teeth rather than distributing itself uniformly over the air gap.

There are radial ventilating ducts in the machine for cooling purposes which effect in a similar manner as above.

In salient pole machine, the gap dimensions are not constant over whole of the pole pitch.

Mention the methods used for calculating the mmf for tapered teeth.

- Graphical method
- Three ordinate method (Simpson's Rule)

Bt 1/3 Method

What is Carter’s gap co-efficient?

The Carter’s gap co-efficient (K_{CS}) is the ratio of slot width to gap length. The formula which gives the value of K_{CS} directly is

$$K_{CS} = 1 / [1 + (5 l_g / W_s)]$$

Where l_g = gap length; W_s = Width of slot

The other formula for Carter’s gap co-efficient (K_{CS}) for parallel sided open slot is

$$K_{CS} = 2/\Pi [\tan^{-1} y - 1/ \Pi \log \text{SQRT} (1+ \Pi^2)]$$

Where $y = W_s / 2 l_g$.

Write down the expression for calculation of reluctance of air gap with slotted Armature.

Reluctance of air gap with slotted armature

$$S_g = l_g / \mu y_s L = l_g / \mu_0 L (y_s - K_{CS} W_s)$$

Where l_g = gap length; y_s = slot pitch; K_{CS} = Carter’s co-efficient; W_s = Width of slot.

21. Define field form factor.

Field form factor K_f is defined as

$$K_f = \frac{\text{Average gap density over the pole pitch } B_{av}}{\text{Maximum flux density in the gap } B_g}$$

Where B_{av} = Flux per pole / area per pole = $\phi / (\Pi D / p) * L$

Define stacking factor.

Stacking factor is defined as the ratio of actual length of iron in a stack of assembled core plates to total axial length of stack.

23. What is gap contraction factor for slots?

The ratio of reluctance of air gap of slotted armature to reluctance of air gap of smooth armature is called gap contraction factor for slots.

$$K_{gs} = \frac{Y_s}{Y_s - K_{CS} W_s}$$

24. What is gap contraction factor for ducts?

The ratio of reluctance of air gap with ducts to reluctance of air gap without ducts is known as gap contraction factor for ducts.

$$K_{gd} = \frac{L}{L - K_{cd} n_d W_d}$$

Where L = Length of core; K_{cd} = Carter’s co-efficient for ducts ;

n_d = number of radial ducts; W_d = Width of each duct

Write the expression for mmf of air gap with smooth and slotted armatures.

M.M.F. for air gap with smooth armature is $AT_g = 8,00,000 B l_g$ M.M.F.

for air gap with slotted armature is $AT_g = 8,00,000 K_g B l_g$ Where K_g is gap expansion factor; B is flux density; l_g is gap length.

Mention the problems encountered while calculating the mmf for teeth.

The calculation of mmf necessary to maintain the flux in the teeth is difficult during the following problems:

The teeth are wedge-shaped or tapered when parallel sided slots are used. This means that the area presented to the path of flux is not constant and this gives different values of flux density over the length of teeth.

The slot provides another parallel path for flux, shunting the tooth. The teeth are normally worked in the saturation region and therefore their permeability is low and as a result an appreciable portion of the flux goes down the depth of slots.

Explain why real flux density in the teeth is less than the apparent flux density.

The slot provides an alternate path for the flux to pass, although the flux entering an armature from the air gap follows paths principally. If the teeth density is high, the mmf acting across the teeth is very large and as the slots are in parallel with the teeth, this mmf acts, across the slots also. Thus at saturation density, the flux passing through the slots become large and cannot be neglected and calculation based on ‘no slot flux’ leads to wrong results. This shows that the real flux passing through the teeth is always less than the total or apparent flux. As a result, the real flux density in the teeth is always less than the apparent flux density.

28. What is meant by apparent and real flux density?

$$\text{Apparent flux density } B_{\text{app}} = \frac{\text{Total flux in a slot pitch}}{\text{Tooth area}}$$

$$\text{Real flux density } B_{\text{real}} = \frac{\text{Actual flux in a tooth}}{\text{Tooth area}}$$

29. What is meant by rating of a machine?

The rating of machine refer to the whole of the numerical values of electrical and mechanical quantities with their duration and sequence assigned to the machines by the manufacturer and stated on the rating plate, the machine complying with the specified conditions.

30. Mention the different types of duties of a machine.

The following are the types of duty as per IS : 4722 – 1968 “ Specification for rotating electric machinery”

- S₁ = Continuous duty
- S₂ = Short time duty
- S₃ = Intermittent periodic duty
- S₄ = Intermittent periodic duty with starting
- S₅ = Intermittent periodic duty with starting and braking
- S₆ = Continuous duty with intermittent periodic loading
- S₇ = Continuous duty with starting and braking
- S₈ = Continuous duty with periodic speed changes

Define continuous rating.

The continuous rating of a motor is defined as the load that may be carried by the machine for an indefinite time without the temperature rise of any part exceeding the maximum permissible value.

32. Define short time rating.

The short time rating of a motor may be defined as its output at which it may be operated for a certain specified time without exceeding the maximum permissible value of temperature rise.

33. Define duty factor.

The duty factor (also called load factor or cyclic duration factor) is defined as the ratio of the heating period to the period of whole cycle.

$$\text{Duty Factor } \epsilon = \frac{t_h}{t_h + t_e}$$

What is meant by intermittent rating?

The intermittent rating of a motor applies to an operating condition during which short time. Load periods alternate with period of rest or no load without the motor reaching the thermal equilibrium and without the maximum temperature rising above the maximum permissible value.

What are the major considerations to evolve a good design of electrical machine?

The major considerations to achieve a good electrical machine are

- Specific electric loading
- Specific magnetic loading
- Temperature rise
- Efficiency
- Length of air gap
- Power factor

List the standard specifications for transformer.

IS 1180 – 1989 : Specifications for out door 3-phase distribution transformer Upto

100 KVA.

IS 2026 – 1972 : Specifications of power transformers

What is magnetic circuit?

The magnetic circuit is the path of magnetic flux. The mmf of the circuit creates flux in the path against the reluctance of the path. The equation which relates flux, mmf and reluctance is given by

$$\text{Flux} = \frac{\text{mmf}}{\text{Reluctance}}$$

Write any two essential differences between magnetic and electric circuits.

When the current flows in the electric circuit the energy is spent continuously, whereas in magnetic circuit the energy is needed only to create the flux but not to maintain it.

Current actually flows in the electric circuit, whereas the flux does not flow in a magnetic circuit but it is only assumed to flow.

What is magnetization curve?

The magnetization curve is a graph showing the relation between the magnetic field intensity, H and the flux density, B of a magnetic circuit. It is used to estimate the mmf required for flux path in the magnetic material and it is supplied by the manufacturers of stampings and laminations.

40. What is loss curve?

The loss curve is a graph showing the relation between iron loss and magnetic field intensity, H. It is used to estimate the iron loss of the magnetic materials and it is supplied by the manufacturers of stampings and laminations.

What is the difference in permeability of magnetic and non-magnetic materials?

In magnetic materials the permeability is not constant and it depends on the saturation of the magnetic material. But in non-magnetic materials the permeability is constant.

How to find total mmf in a series circuit?

The various steps in estimation of mmf of a section of magnetic circuit are:

Determine the flux in the concerned section.

Calculate the area of cross-section of the section.

Calculate the flux density in the section

From B – at curve of the magnetic material, determine the mmf per meter(at) for the calculated flux density

The mmf of the section is given by the product of length of the section and mmf per metre.

List the different types of slots that are used in rotating machines.

The different types of slots are

- Parallel sided slots with flat bottom
- Parallel sided slots with circular bottom
- Tapered slots with flat bottom
- Tapered slots with circular bottom
- Circular slots

Mention the undesirable effects of unbalanced magnetic pull.

The undesirable effects of unbalanced magnetic pull are

- Saturation of magnetic materials due to reduction in air gap.
- Excessive vibration and noise due to unbalanced radial forces

Mention the importance of conductor dimensions.

The dimension of the conductors directly affects the following factors in rotating machines:

- Allowable temperature rise
- Resistivity
- Current density
- Specific electric loading

Define slot space factor or slot insulation factor.

The slot space factor is defined as the ratio of conductor area to slot area.

$$\text{Slot Space Factor} = \frac{\text{Conductor Area}}{\text{Slot Area}}$$

47. What do you understand by slot pitch?

The slot pitch is defined as the distance between centers of two adjacent slots measured in linear scale.

$$\text{Slot pitch } Y_s = \frac{D}{S_s}$$

Where D = Diameter of armature

S_s = Number of slots in armature

State the parameters governing slot utilization factor or slot space factor.

The following factors decide the slot utilization factor:

- Voltage rating
- Thickness of insulation
- Number of conductors per slot
- Area of cross-section of the conductor
- Dimensions of the conductor

Define specific permeance of a slot.

Specific permeance of a slot is defined as the permeance per unit length of slot or depth of field.

50. What is unbalanced magnetic pull?

The unbalanced magnetic pull is the radial force acting on the rotor due to non-uniform air-gap around armature periphery.

UNIT II DC MACHINES

Output Equations – Main Dimensions - Magnetic circuit calculations – Carter’s Coefficient
 – Net length of Iron –Real & Apparent flux densities – Selection of number of poles – Design of Armature – Design of commutator and brushes – performance prediction using design values.

2.1.Introduction:

The size of the DC machine depends on the main or leading dimensions of the machine viz., diameter of the armature D and armature core length L . As the output increases, the main dimensions of the machine D and L also increases.

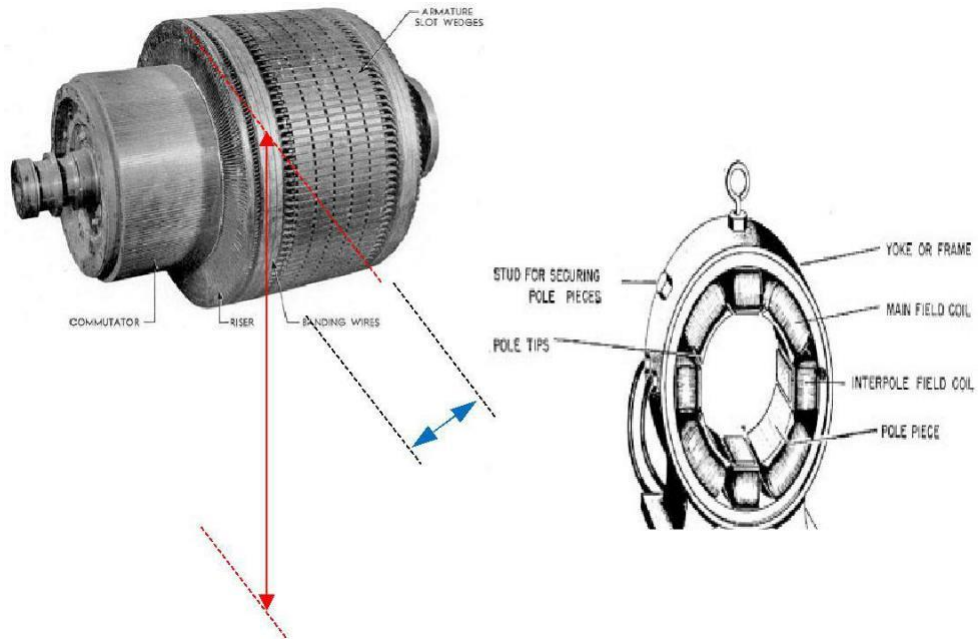
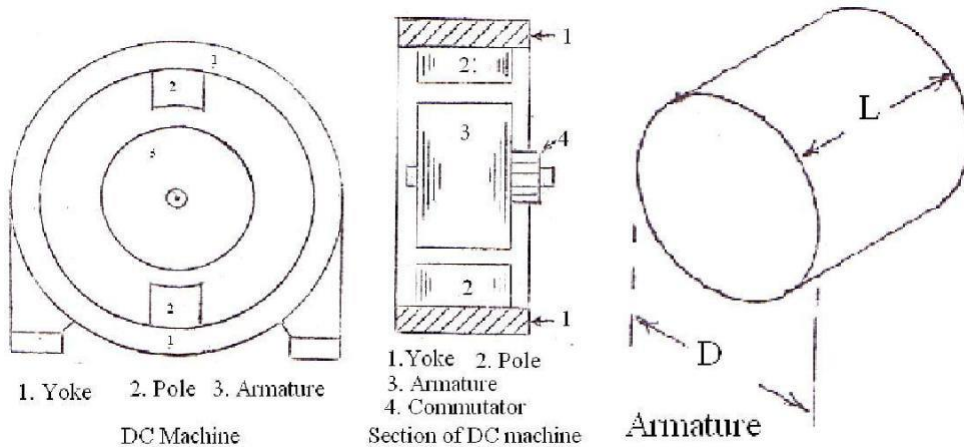

Fig Armature of a dc machine Fig. Yoke and pole arrangement of a dc machine



2.2. Output Equations and Main Dimensions of DC Machine

Note: Output equation relates the output and main dimensions of the machine. Actually it relates the power developed in the armature and main dimensions.

E : EMF induced or back EMF

I_a : armature current

φ : Average value of flux / pole

Z : Total number of armature conductors

N : Speed in rpm

P : Number of poles

A : number of armature paths or circuits

D : Diameter of the armature

L : Length of the armature core

Power developed in the armature in kW = E I_a × 10⁻³

$$(\phi Z N P/60 A) \times I_a \times 10^{-3}$$

$$(P\phi) \times (I_a Z/A) \times N \times 10^{-3}/60 \dots\dots (1)$$

The term P φ represents the total flux and is called the magnetic loading. Magnetic loading/unit area of the armature surface is called the specific magnetic loading or average value of the flux density in the air gap B_{av}. That is,

$$B_{av} = P\phi / \pi DL \text{ Wb/m}^2 \text{ or tesla denoted by T}$$

$$\text{Therefore } P\phi = B_{av} \pi DL \dots\dots\dots (2)$$

The term (I_a Z/A) represents the total ampere-conductors on the armature and is called the electric loading. Electric loading/unit length of armature periphery is called the specific electric loading q. That is,

$$\text{Therefore } I_a Z/A = q \pi D \dots\dots\dots (3)$$

Substitution of equations 2 and 3 in 1, leads to

$$\text{kW} = B_{av} \pi DL \times q \pi D \times (N \times 10^{-3}/ 60)$$

$$1.64 \times 10^{-4} B q D^2 L N$$

$$C_0 D^2 L N$$

Where C₀ is called the output coefficient of the DC machine and is equal to 1.64 x 10⁻⁴

$$Bq. \text{ Therefore } D^2 L = (Kw/1.64 \times 10^{-4} B q N) \text{ m}^3$$

The above equation is called the output equation. The D^2L product represents the size of the machine or volume of iron used. In order that the maximum output is obtained /kg of iron used, D^2L product must be as less as possible. For this, the values of q and B_{av} must be high.

Effect of higher value of q

Note: Since armature current I_a and number of parallel paths A are constants and armature diameter D must be as less as possible or D must be a fixed minimum value, the number of armature conductors increases as $q = I_a Z / A \pi D$ increases.

a. As q increases, number of conductors increases, resistance increases, I^2R loss increases and therefore the temperature of the machine increases. Temperature is a limiting factor of any equipment or machine.

b. As q increases, number of conductors increases, conductors/slot increases, quantity of insulation in the slot increases, heat dissipation reduces, temperature increases, losses increases and efficiency of the machine reduces.

c. As q increases, number of conductors increases, armature ampere-turns per pole $AT_a / \text{pole} = (I_a Z / 2 A P)$ increases, flux produced by the armature increases, and therefore the effect of armature reaction increases. In order to overcome the effect of armature reaction, field MMF has to be increased. This calls for additional copper and increases the cost and size of the machine.

d. As q increases, number of conductors and turns increases, reactance voltage proportional to $(\text{turns})^2$ increases. This leads to sparking commutation.

Effect of higher value of B_{av}

a. As B_{av} increases, core loss increases, efficiency reduces.

b. As B_{av} increases, degree of saturation increases, mmf required for the magnetic circuit increases. This calls for additional copper and increases the cost of the machine.

It is clear that there is no advantage gained by selecting higher values of q and B_{av} . If the values selected are less, then D^2L will be large or the size of the machine will unnecessarily be high. Hence optimum value of q and B_{av} must be selected.

In general q lies between 15000 and 50000 ampere-conductors/m.

Lesser values are used in low capacity, low speed and high voltage machines. In general B_{av} lies between 0.45 and 0.75 T.

SEPARATION OF D^2L PRODUCT

Knowing the values of kW and N and assuming the values of q and B_{av} , a value

for $D^2L = kW / 1.64 \times 10^{-4} \times B_{av} q N$ can be calculated.

Since the above expression has two unknowns namely D and L, another expression relating D and L must be known to find out the values of D and L.

Usually a value for the ratio armature core length L to pole pitch is assumed to separate D2L product. The pole pitch τ refers to the circumferential distance corresponding one pole at diameter D. In practice L / τ lies between 0.55 and 1.1.

$$\begin{aligned} \text{Therefore } L &= (0.55 \text{ to } 1.1) \tau \\ &= (0.55 \text{ to } 1.1) \pi D / P \\ \text{If } L/\tau &= 1.0 \text{ and } P = 4, \text{ then } L = 1.0 \times \pi D / P \\ &= 1.0 \times \pi D / 4 = 0.785D. \end{aligned}$$

Therefore $D^2 \times 0.785 D = 0.1$ or $D = 0.5\text{m}$. Thus $L = 0.785 \times 0.5 = 0.395 \text{ m}$.

Note: The D2 L product can also be separated by assuming a value for the peripheral velocity of the armature.

2.3.Magnetic circuit calculations

The different parts of the dc machine magnetic circuit / pole are yoke, pole, air gap, armature teeth and armature core. Therefore, the ampere magnetic circuit is the sum of the ampere That is,

$$AT / \text{pole} = AT_y + AT_p + AT_g$$

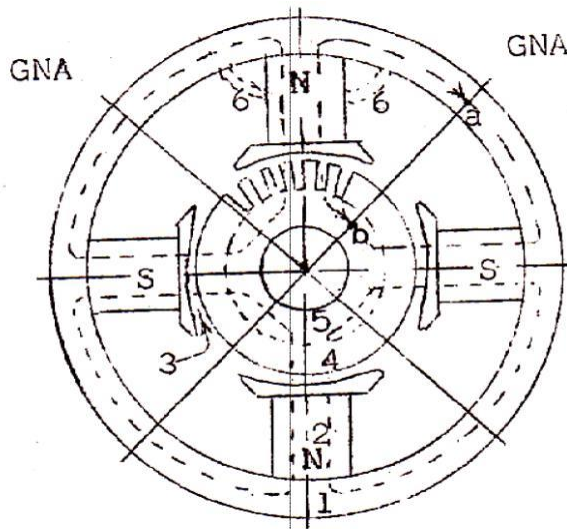

Yoke, 2. Pole, 3. Air gap, 4. Armature teeth, 5. Armature core, 6. Leakage flux
 ab: Mean length of the flux path corresponding to one pole

Magnetic circuit of a 4 pole DC machine

Note: Leakage factor or Leakage coefficient LC.

All the flux produced by the pole will not pass through the desired path i.e., air gap. Some of the flux produced by the pole will be leaking away from the air gap. The flux that passes through the air gap and cut by the armature conductors is the useful flux and that flux that leaks away from the desired path is the leakage flux

$$\text{Thus } \phi_p = \phi + \phi_l$$

As leakage flux is generally around (15 to 25) % of ϕ ,

$$\begin{aligned} \phi_p &= \phi + (0.15 \text{ to } 0.25) \phi \\ &= LC \times \phi \end{aligned}$$

where LC is the Leakage factor or Leakage coefficient and lies between (1.15 to 1.25). Magnitude of flux in different parts of the magnetic circuit

Flux in the yoke

Flux in the pole

Flux in the air gap

Flux in the armature teeth

Flux in the armature core

Reluctance of the air gap

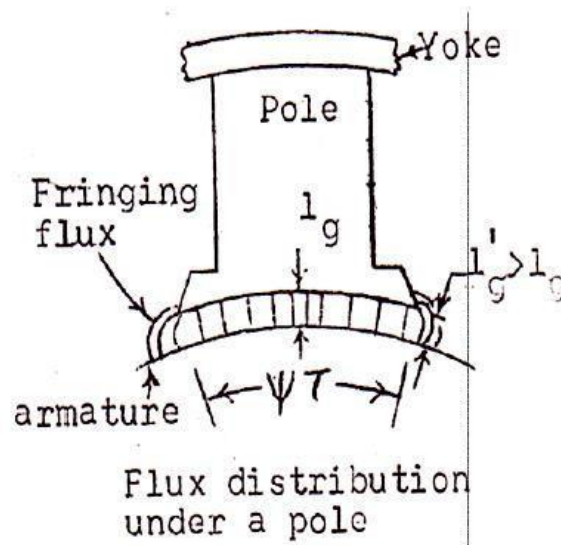

Where

l_g = Length of air gap

t = Width (pole arc) over which the flux is passing in the air

gap L = Axial length of the armature core

$y t L$ = Air gap area / pole over which the flux is passing in the air gap

PROBLEMS:

EX.1. Calculate the ampere turns required for the air gap of a DC machine given the following data.

Gross core length = 40cm, air gap length = 0.5 cm, number of ducts = 5, width of each duct = 1.0cm, slot pitch = 6.5cm, average value of flux density in the air gap = 0.63T. Field form factor = 0.7, Carter's coefficient = 0.82 for opening/gap length = 1.0 and Carter's coefficient = 0.82 for opening/gap length = 1.0, and Carter's coefficient = 0.72 for opening/gap length = 2.0.

EX.2. Find the ampere-turns/pole required for a dc machine from the following data. Radical length of the air gap = 6.4mm, tooth width = 18.5 mm, slot width = 13.5mm, width of core packets = 50.8mm, width of ventilating ducts = 9.5mm, Carter's coefficient for slots and ducts = 0.27 and 0.21, maximum gap density = 0.8T. Neglect the ampere turns for the iron parts.

EX.3. Find the ampere turns required for the air gap of a 6pole, lap connected dc machine with the following data. No load voltage = 250V, air gap length = 0.8cm, pole pitch = 50cm, pole arc = 33cm, Carter's coefficient for slots and ducts = 1.2, armature conductors = 2000, speed = 300RPM, armature core length = 30cm.

EX.4. Calculate the ampere turns for the air gap of a machine using the following data. Core length = 32cm, number of ventilating ducts = 4, width of duct = 1.0cm, pole arc of ventilating ducts = 4, width of duct = 1.0cm, pole arc = 19cm. Slot pitch = 5.64 cm, semi-closed slots with slot opening = 0.5cm, air gap length = 0.5cm, flux/pole = 0.05Wb.

EX.5. A DC machine has an armature diameter of 25cm, core length of 12cm, 31 parallel slots 1.0cm wide and 3.0cm deep. Insulation on the lamination is 8.0%. The air gap is 0.4cm long and there is one radial duct 1cm wide in the core. Carter's coefficient for the slots and the duct is 0.68. Determine the ampere turns required for the gap and teeth if the flux density in the gap is 0.7T. The magnetization curve for the iron is:

Flux density in tesla	1.4	1.6	1.8	2.0	2.1	2.2	2.3
ampere- turns/cm	18	30	65	194	344	630	1200

EX.6. Find the ampere turns/pole required to drive the flux through the teeth using Simpson’s rule with the following data: flux/pole = 0.07Wb, core-length = 35cm, number of ducts = 4, width of each duct = 1.0cm, slot pitch at the gap surface = 2.5cm, slot pitch at the root of the tooth = 2.3cm, dimensions of the slot = 1.2cm x 5cm, slots/pole-pitch = 12

EX.7. Find the ampere turns required to drive the flux through the teeth with the following data using graphical method. Minimum tooth width = 1.1cm, maximum tooth width = 1.5cm, slot depth 4.0cm, maximum value of flux density at the minimum tooth section = 2.0T. Material used for the armature is Stalloy.

EX.8. Calculate the apparent flux density at a section of the tooth of the armature of a DC machine with the following data at that section. Slot pitch = 2.4cm, slot width = 1.2 cm, armature core length including 5 ducts each 1.0cm wide = 38cm, stacking factor = 0.92, true flux density in the teeth at the section is 2.2T for which the ampere turns/m is 70000.

EX.9. Calculate the apparent flux-density at a particular section of a tooth from the following data. Tooth width = 12mm, slot width = 10mm, gross core length = 0.32mm, number of ventilating ducts = 4, width of the duct each = 10mm, real flux density = 2.2T, permeability of teeth corresponding to real flux density = $31.4 \times 10^{-6} \text{H/m}$. Stacking factor = 0.9.

EX.10. The armature core of a DC machine has a gross length of 33cm including 3 ducts each 10mm wide, and the iron space factor is 0.9.If the slot pitch at a particular section is 25 mm and the slot width 14mm, estimate the true flux density and the MMF/m for the teeth at this section corresponding to an apparent flux/density of 23T. The magnetization curve data for the armature stamping is,

B in tesla	1.6	1.8	1.9	2.0	2.1	2.2	2.3
At/m	3700	10000	17000	27000	41000	70000	109000

2.4.Carter’s Coefficient

Carter’s gap expansion coefficient

$$S_{SSA} = \frac{l_g}{\lambda_s L \mu_0} \text{ ----- (1)}$$

$$S_{AWS} = \frac{l_g}{(b_t + b_s \delta_s) L \mu_0} \text{ ----- (2)}$$

$$\frac{S_{AWS}}{S_{SSA}} = \frac{l_g / (b_t + b_s \delta_s) L \mu_0}{l_g / \lambda_s L \mu_0} \quad S_{AWS} = \frac{\lambda_s \times S_{SSA}}{(b_t + b_s \delta_s)}$$

$$= \frac{\lambda_s \times S_{SSA}}{b_t + b_s \delta_s + b_s - b_s}$$

$$S_{AWS} = \frac{\lambda_s \times S_{SSA}}{\lambda_s - b_s (1 - \delta_s)} = K_{gs} \times S_{SSA}$$

Where K_{gs} is called the Carter's gap expansion coefficient for slots and is greater than 1.0.

2.5.Net length of Iron

$$L_i = \text{Net iron length of the armature core} = K_i (L - n_v b_v)$$

2.6.Real & Apparent flux densities

Although a detailed description of the design of a DC machine is beyond the scope of this material, some design principles are still worth mentioning. The methods presented previously are applicable to the design of a DC machine with certain adjustments. One of the most important special features of a DC machine is the armature reaction and, in particular, its compensation.

According to the IEC, the armature reaction is the current linkage set up by the currents in the armature winding or, in a wider sense, the resulting change in the air-gap flux. Since the brushes are on the quadrature axis, the armature current produces the armature reaction also in the quadrature direction; that is, transversal to the field-winding-generated flux. Figure depicts the armature reaction in the air gap of a non compensated DC machine.

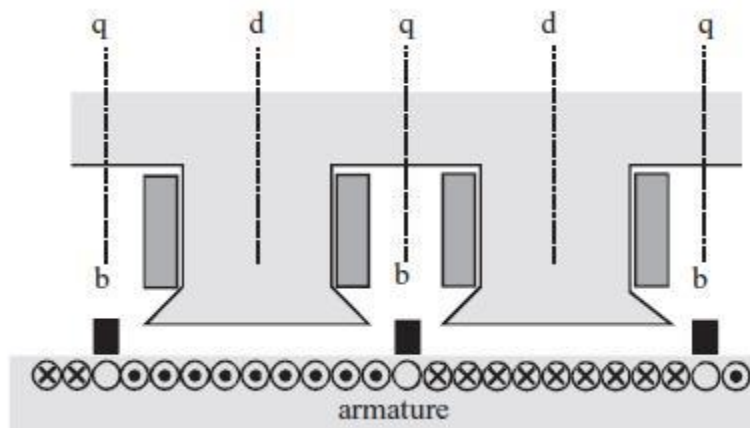

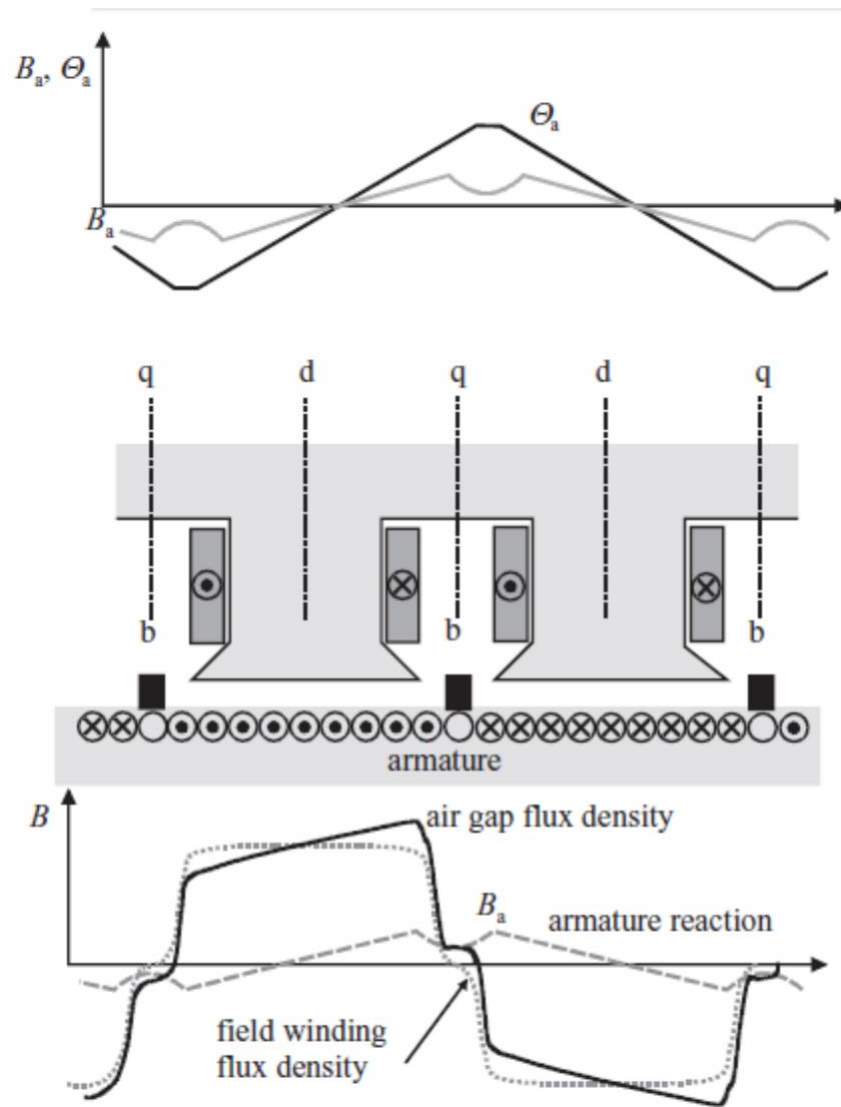

Resulting air-gap flux density as a sum of the field winding flux density and the armature reaction. As a result of the armature reaction, the flux densities at the quadrature axes are not zero. This is harmful for the commutation of the machine

2.7. Selection of number of poles

As the armature current increases, cross sectional area of the conductor and hence the eddy current loss in the conductor increases. In order to reduce the eddy current loss in the conductor, cross-sectional area of the conductor must be made less or the current / path must be restricted.

For a normal design, current / parallel path should not be more than about 200A. However, often, under enhanced cooling conditions, a current / path of more than 200A is also being used. By selecting a suitable number of paths for the machine, current / path can be restricted and the number of poles for the machine can be decided. While selecting the number of poles, the following conditions must also be considered as far as possible.

In order to decide what number of poles (more or less) is to be used, let the different factors affecting the choice of number of poles be discussed based on the use of more number of poles.

- Frequency
- Weight of the iron used for the yoke
- Weight of iron used for the armature core (from the core loss point of view)
- Weight of overhang copper
- Armature reaction
- Overall diameter
- Length of the commutator
- Flash over
- Labour charges

Frequency

As the number of poles increases, frequency of the induced EMF — increases core loss in the armature increases and therefore efficiency of the machine decreases.

Weight of the iron used for the yoke

Since the flux carried by the yoke is approximately $\phi/2$ and the total flux $\phi_T = p\phi$ is a constant for a given machine, flux density in the yoke

It is clear that B is $\propto 1/P$

As B is also almost constant for a given iron. Thus, as the number of poles increases, And hence the weight of iron used for the yoke reduces.

Weight of iron used for the armature core (from the core loss point of view)

Since the flux carried by the armature core is $\phi/2$, eddy current loss in the armature core

— => is independent of the number of poles.

Weight of overhang copper: For a given active length of the coil, overhang \propto pole pitch goes on reducing as the number of poles increases. As the overhang length reduces, the weight

of the inactive copper used at the overhang also reduces.

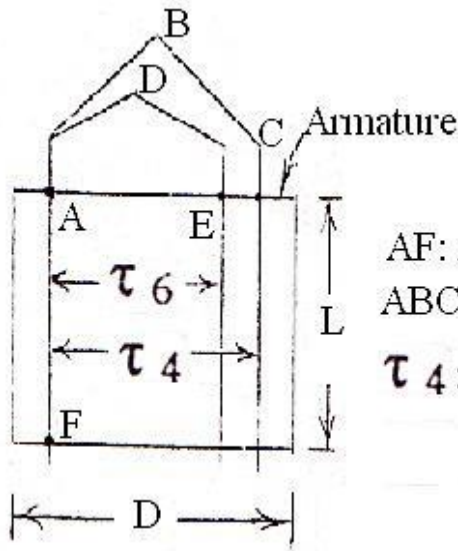

AF: Active length of the coil
 ABC or ADE : Overhang or inactive part of the coil
 τ_4 : Pole pitch in case of 4 pole machine
 τ_6 : Pole pitch in case of 6 pole machine

Armature reaction

Since the flux produced by the armature and armature ampere turns

Overall diameter

When the number of poles is less, AT_a / pole and hence the flux, produced by the armature is more. This reduces the useful flux in the air gap. In order to maintain a constant value of air gap flux, flux produced by the field or the field ampere-turns must be increased. This calls for more field coil turns and size of the coil defined by the depth of the coil d_f and height of the coil h_f increases. In order that the temperature rise of the coil is not more, depth of the field coil is generally restricted. Therefore height of the field coil increases as the size of the field coil or the number of turns of the coil increases. As the pole height, is proportional to the field coil height, height of the pole and hence the overall diameter of the machine increases with the increase in height of the field coil.

Obviously as the number of poles increases, height of the pole and hence the overall diameter of the machine decreases.

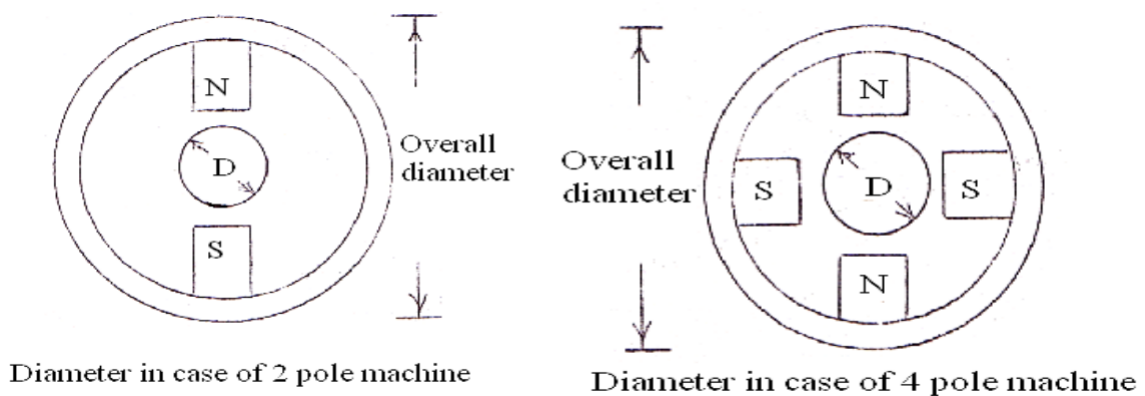

Length of the commutator

Since each brush arm collects the current from every two parallel paths

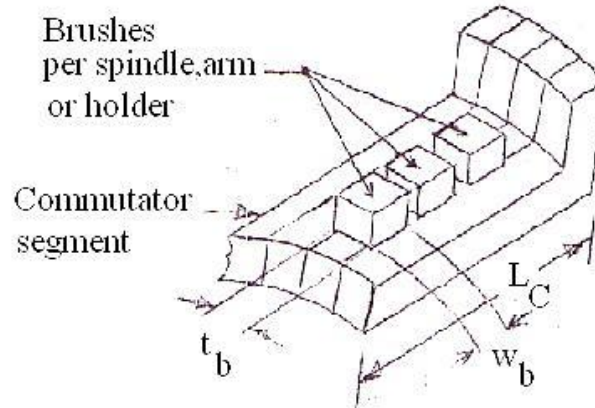

A portion of the commutator

2.8.Design of Armature

The armature winding can broadly be classified as concentrated and distributed winding.

In case of a concentrated winding, all the conductors / pole is housed in one slot. Since the conductors / slot is more, quantity of insulation in the slot is more, heat dissipation is less, temperature rise is more and the efficiency of operation will be less. Also emf induced in the armature conductors will not be sinusoidal. Therefore

- design calculations become complicated (because of the complicated expression of non-sinusoidal wave).
- Core loss increases (because of the fundamental and harmonic components of the non-sinusoidal wave) and efficiency reduces.
- Communication interference may occur (because of the higher frequency components of the non-sinusoidal wave).

Hence no concentrated winding is used in practice for a DC machine armature.

In a distributed winding (used to overcome the disadvantages of the concentrated winding), conductors / pole is distributed in more number of slots. The distributed winding can be classified as single layer winding and double layer winding.

In a single layer winding, there will be only one coil side in the slot having any number of conductors, odd or even integer depending on the number of turns of the coil. In a double layer winding,

EE8002 DESIGN OF ELECTRICAL APPARATUS there will be 2 or multiple of 2 coil sides in the slot arranged in two layers. Obviously conductors / slot in a double layer winding must be an even integer.

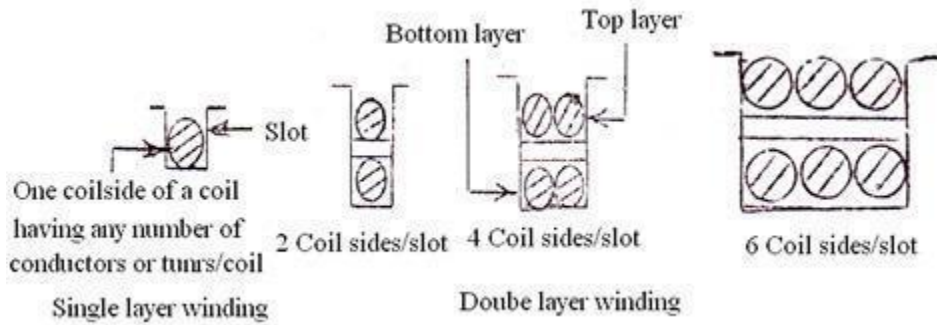

Since for a given number of conductors, poles and slots, a single layer winding calls for less number of coils of more number of turns, reactance voltage proportional to $(\text{turn})^2$ is high. This decreases the quality of commutation or leads to sparking commutation. Hence a single layer winding is not generally used in DC machines. However it is much used in alternators and induction motors where there is no commutation involved.

Since a double layer winding calls for more number of coils of less number of turns/coil, reactance voltage proportional to $(\text{turn})^2$ is less and the quality of commutation is good. Hence double layer windings are much used in DC machines.

Unless otherwise specified all DC machines are assumed to be having a double layer winding.

A double layer winding can further be classified as simplex or multiplex and lap or wave winding.

In order to decide what number of slots (more or less) is to be used, the following merits and demerits are considered.

As the number of slots increases, cost of punching the slot increases, number of coils increases and hence the cost of the machine increases.

As the number of slots increases, slot pitch

$$\lambda_s = (\text{slot width } b_s + \text{tooth width } b_t)$$

$\pi D /$ number of slots decreases and hence the tooth width reduces. This makes the tooth mechanically weak, increases the flux density in the tooth and the core loss in the tooth. Therefore efficiency of the machine decreases.

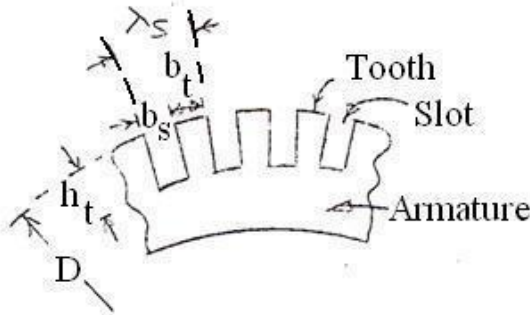

Fig. Armature Dimension view

If the slots are less in number, then the cost of punching & number of coils decreases, slot pitch increases, tooth becomes mechanically strong and efficiency increases, quantity of insulation in the slot increases, heat dissipation reduces, temperature increases and hence the efficiency decreases.

It is clear that not much advantage is gained by the use of either too a less or more number of slots. As a preliminary value, the number of slots can be selected by considering the slot pitch. The slot pitch can assumed to be between (2.5 and 3.5) cm. (This range is applicable to only to medium capacity machines and it can be more or less for other capacity machines).

The selection of the number of slots must also be based on the type of winding used, quality of commutation, flux pulsation etc.

When the number of slot per pole is a whole number, the number slots embraced by each pole will be the same for all positions of armature. However, the number teeth per pole will not be same.

This causes a variation in reluctance of the air gap and the flux in the air gap will pulsate. Pulsations of the flux in the air gap produce iron losses in the pole shoe and give rise to magnetic noises. On the other hand, when the slots per pole is equal to a whole number plus half the reluctance of the flux path per pole pair remains constant for all positions of the armature, and there will be no pulsations or oscillations of the flux in the air gap.

To avoid pulsations and oscillations of the flux in the air gap, the number of slots per pole should be a whole number plus half. When this is not possible or advisable for other reasons, the number of slots per pole arc should an integer.

2.9.Design of commutator and brushes

The Commutator is an assembly of Commutator segments or bars tapered in section. The segments made of hard drawn copper are insulated from each other by mica or micanite, the usual thickness of which is about 0.8 mm. The number of commutator segments is equal to the number of active armature coils.

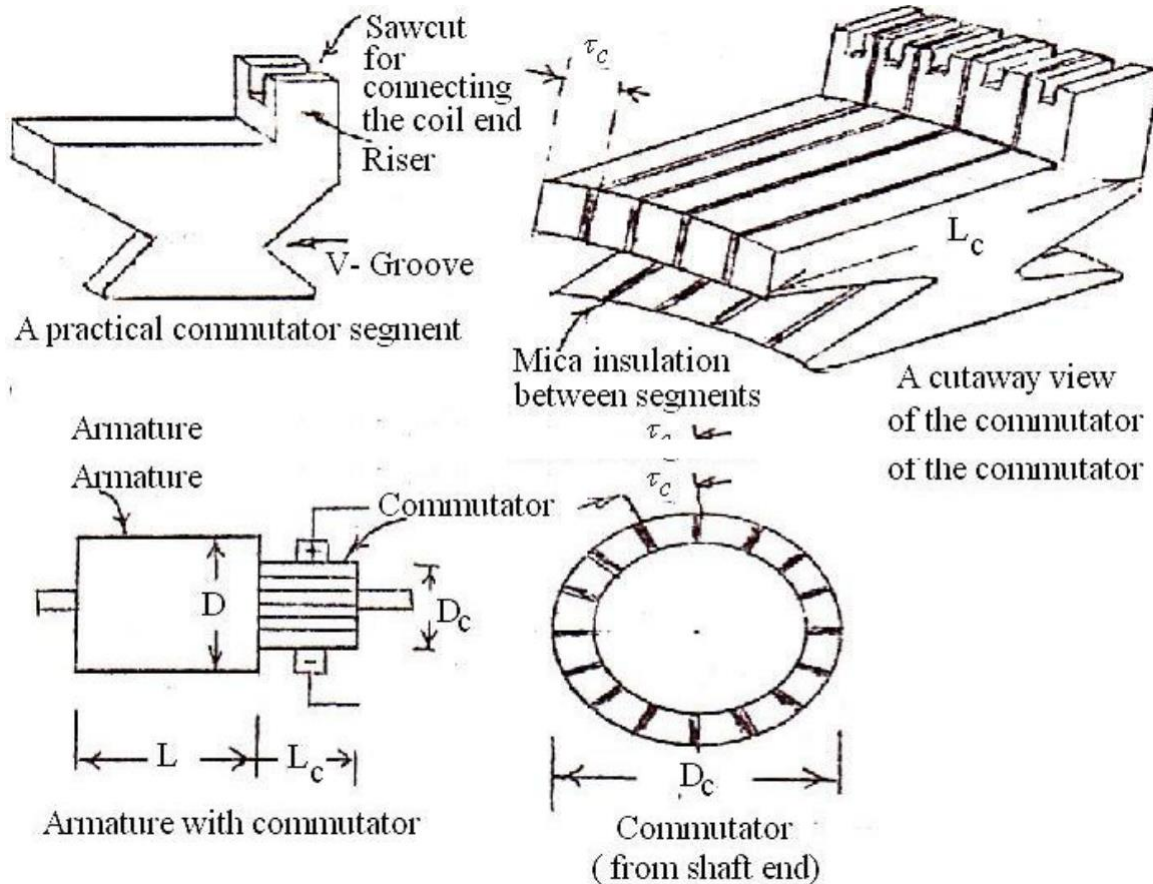

The diameter of the commutator will generally be about (60 to 80)% of the armature diameter. Lesser values are used for high capacity machines and higher values for low capacity machines.

Higher values of commutator peripheral velocity are to be avoided as it leads to lesser commutation time dt , increased reactance voltage — and sparking commutation.

The commutator peripheral velocity $v_c = \pi D C N / 60$ should not as far as possible be more than about 15 m/s. (Peripheral velocity of 30 m/s is also being used in practice but should be avoided whenever possible.)

The commutator segment pitch $\tau_c = (\text{outside width of one segment} + \text{mica insulation between segments}) = \pi D C / \text{Number of segments}$ should not be less than 4 mm. (This minimum segment pitch is due to 3.2 mm of copper + 0.8 mm of mica insulation between segments.) The outer surface width of commutator segment lies between 4 and 20 mm in practice.

The axial length of the commutator depends on the space required

- by the brushes with brush boxes
- for the staggering of brushes
- for the margin between the end of commutator and brush and

EE8002 DESIGN OF ELECTRICAL APPARATUS 4) for the margin between the brush and riser and width of riser.

If there are n_b brushes / brush arm or spindle or holder, placed one beside the other on the commutator surface, then the length of the commutator $LC = (\text{width of the brush } w_b + \text{brush box thickness } 0.5 \text{ cm}) \text{ number of brushes / spindle} + \text{end clearance } 2 \text{ to } 4 \text{ cm} + \text{clearance for risers } 2 \text{ to } 4 \text{ cm} + \text{clearance for staggering of brushes } 2 \text{ to } 4 \text{ cm}.$

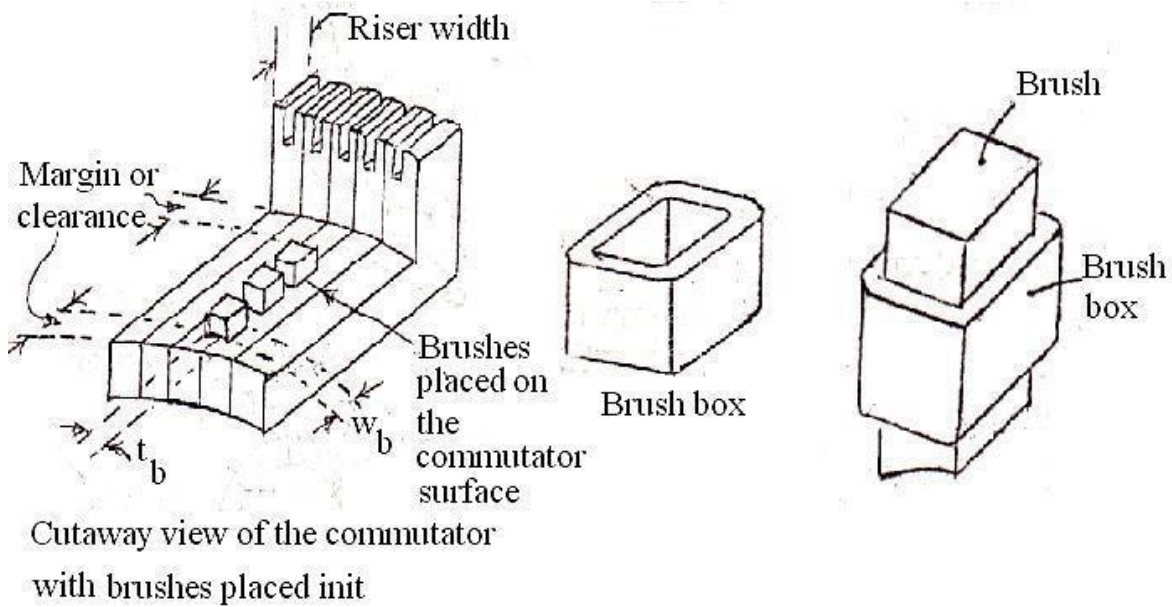

If the length of the commutator (as calculated from the above expression) leads to small dissipating surface $\pi DC LC$, then the commutator length must be increased so that the temperature rise of the commutator does not exceed a permissible value say 550°C .

The temperature rise of the commutator can be calculated by using the following empirical formula.

The different losses that are responsible for the temperature rise of the commutator are

- Brush contact loss and
- Brush frictional loss.

Brush contact loss = voltage drop / brush set $\times I_a$

The voltage drop / brush set depend on the brush material – Carbon, graphite, electro graphite or metalized graphite. The voltage drop / brush set can be taken as 2.0 V for carbon brushes. Brush frictional loss (due to all the brush arms)

frictional torque in Nm \times angular velocity

frictional force in Newton \times distance in meter $\times 2 \pi N/60$

$$9.81 \mu P_b A_{ball} \times DC / 2 \times 2\pi N / 60$$

$$9.81 \mu P_b A_{ball} v_C$$

where μ = coefficient of friction and depends on the brush material. Lies between 0.22 and 0.27 for carbon brushes

P_b = Brush pressure in kg / m² and lies between 1000 and

1500 A_{ball} = Area of the brushes of all the brush arms in m²

$A_b \times$ number of brush arms

$A_b \times$ number of poles in case of lap winding

$A_b \times 2$ or P in case of wave winding

A_b = Cross-sectional area of the brush / brush

arm **Brush Details**

Since the brushes of each brush arm collect the current from two parallel paths, current collected by each brush arm is $2 I_a$ and the cross-sectional area of the brush or brush arm or holder or spindle

$A_b = \frac{2 I_a}{\delta_p} \text{ cm}^2$. The current density δ_p depends on the brush material and can be assumed between 5.5 and 6.5 A / cm² for carbon.

In order to ensure a continuous supply of power and cost of replacement of damaged or worn out brushes is cheaper, a number of subdivided brushes are used instead of one single brush. Thus if

tb is the thickness of the brush ii) wb is the width of the brush and

nb is the number of sub divided brushes

then $A_b = tbwb nb$

As the number of adjacent coils of the same or different slots that are simultaneously undergoing commutation increases, the brush width and time of commutation also increases at the same rate and therefore the reactance voltage (the basic cause of sparking commutation) becomes independent of brush width.

With only one coil undergoing commutation and width of the brush equal to one segment width, the reactance voltage and hence the sparking increases as the slot width decreases. Hence the brush width is made to cover more than one segment. If the brush is too wide, then those coils which are away from the commutating pole zone or coils not coming under the influence of inter pole flux and undergoing commutation leads to sparking commutation.

Hence brush width greater than the commutating zone width is not advisable under any circumstances. Since the commutating pole zone lies between (9 and 15)% of the pole pitch,

15% of the commutator circumference can be considered as the maximum width of the brush.

DESIGN OF ELECTRICAL APPARATUS It has been found that the brush width should not be more than 5 segments in machines less than 50 kW and 4 segments in machines more than 50 kW.

The number of brushes / spindle can be found out by assuming a standard brush width or a maximum current / sub divided brush.

Standard brush width can be 1.6, 2.2 or 3.2 cm

Current/subdivided brush should not be more than 70A

2.10. Brush materials and their properties:

Material	Peripheral velocity m/s	Current density in A/cm ²	Voltage drop per brush set in volts	Coefficient of friction
Normal carbon	5 to 15	5.5 to 6.5	2.0	0.22 to 0.27
Soft graphite	10 to 25	9.0 to 9.5	1.6	0.12
Metalized graphite (copper carbon mixture)	5 to 15	15 to 16	0.24 to 0.35	0.16
Electro graphite (Graphitized by heating)	5 to 15	8.5 to 9.0	1.7 to 1.8	0.22

Problems:

EX.1. A 500kW, 500V, 375 rpm, 8 pole dc generator has an armature diameter of 110 cm and the number of armature conductor is 896. Calculate the diameter of the commutator, length of the commutator, number of brushes per spindle, commutator losses and temperature rise of the commutator. Assume single turn coils.

Diameter of the commutator $DC = (0.6 \text{ to } 0.8) D = 0.7 \times 110 = 77\text{cm}$

Length of the commutator $LC = (\text{width of the brush } W_b + \text{brush box thickness } 0.5 \text{ cm})$
 number of brushes / spindle $nb + \text{end clearance } 2 \text{ to } 4 \text{ cm} + \text{clearance for risers } 2 \text{ to } 4 \text{ cm} +$
 clearance for staggering of brushes 2 to 4 cm.

EX.2. A 600 kW, 6 pole lap connected D.C. generator with commutating poles running at 1200 rpm develops 230V on open circuit and 250V on full load. Find the diameter of the commutator, average volt / conductor, the number of commutator segments, length of commutator and brush contact loss. Take Armature diameter = 56 cm, number of armature conductors = 300, number of slots = 75, brush contact drop = 2.3 V, number of carbon brushes = 8 each 3.2 cm x 2.5 cm. The voltage between commutator segments should not exceed 15V.

2.11. Performance prediction using design values.

Based on the design data of the stator and rotor of DC Machine, performance of the machine has to be evaluated. The parameters for performance evaluation are

Iron losses,
No load current,
No load power factor,
Leakage reactance etc.

Based on the values of these parameters design values of stator and rotor can be justified.

Iron losses: Iron losses are occurring in all the iron parts due to the varying magnetic field of the machine. Iron loss has two components, hysteresis and eddy current losses occurring in the iron parts depend upon the frequency of the applied voltage. The frequency of the induced voltage in rotor is equal to the slip frequency which is very low and hence the iron losses occurring in the rotor is negligibly small. Hence the iron losses occurring in the induction motor is mainly due to the losses in the stator alone. Iron losses occurring in the stator can be computed as given below.

Problems:

A 150hp, 500V, 6pole, 450rpm, dc shunt motor has the following data. Armature diameter = 54cm, length of armature core = 24.5cm, average flux density in the air gap = 0.55T, number of ducts = 2, width of each duct = 1.0cm, stacking factor = 0.92. Obtain the number of armature slots and work the details of a suitable armature winding. Also determine the dimensions of the slot. The flux density in the tooth at one third height from the root should not exceed 2.1T.

For a preliminary design of a 1500kW, 275V, 300rpm, dc shunt generator determine the number of poles, armature diameter and core length, number of slots and number of conductors per slot. Assume: Average flux density over the pole arc as 0.85T, Output coefficient 276, Efficiency 0.91. Slot loading should not exceed 1500A.

Calculate the armature diameter and core length for a 7.5kW, 4pole, 1000rpm, and 220V shunt motor. Assume: Full load efficiency = 0.83, field current is 2.5% of rated current. The maximum efficiency occurs at full load.

For a preliminary design of a 50hp, 230V, 1400 rpm dc motor, calculate the armature diameter and core length, number of poles and peripheral speed. Assume specific magnetic loading 0.5T, specific electric loading 25000 ampere- conductors per meter, efficiency 0.9.

Determine the diameter and length of the armature core for a 55kW, 110V, 1000rpm, and 4pole dc shunt generator. Assume: Specific magnetic loading 0.5T, Specific electric loading 13000 ampere – turns, Pole arc 70% of pole pitch and length of core about 1.1 times the pole arc, Allow 10A for field current and a voltage drop of 4V for the armature circuit.

Determine also the number of armature conductors and slots. A design is required for a 50kW,4pole,600rpm, and 220V dc shunt generator. The average flux density in the air gap and specific electric loading are respectively 0.57T and 30000 ampere- conductors per metre. Calculate suitable dimensions of armature core to lead to a square pole face. Assume that full load armature drop is 3% of the rated voltage and the field current is 1% of rated full load current. Ratio pole arc to pole pitch is 0.67.

Determine the main dimensions of the armature core, number of conductors, and commutator segments for a 350kW, 500V, 450 rpm, 6pole shunt generator assuming a square pole face with pole arc 70% of the pole pitch. Assume the mean flux density to be 0.7T and ampere conductors per cm to be 280.

Determine the number of poles, armature diameter and core length for the preliminary design of a 500kW, 400V, 600 rpm, dc shunt generator assuming an average flux density in the air gap of 0.7 T and specific electric loading of 38400 ampere- conductors per metre. Assume core length/ pole arc = 1.1. Apply suitable checks

QUESTION BANK

Unit-II D.C. MACHINES

1. Define gap expansion factor and give the equation for it.

The ratio of reluctance of flux path when armature with slot to reluctance of flux path when armature without slot.

$$K_{gs} = Y_s / (Y_s - K_{cs} W_s) > 1 \quad \text{slots}$$

$$K_{gd} = L / (L - K_{cd} n_d W_d) > 1 \quad \text{ducts}$$

What is the advantage of large number of poles?

weight of iron parts decreases
weight of copper part decreases
length of commutator reduces
overall length of machine reduces
Distortion of field form becomes less at full load condition.

Why the interlope is used in a dc machine.

To reduce the armature reaction.
To improve commutation.

Why the brush is made up of carbon?

To reduce spark between brush and commutator.
To conduct electric current.
To avoid wear and tear due to rubbing.

Define leakage coefficient and give the equation for it.

The ratio of total flux per pole to the useful flux per pole is called leakage coefficient or leakage factor.

$$C_1 = \Phi_p / \Phi = 1.08 \text{ to } 1.25$$

6. Define iron stacking factor.

It is defined as the ratio of net length of armature to the gross length of the armature.

$$K_i = 0.9 \text{ to } 0.96$$

7. What is meant by peripheral speed of armature?

The distance travel by the armature per unit time is called as peripheral speed.

$$V_a = \pi D n \text{ m/sec}$$

n = speed in r.p.s.

D = diameter of armature in m

8. Define armature reaction.

The flux produced due to current flow to the armature conductors opposes the main flux. This phenomenon is known as armature reaction.

What are the effects of armature reaction?

Reduction in emf
Increase in iron loss
Sparking and ring fire
Delayed commutation

What does staggering of brushes mean?

Brushes are provided in different planes instead of same plane at the surface of commutator to avoid the formation of ridges. This is called staggering.

Mention the different modes of operation of a D.C. Machine.

Generator mode: In this mode, the machine is driven by a prime mover with mechanical power converted into electrical power.

Motor mode: The machine drives a mechanical load with the electrical power supplied converted into mechanical power.

Brake mode: The machine works as a generator and the electrical power developed is either pumped back to the supply as in regenerative braking.

State use of a yoke in a D.C. machine.

The yoke serves as a path for flux in D.C. machine and it also serve as an enclosure for the machine.

What purpose is served by the pole shoe in a D.C. machine?

The pole shoes serve the following purposes:

They spread out the flux in the air gap.

Since they are of larger cross section, the reluctance of the magnetic path is reduced.

They support the field coils.

Mention the factors that affect the size of rotating machines.

The factors that affect the size of rotating machines are:

Speed and

Output co-efficient

What is known as output equation?

The output of a machine can be expressed in terms of its main dimensions, specific magnetic and electric loadings and speed. The equation describing this relationship is known as output equation.

Derive the output equation of a D.C. machine.

Power developed by armature in KW,

$$P_a = \text{Generated emf} * \text{armature current} * 10^{-3}$$

$$P_a = (\pi D L B_{av}) (\pi D ac) n * 10^{-3}$$

$$= (\pi^2 B_{av} ac * 10^{-3}) D^2 L n$$

$$= C_0 D^2 L n$$

where $C_0 = \pi^2 B_{av} ac * 10^{-3}$

D = armature diameter, m

L = stator core length, m

n = speed, rps

C₀ is the output co-efficient

How is specific magnetic loading determined?

The specific magnetic loading is determined by

Maximum flux density in iron parts of machine

Magnetizing current and core losses

Calculate the output co-efficient of a dc shunt generator from the given

data. $B_g = 0.89 \text{ Wb/m}^2$; $ac = 3200 \text{ amp.cond/m}$; $\Psi = 0.66$.

$$\text{Output co-efficient, } C_0 = \pi^2 \Psi B_g ac * 10^{-3}$$

$$\pi^2 * 0.66 * 0.89 * 3200 * 10^{-3}$$

$$185.5 \text{ KW / m}^3 - \text{rps.}$$

What is the range of specific magnetic loading in D.C. Machine?

The usual range of specific magnetic loading in dc machine is 0.4 to 0.8 Wb/m².

What are the factors to be considered for the selection of number of poles in dc machine?

The factors to be considered for the selection of number of poles in dc machine are:

Frequency

Weight of iron parts

Weight of copper

Length of commutator

Lab our charges
Flash over and distortion of field mmf

What are the quantities that are affected by the number of poles?

Weight of iron and copper, length of commutator and dimension of brushes are the quantities affected by the number of poles.

21. List the disadvantages of large number of poles.

The large number of poles results in increases of the following:

Frequency of flux reversals
Labour charges
Possibility of flash over between brush arms

Mention guiding factors for the selection of number of poles.

The frequency should lie between 25 to 50 Hz.
The value of current per parallel path is limited to 200A, thus the current per brush arm should not be more than 400A.
The armature mmf should not be too large. The mmf per pole should be in the range 5000 to 12,500 AT.
Choose the largest value of poles which satisfies the above three conditions.

What are the losses at the commutator surface?

The losses at the commutator surface are the brush contact losses and brush friction losses.

Write down the expression for brush friction losses.

The brush friction loss is given as $P_{bf} = \mu P_b A_B V_c$

Where μ = co-efficient of friction
 P_b = brush contact pressure
 A_B = total contact area of all brushes, m^2
 V_c = Peripheral speed of commutator, m/s

What are the advantages of carbon brushes?

They lubricate and polish the commutator
If sparking occurs, they damage the commutator less than with the copper brushes.
They provide good commutation.

What is the height occupied by series field coil in a field pole?

In a field pole of compound machine, approximately 80% of the height is occupied by shunt field coil and 20% by the series field coil.

27. How the Ampere turns of the series field coil is estimated?

In compound machines, the ampere turns to be developed by the series field coil are estimated as 15 to 25% of full load armature mmf. In series machines, the ampere turns to be developed by the series field coil are estimated as 1.15 to 1.25 times of full load armature mmf.

Mention the factors to be considered for the design of shunt field coils.

Mmf per pole and flux density
Loss dissipated from the surface of field coil
Resistance of the field coil
Current density in the field conductors

State the use of interpoles.

The interpoles are used in D.C. machines to neutralize the cross magnetizing armature mmf at the interpolar axis and to neutralize the reactance voltage in the coil undergoing commutation.

State the relation between the armature and the commutator diameter for various ratings of D.C. machines. The diameter of the commutator is chosen as 60 to 80% of armature diameter. The limiting factor is the peripheral speed. The typical choice of commutator diameter for various voltage ratings are listed here:

Voltage range (Volts)	Commutator diameter (D _c)
350 to 700	0.62 D
200 to 250	0.68 D
100 to 125	0.75 D

Where D is the armature diameter.

31. Why is the value of magnetizing current not a series design consideration in D.C.machines?

The value of magnetizing current is not a series design consideration in D.C.machines as there is ample space on salient poles to accommodate the required number of field turns.

32. What should be the peripheral speed of the commutator?

The commutator peripheral speed is generally kept below 15 m/s. Higher peripheral speeds upto 30m/s are used but should be avoided wherever possible. The higher commutator peripheral speeds generally lead to commutation difficulties.

How is the length of commutator designed?

The length of the commutator is designed based upon the space required by the brushes and upon the surface required to dissipate the heat generated by the commutator losses.

Length of commutator, $L_c = n_b (W_b + C_b) + C_1 + C_2$

Where n_b = number of brushes per spindle

W_b = width of each brush

C_b = clearance between the brushes

C_1 = clearance allowed for staggering the brushes

C_2 = clearance for allowing the end play

34. What is the purpose of slot insulation?

The conductors are placed on the slots in the armature. When the armature rotates, the insulation of the conductors may damage due to vibrations. This may lead to a short circuit with armature core if the slots are not insulated.

State any three conditions in deciding the choice of number of slots for a large D.C.machine.

The slot loading should be less than 1500 ampere conductors.

The number of slots per pole should be greater than or equal to 9 to avoid sparking.

The slot pitch should lie between 25 to 35 mm.

What are the factors that influence the choice of commutator diameter?

Peripheral speed

The peripheral voltage gradient should be limited to 3V/mm

Number of coils in the armature

What type of copper is used for commutator segment?

The commutator segments are made of hard drawn copper or silver copper (0.05% silver)

What are the materials used for brushes in D.C.machine?

Natural graphite

Hard carbon

Electro graphite

Metal graphite

What are the points to be considered while fixing up the dimensions of the slot?

Excessive flux density

Flux pulsations

Eddy current loss in conductors

Reactance voltage

Mechanical difficulties

Mention the factors that govern the choice of number of armature slots in a d.C.machine.

Slot pitch

Slot loading
Commutation
Suitability for winding
Flux pulsations

What is back pitch?

The distance between top and bottom coil sides of a coil measured around the back of the armature is called the back pitch. The back pitch is measured in terms of coil sides.

When are the pulsations and oscillations of air gap flux reduced to minimum?

The pulsations and oscillations of air gap flux reduced to minimum when,
The number of slots under the pole shoe is equal an integer plus $\frac{1}{2}$.
The number of slots per pole is equal to an integer plus $\frac{1}{2}$.

What factor decides the minimum number of armature coils?

The maximum voltage between adjacent commutator segments decides the minimum number of coils.

Explain how depth of armature core for a D.C. machine is determined.

Let $\phi = \text{Flux/pole}$; $L_i = \text{Net iron length of armature}$;

$\phi_c = \text{Flux in armature core}$; $d_c = \text{depth of armature core}$;

$B_c = \text{Flux density in the armature core}$; $A_c = \text{Area of cross-section of armature core}$.

Now $\phi_c = \phi/2$ and $A_c = \phi_c / B_c$

Also $A_c = L_i d_c$ $d_c = \phi / 2 L_i B_c$

List the characteristics of wave winding.

The number of parallel paths is two.

The current through a conductor is $I_a / 2$, where I_a is the armature current.

The winding will have less number of conductors with larger area of cross-section

The emf induced in both the parallel paths will be always equal

What are the applications of D.C. special motors?

The D.C. special motors are used in closed loop control system as power actuators and to provide linear motions. They are also used as clutches, couplings, eddy current brakes, very high speed drives, etc.,.

47. Why square pole is preferred?

If the cross-section of the pole body is square then the length of the mean turn of field winding is minimum. Hence to reduce the copper requirement a square cross-section is preferred for the poles of D.C. machine.

48. Distinguish between lap and wave windings used in D.C. machine.

The lap and wave windings primarily differ from each other in the following two factors:
The number of circuits between the positive and negative brushes, i.e., number of parallel paths.
The manner in which the coil ends are connected to the commutator Segments.

What are dummy coils?

The coils which are placed in armature slot for mechanical balance but not connected electrically to the armature winding are called dummy coils.

What are the different types of commutation?

The different types of commutation are:

Resistance commutation
Retarded commutation
Accelerated commutation
Sinusoidal commutation

UNIT III TRANSFORMERS

Output Equations – Main Dimensions - KVA output for single and three phase transformers – Window space factor – Overall dimensions – Operating characteristics – Regulation – No load current – Temperature rise in Transformers – Design of Tank - Methods of cooling of Transformers.

3.1. Design features of power and distribution type transformers:**Power transformer**

Load on the transformer will be at or near the full load through out the period of operation. When the load is less, the transformer, which is in parallel with other transformers, may be put out of service. Generally designed to achieve maximum efficiency at or near the full load. Therefore iron loss is made equal to full load copper loss by using a higher value of flux density. In other words, power transformers are generally designed for a higher value of flux density.

Necessity of voltage regulation does not arise .The voltage variation is obtained by the help of tap changers provided generally on the high voltage side. Generally Power transformers are deliberately designed for a higher value of leakage reactance, so that the short-circuit current, effect of mechanical force and hence the damage is less.

Distribution transformer

Load on the transformer does not remain constant but varies instant to instant over 24 hours a day. Generally designed for maximum efficiency at about half full load. In order that the all day efficiency is high, iron loss is made less by selecting a lesser value of flux density. In other words distribution transformers are generally designed for a lesser value of flux density. Since the distributed transformers are located in the vicinity of the load, voltage regulation is an important factor.

Generally the distribution transformers are not equipped with tap changers to maintain a constant voltage as it increases the cost, maintenance charges etc., Thus the distribution transformers are designed to have a low value of inherent regulation by keeping down the value of leakage reactance.

3.2. Output Equations**Single phase core type transformer**

$$\text{Rating of the transformer in kVA} = V_1 I_1 \times 10^{-3} = E_1 I_1 \times 10^{-3} = 4.44 \phi_m f T_1 \times I_1 \times 10^{-3} \text{----(1)}$$

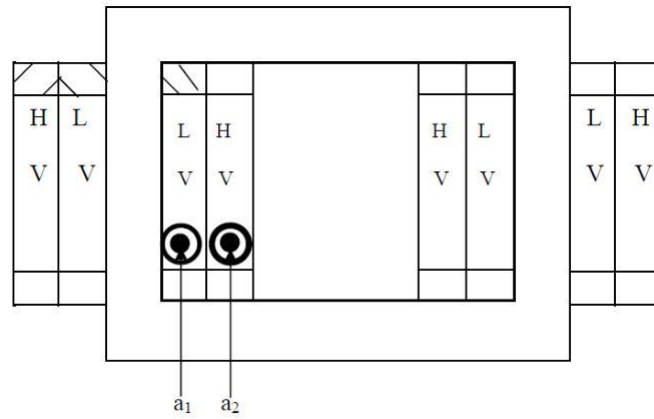

Note:Each leg carries half of the LV and HV turns
 Area of copper in the window

Therefore $\dots\dots(2)$
 After substituting (2) in (1),
 $\dots\dots\dots$

Single phase shell type transformer

$$\begin{aligned} \text{Rating of the transformer in kVA} &= V_1 I_1 \times 10^{-3} = E_1 I_1 \times 10^{-3} \\ &= 4.44 \phi_m f T_1 \times I_1 \times 10^{-3} \dots(1) \end{aligned}$$

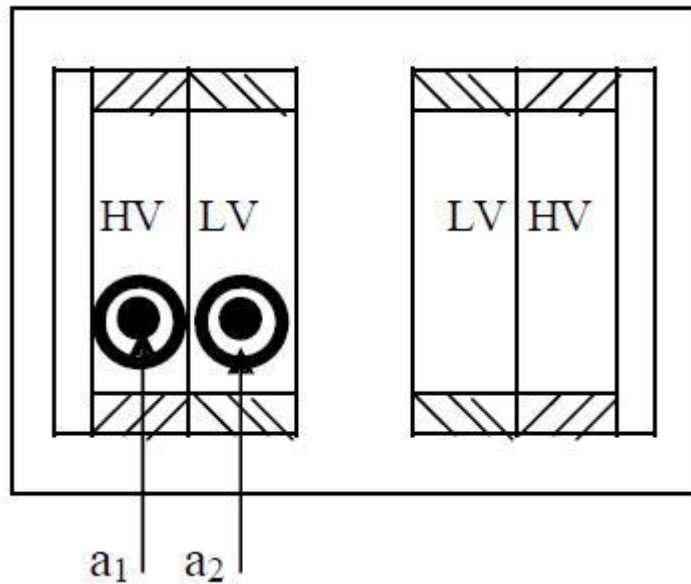

EE8002 DESIGN OF ELECTRICAL APPARATUS **Note** : Since there are two windows, it is sufficient to design one of the two windows as

both the windows are symmetrical. Since the LV and HV windings are placed on the central leg, each window accommodates T1 and T2 turns of both primary and secondary windings.

Area of copper in the window

Therefore _____(2)

After substituting (2) in (1),

Three phase core type transformer

$$\text{Rating of the transformer in kVA} = V_1 I_1 \times 10^{-3} = E_1 I_1 \times 10^{-3} = 3 \times 4.44 \phi_m f T_1 \times I_1 \times 10^{-3} \dots (1)$$

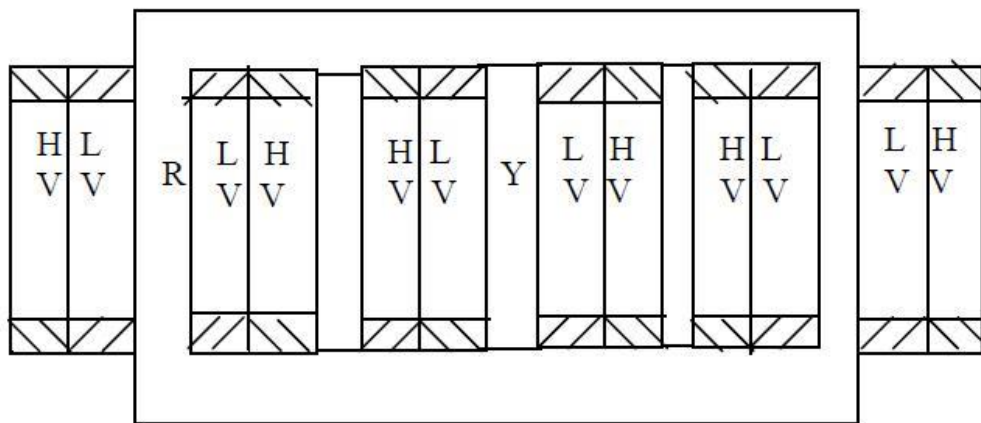

Note: Since there are two windows, it is sufficient to design one of the two windows, as both the windows are symmetrical. Since each leg carries the LV & HV windings of one phase, each window carry the LV & HV windings of two phases

Since each window carries the windings of two phases, area of copper in the window, say due to R & Y phases

Therefore _____(2)

After substituting (2) in (1)

3.3. Main Dimensions

KVA output for single and three phase transformers

Single phase core type transformer

$$\text{Rating of the transformer in kVA} = V_1 I_1 \times 10^{-3} = E_1 I_1 \times 10^{-3} = 4.44 \phi_m f T_1 \times I_1 \times 10^{-3} \dots (1)$$

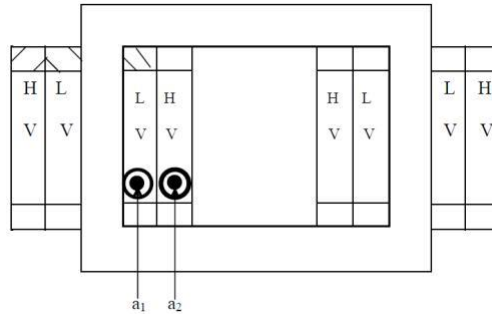

Note: Each leg carries half of the LV and HV turns

Area of copper in the window

Therefore -----(2)

After substituting (2) in (1),

Single phase shell type transformer

$$\begin{aligned} \text{Rating of the transformer in kVA} &= V_1 I_1 \times 10^{-3} = E_1 I_1 \times 10^{-3} \\ &= 4.44 \phi_m f T_1 \times I_1 \times 10^{-3} \dots (1) \end{aligned}$$

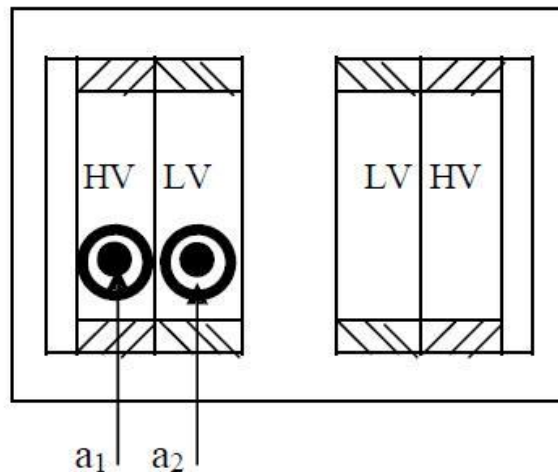

EE8002 DESIGN OF ELECTRICAL APPARATUS **Note** : Since there are two windows, it is sufficient to design one of the two windows as

both the windows are symmetrical. Since the LV and HV windings are placed on the central leg, each window accommodates T1 and T2 turns of both primary and secondary windings.

Area of copper in the window

Therefore _____(2)

After substituting (2) in (1),

Three phase core type transformer

$$\text{Rating of the transformer in kVA} = V_1 I_1 \times 10^{-3} = E_1 I_1 \times 10^{-3} = 3 \times 4.44 \phi_m f T_1 \times I_1 \times 10^{-3} \dots (1)$$

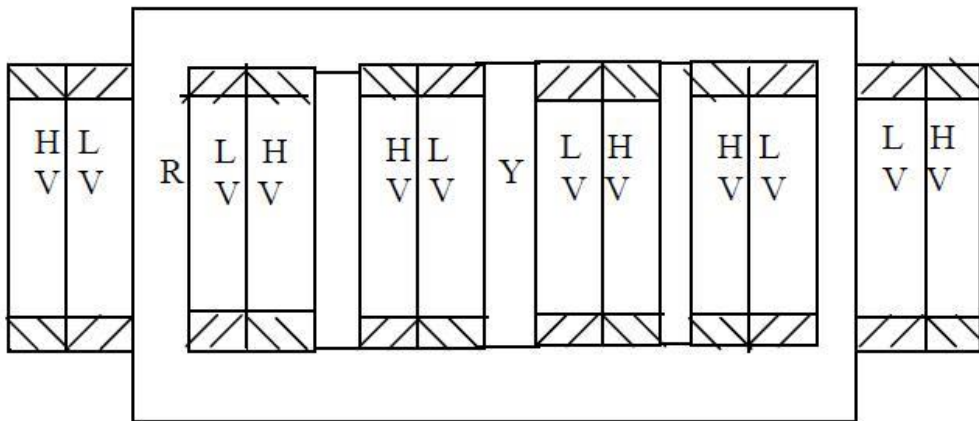

Note: Since there are two windows, it is sufficient to design one of the two windows, as both the windows are symmetrical. Since each leg carries the LV & HV windings of one phase, each window carry the LV & HV windings of two phases

Since each window carries the windings of two phases, area of copper in the window, say due to R & Y phases

Therefore _____(2)

After substituting (2) in (1)

3.4. Window space factor K_w

Window space factor is defined as the ratio of copper area in the window to the area of the window. That is

For a given window area, as the voltage rating of the transformer increases, quantity of insulation in the window increases, area of copper reduces. Thus the window space factor reduces as the voltage increases. A value for K_w can be calculated by the following empirical formula.

3.5. Overall dimensions

The main dimensions of the transformer are

Height of window (H_w)

Width of the window (W_w)

The other important dimensions of the transformer are

width of largest stamping (a)

diameter of circumscribing circle

As the iron area of the leg A_i and the window area $A_w = (\text{height of the window } H_w \times \text{Width of the window } W_w)$ increases the size of the transformer also increases. The size of the transformer increases as the output of the transformer increases.

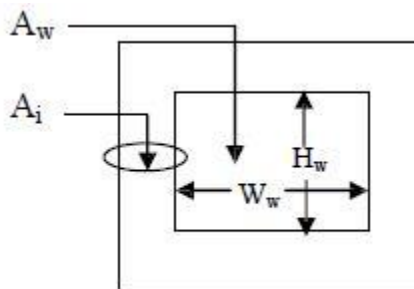

Output-kVA

Voltage- V_1/V_2 with or without tap changers and tapings

Frequency- f Hz

Number of phases – One or three

Rating – Continuous or short time

Cooling – Natural or forced

Type – Core or shell, power or distribution

Type of winding connection in case of 3 phase transformers – star-star, star-delta, delta-delta, delta-star with or without grounded neutral

Efficiency, per unit impedance, location (i.e., indoor, pole or platform mounting etc.), temperature rise etc.,

3.6. Operating characteristics

3.7. Regulation

$$\text{Percentage regulation} = \frac{I_1 R_p \cos\phi + I_1 X_p \sin\phi}{V_1} \times 100$$

3.8. No load current

The phasor sum of the magnetizing current (Im) and the loss component of current (Ic) ; Im is calculated using the MMF/m required for the core and yoke and their respective length of flux path. Ic is determined using the iron loss curve of the material used for the core and yoke and the flux density employed and their weight.

The no-load current I0 is the vectorial sum of the magnetizing current Im and core loss or working component current Ic. [Function of Im is to produce flux φm in the magnetic circuit and the function of Ic is to satisfy the no load losses of the transformer]. Thus,

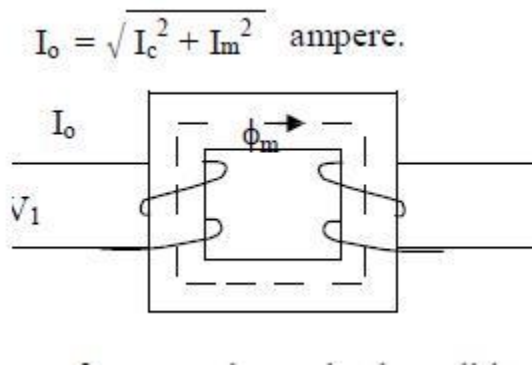

Transformer under no-load condition

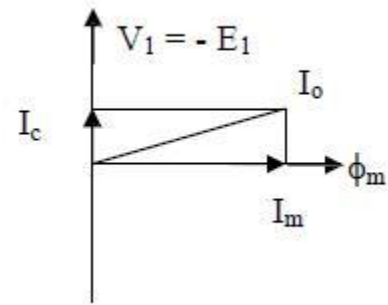

Vector diagram of Transformer under no-load condition

No load input to the transformer = $V_1 I_0 \cos\phi_0$ $V_1 I_c =$ No load losses as the output is zero and input = output + losses.

3.9. Temperature rise in Transformers

Losses dissipated in transformers in the core and windings get converted into thermal energy and cause heating of the corresponding transformer parts. The heat dissipation occurs as follows: i) from the internal heated parts to the outer surface in contact with oil by conduction ii) from oil to the

convection.

Q = Power loss(heat produced), J/s or W

G = weight of the active material of the Machine, kg

h = specific heat, J/kg-°C

S = cooling surface area, m²

c = specific heat dissipation, W/ m² -°C

λ = cooling coefficient, m² -°C / W

θ_m = final steady temperature rise, °C

The temperature of the machine rises when it is supplying load. As the temperature rises, the heat is dissipated partly by conduction, partly by radiation and in most cases largely by air cooling. The temperature rise curve is exponential in nature. Assuming the theory of heating of homogeneous bodies ,

Heat developed = heat stored + heat dissipated

3.10. Design of Tank

Because of the losses in the transformer core and coil, the temperature of the core and coil increases. In small capacity transformers the surrounding air will be in a position to cool the transformer effectively and keeps the temperature rise well within the permissible limits. As the capacity of the transformer increases, the losses and the temperature rise increases. In order to keep the temperature rise within limits, air may have to be blown over the transformer. This is not advisable as the atmospheric air containing moisture, oil particles etc., may affect the insulation. To overcome the problem of atmospheric hazards, the transformer is placed in a steel tank filled with oil. The oil conducts the heat from core and coil to the tank walls. From the tank walls the heat goes dissipated to surrounding atmosphere due to radiation and convection. Further as the capacity of the transformer increases, the increased loss demands a higher dissipating area of the tank or a bigger sized tank. These calls for more space, more volume of oil and increases the cost and transportation problems. To overcome these difficulties, the dissipating area is to be increased by artificial means without increasing the size of the tank. The dissipating area can be increased by

fitting fins to the tank walls

fitting tubes to the tank and

using corrugated tank

using auxiliary radiator tanks

constructional difficulties, they are not much used now a days. The tanks with tubes are much used in practice. Tubes in more number of rows are to be avoided as the screening of the tank and tube surfaces decreases the dissipation. Hence, when more number of tubes are to be provided, a radiator attached with the tank is considered. For much larger sizes forced cooling is adopted.

Dimensions of the Tank

The dimensions of tank depends on the type and capacity of transformer, voltage rating and electrical clearance to be provided between the transformer and tank, clearance to accommodate the connections and taps, clearance for base and oil above the transformer etc.,. These clearances can assumed to be between

(30 and 60) cm in respect of tank height

(10 and 20) cm in respect of tank length and

(10 and 20) cm in respect of tank width or breadth.

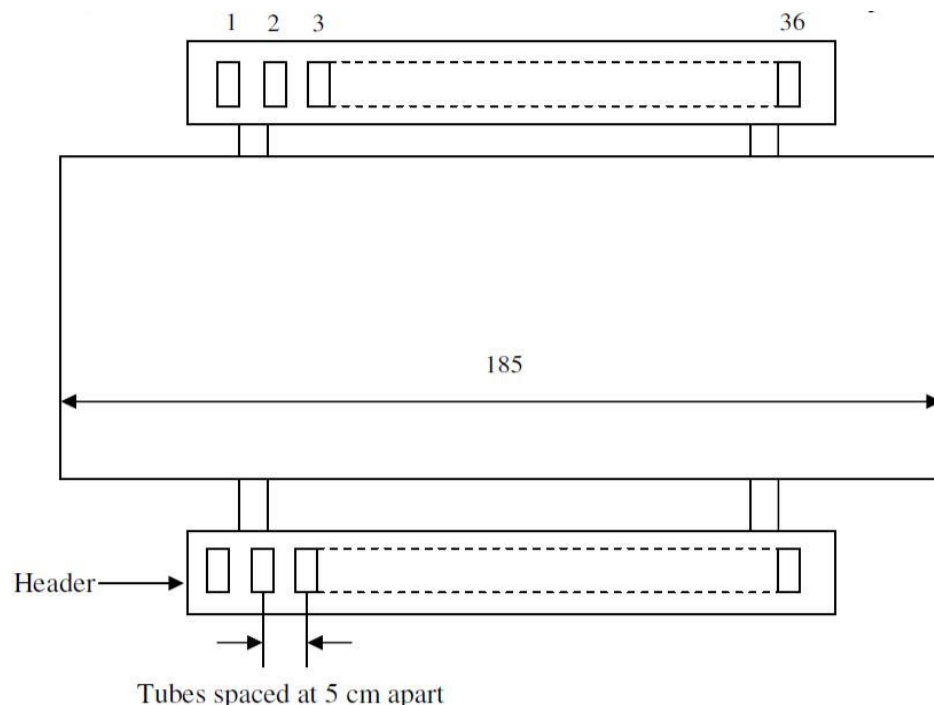

Tank height $H_t = [H_w + 2H_y \text{ or } 2a + \text{clearance (30 to 60) cm}]$ for single and three phase core, and single phase shell type transformers.

$[3(H_w + 2H_y \text{ or } 2a) + \text{clearance (30 to 60) cm}]$ for a three phase shell type transformer.

Tank length $L_t = [D + D_{ext} + \text{clearance (10 to 20) cm}]$ for single phase core type transformer = $[2D + D_{ext} + \text{clearance (10 to 20) cm}]$ for three phase core type transformer = $[4a + 2W_w + \text{clearance (10 to 20) cm}]$ for single and three phase shell type transformer.

transformers with a circular coil.

$[b + W_w + \text{clearance (10 to 20) cm}]$ for single and three phase core type transformers having rectangular coils.

$[b + 2W_w + \text{clearance (10 to 20) cm}]$ for single and three phase shell type transformers.

When the tank is placed on the ground, there will not be any heat dissipation from the bottom surface of the tank. Since the oil is not filled up to the brim of the tank, heat transfer from the oil to the top of the tank is less and heat dissipation from the top surface of the tank is almost negligible. Hence the effective surface area of the tank S_t from which heat is getting dissipated can assumed to be $2Ht (L_t + W_t) \text{ m}^2$.

Heat goes dissipated to the atmosphere from tank by radiation and convection. It has been found by experiment that 6.0W goes radiated per m^2 of plain surface per degree centigrade difference between tank and ambient air temperature and 6.5W goes dissipated by convection / m^2 of plain surface / degree centigrade difference in temperature between tank wall and ambient air. Thus a total of $12.5\text{W}/\text{m}^2/^\circ\text{C}$ goes dissipated to the surrounding. If is the temperature rise, then at final steady temperature condition, losses responsible for temperature rise is losses dissipated or transformer losses = $12.5 S_t$.

Number and dimensions of tubes

If the temperature rise of the tank wall is beyond a permissible value of about 50°C , then cooling tubes are to be added to reduce the temperature rise. Tubes can be arranged on all the sides in one or more number of rows. As number of rows increases, the dissipation will not proportionally increase. Hence the number of rows of tubes are to be limited. Generally the number of rows in practice will be less than four.

With the tubes connected to the tank, dissipation due to radiation from a part of the tank surface screened by the tubes is zero. However if the radiating surface of the tube, dissipating the heat is assumed to be equal to the screened surface of the tank, then tubes can assumed to be radiating no heat. Thus the full tank surface can assumed to be dissipating the heat due to both radiation and convection & can be taken as $12.5 S_t$ watts.

Because the oil when get heated up moves up and cold oil down, circulation of oil in the tubes will be more. Obviously, this circulation of oil increases the heat dissipation. Because of this siphoning action, it has been found that the convection from the tubes increase by about 35 to 40%.

Thus if the improvement is by 35%, then the dissipation in watts from all the tubes of area $A_t = 1.35 \times 6.5A_t = 8.78 A_t$.

Thus in case of a tank with tubes, at final steady temperature rise condition,

$$\text{Losses} = 12.5 S_t + 8.78 A_t$$

Round, rectangular or elliptical shaped tubes can be used. The mean length or height of the tubes is generally taken as about 90% of tank height.

In case of round tubes, 5 cm diameter tubes spaced at about 7.5cm (from centre to centre) are used. If d_t is the diameter of the tube, then dissipating area of each tube at $= p d_t \times 0.9H_t$. if n_t is the number of tubes, then $A_t = a_t n_t$.

Now a days rectangular tubes of different size spaced at convenient distances are being much used, as it provides a greater cooling surface for a smaller volume of oil. This is true in case of elliptical tubes also. The tubes can be arranged in any convenient way ensuring mechanical strength and aesthetic view.

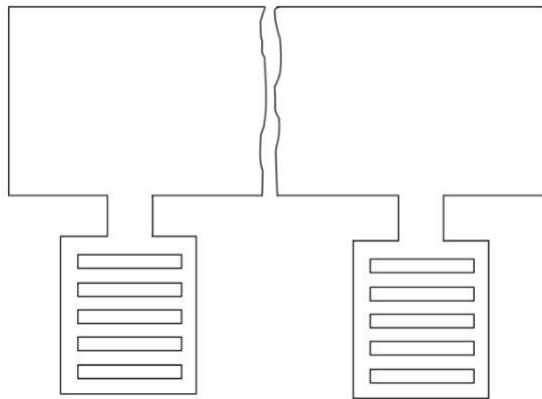

Different ways of tube arrangement (rectangular)

3.11. Methods of cooling of Transformers.

- Air natural
- Air blast
- Oil natural
- Oil natural – air forced
- Oil natural water forced
- Forced circulation of oil
- Oil forced – air natural
- Oil forced – air forced
- Oil forced – water forced

QUESTION BANK**Unit-III TRANSFORMERS****1. Define transformation ratio.**

It is defined as the ratio of secondary terminal voltage to primary terminal voltage.
It is denoted by k.

$$K = V_s / V_p = T_s / T_p = I_p / I_s$$

2. Name the types of transformer.

Based upon construction, the types are

Core type and
shell type transformer

Based on applications, the types are

Distribution transformers
Power transformers
Special transformers
Instrument transformers
Electronics transformers

Based on the type of connection, the types are

Single phase transformer
Three phase transformer

Based on the frequency range, the types are

Power frequency transformer
Audio frequency transformer
UHF transformers
Wide band transformers
Narrow band transformer
Pulse transformer

Based on the number of windings, the types are

Auto transformer
Two winding transformer

Define windows space factor or window area constant.

It is defined as the ratio of the area of copper in the window to the window area.

$$K_w = A_c / A_w < 1$$

A_c is the area of copper in m^2

A_w is the area of window in m^2

4. Define iron space factor.

It is defined as the ratio of gross core area to the area of the circumscribing circle.

$$K_{is} = A_{gi} / A_{ce} < 1$$

A_{gi} is the gross core area in m^2

A_{ce} is the area of circumscribing circle in m^2

What is a function of a transformer?

It increases or decreases the voltage at same frequency.

It transforms energy from one winding to other winding at constant frequency.

It is used in electronic circuits with rectifying units to convert ac to dc.

It provides isolation between electrical circuits.

What is the function of transformer oil?

It provides cooling.

It acts as insulation.

It protects the paper from dirt and moisture.

What is the cause of noise in transformer?

- Mechanical forces developed during working
- Loosening of stampings in the core
- Expansion and contraction of oil level

What are the properties of transformer oil?

- High dielectric strength
- High resistivity and density
- Low viscosity
- Low impurity
- Reasonable cost and flash point

Difference between core type and shell type transformer.

CORE TYPE	SHELL TYPE
Core is surrounded by the winding.	Winding is surrounded by the core.
Construction is simple.	Construction is difficult.
Repair is easy.	Repair is difficult.
High capacity machine.	Low capacity machine.

10. Difference between distribution and power transformer.

Distribution transformer	Power transformer
Power rating ≤ 200 KVA	Power rating > 200 KVA
Used for distribution purposes.	Used for transmission purposes.
Energy efficiency is good.	Power efficiency is good.
Regulation is low.	Regulation is high.

Mention the important characteristics desirable in transformer oil.

- Electric strength
- Resistance to emulsion
- Viscosity
- Purity
- Flash point
- Sludge formation

Why is transformer oil used as cooling medium?

When transformer oil is used as coolant, the heat dissipation by convection is 10 times more than the convection due to air specific heat dissipation by convection due to air = $8 \text{ W/ m}^2 - \text{C}$.

Specific heat dissipation by convection due to oil = $80 \text{ to } 100 \text{ W/ m}^2 - \text{C}$.

13. Mention the factors to be considered for selecting the cooling method of a transformer.

The choice of cooling method depends on KVA rating of transformer, size, application and the site condition where it has to be installed.

List the different methods of cooling of transformer.

- Air natural
- Air blast

- Oil natural
- Oil natural – air forced
- Oil natural water forced
- Forced circulation of oil
- Oil forced – air natural
- Oil forced – air forced
- Oil forced – water forced

Give an expression for the heating time constant of transformer. G h

The heating time constant of transformer is given as $T_h = \frac{G h}{S \lambda}$.

Where G is weight, h is specific heat, λ is the specific heat dissipation.

16. Why cooling tubes are provided?

Cooling tubes are provided to increase the heat dissipating area of the tank.

Give the expression for magnetizing current.

The magnetizing current is given by

Magnetizing VA / Kg * Weight of force

$$I_m = \frac{\text{Magnetizing VA / Kg * Weight of force}}{\text{Number of phases * Voltage/phase}}$$

Write the expression for temperature rise in plain walled tanks.

Total loss

The temperature rise = $\frac{\text{Specific heat dissipation * heat dissipating surface of the tank}}{12.5 S_t}$

$$= \frac{P_i + P_c}{12.5 S_t}$$

where P_i = iron loss ; P_c = copper loss ; S_t = Heat dissipating surface of the tank

19. Why plain walled tanks are not used for large output transformers?

The plain walled tanks are not used for large output transformers as they are not sufficient to dissipate losses. This is because volume and hence losses increase as cube of linear dimensions while the dissipating surface increases as the square of linear dimensions. Thus an increase in rating results in an increase in loss to be dissipated per unit area giving a higher temperature rise.

20. How is leakage reactance of winding estimated?

It is estimated by primarily estimating the distribution of leakage flux and the resulting flux leakages of the primary and the secondary windings. The distribution of the leakage flux depends upon the geometrical configuration of the coils and the neighboring iron masses and also on the permeability of the iron.

21. Define stacking factor and give its typical value.

Stacking factor = $\frac{\text{Area of cross-section of iron in core}}{\text{Area of cross-section of core including Insulation area}}$

Its typical value is 0.9.

22. Why stepped cores are used in transformers?

EE8002 DESIGN OF ELECTRICAL APPARATUS When stepped cores are used, the diameters of the circumscribing circle is minimum for a given area of the core, which helps in reducing the length of mean turn of the winding with consequent reduction in both cost of copper and copper loss.

What is the range of flux densities used in the design of a transformer?

When hot rolled silicon steel is used,
 $B_m = 1.1$ to 1.4 Wb / m^2 for distribution transformer
 $= 1.2$ to 1.5 Wb / m^2 for power transformer

When cold rolled silicon steel is used,
 $B_m = 1.5 \text{ Wb / m}^2$ for up to 132 KV transformer
 $= 1.6 \text{ Wb / m}^2$ for 132 KV to 275 KV transformer
 $= 1.7 \text{ Wb / m}^2$ for 275KV to 400 KV transformer

Name the factors to be considered to choose the type of winding for a core type transformer.

- Current density
- Short circuit current
- Surge voltage
- Impedance
- Temperature rise
- Transport facilities

Give typical values of core area factor for various types of transformers.

Core area factor (K_c) for various transformers:
 Square core $K_c = 0.45$
 Cruciform core $K_c = 0.56$
 Three stepped core $K_c = 0.6$
 Four stepped core $K_c = 0.62$

List the assumptions made for calculation of leakage flux and leakage reactance.

- The primary and secondary windings have an equal axial length
- The flux paths are parallel to the windings along the axial height
- Primary winding mmf is equal to secondary winding mmf
- Half of the leakage flux in the duct links with each winding
- The length of the mean turn of the windings are equal
- The reluctance of flux path through yoke is negligible

Define copper space factor.

For a transformer, it is the ratio of conductor area and window area.

$$\text{Copper space factor} = \frac{\text{Conductor area}}{\text{Window area}}$$

Name the various types of cross section used for core type transformer.

- Square
- Rectangle
- Cruciform and
- Multi stepped cores

What is window space factor?

The window space factor is defined as the ratio of copper area in window to total window area. Copper area in window

$$\text{Window space factor} = \frac{\text{Copper area in window}}{\text{Total Window area}}$$

30. How the area of window is calculated?

Area of the window (A_w) = Height of window (H_w) * Width of window (W_w).

31. Why are the cores of large transformers built up of circular cross-section?

The excessive leakage fluxes produced during short circuit and over loads develop mechanical stresses in the coils. These forces are radial in circular coils and there is no tendency for the coil to change its shape. But in rectangular coils, these forces are perpendicular and tend to deform the coil.

Give the expression for window width that gives the maximum output.

The width of the window for maximum output is

$$W_w = D - d = 0.7 d.$$

Where D = distance between adjacent limbs

d = width occupied by iron

33. Give the expression for KVA rating of a single and three phase transformer.

Rating of a single phase & three phase transformer in KVA is given as

$$= 2.22 f B_m \delta K_w A_w A_i * 10^{-3}$$

Where f = frequency, Hz

B_m = maximum flux density, Wb/m²

δ = current density, A/mm²

K_w = Window space factor

A_w = Window area, m²

A_i = Net core area, m²

Mention different types of low voltage windings.

Cylindrical windings

Helical winding

What is the range of efficiency of a transformer? The efficiency will be in the range of 94% to 99%.

In transformers, why the low voltage winding is placed near the core?

The winding & core are both made of metals and so insulation has to be placed in between them. The thickness of insulation depends on the voltage rating of the winding. In order to reduce the insulation requirement the low voltage winding is placed near the core.

37. What are the disadvantages of stepped cores?

With large number of steps a large number of different sizes of laminations have to be used. This results in higher labor charges for shearing and assembling different types of laminations.

What is the objective behind using sheet steel stampings in the construction of electrical machines?

The stampings are used to reduce the eddy current losses. The stampings are insulated by a thin coating of varnish, hence when the stampings are stacked to form a core, the resistance for the eddy current is very high.

What type of steel is commonly used for the core of transformer?

The hot rolled and cold rolled silicon steel with 3 to 5% silicon are used for the laminations of the core of transformers. The hot rolled silicon steel allows a maximum flux density of 1.45 Wb/m² and the cold rolled silicon steel permits a maximum flux density of 1.8 Wb/m².

What is tertiary winding?

Some three phase transformers may have a third winding called tertiary winding apart from primary and secondary. It is also called auxiliary winding or stabilizing winding.

The tertiary winding is provided in a transformer for any one of the following reasons:

To supply small additional load at a different voltage

To give supply to phase compensating devices such as capacitors which work at different voltage

To limit short circuit current

To indicate voltage in high voltage testing transformer

How the tertiary winding is connected? Why?

The tertiary winding is normally connected in delta. When the tertiary is connected in delta, the unbalance in the phase voltage during unsymmetrical faults in primary or secondary is compensated by the circulating currents flowing in the closed delta.

What are the salient features of distribution transformer?

- The distribution transformers will have low iron loss and higher value of copper loss.
- The capacity of transformers will be up to 500 KVA
- The transformers will have plain walled tanks are provided with cooling tubes or radiators
- The leakage reactance and regulation will be low.

What types of forces acts on the coils of a transformer in the event of a short circuit on a transformer?

During short circuit conditions the radial forces will be acting on the coil, which is due to short circuit currents.

What is the range of current densities used in the design of transformer winding?

The choice of current density depends on the allowable temperature rise, copper loss and method of cooling. The range of current density for various types of transformers is given below:

- $\delta = 1.1$ to 2.2 A/mm^2 - For distribution transformers
- $\delta = 1.1$ to 2.2 A/mm^2 - For small power transformers with self oil cooling
- $\delta = 2.2$ to 3.2 A/mm^2 - For large power transformers with self oil cooling

➤ $\delta = 5.4$ to 6.2 A/mm^2 - For large power transformers with forced circulation of oil

44. How the heat dissipates in a transformer?

The heat dissipation in a transformer occurs by conduction, convection and Radiation.

45. How the leakage reactance of a transformer is reduced?

In transformers the leakage reactance is reduced by interleaving the high voltage, and low voltage winding.

46. How the magnetic curves are used for calculating the no-load current of a transformer?

The B –H curve can be used to find the mmf per metre for the flux densities in yoke and core. The loss curve can be used to estimate the iron loss per Kg for the flux densities in yoke and core.

47. What is conservator?

A conservator is a small cylindrical drum fitted just above the transformer main tank. It is used to allow the expansion and contraction of oil without contact with surrounding atmosphere.

When conservator is fitted in a transformer, the tank is fully filled with oil and the conservator is half filled with oil.

48. Why silica gel is used in breather?

The silica gel is used to absorb the moisture when the air is drawn from atmosphere into the transformer.

What are the merits and demerits of using water for forced cooling of transformers?

The advantage in forced water cooling is that large amount of heat can be removed quickly from the transformer.

The disadvantage in forced water cooling is that the water may leak into oil and the oil may be contaminated.

In mines applications transformers with oil cooling should not be used, why?

The oil used for transformer cooling is inflammable. Hence leakage of cooling oil may create fore accidents in mines. Therefore oil cooled transformers are not used in mines.

UNIT IV INDUCTION MOTORS

Output equation of Induction motor – Main dimensions – Length of air gap- Rules for selecting rotor slots of squirrel cage machines – Design of rotor bars & slots – Design of end rings – Design of wound rotor – Magnetic leakage calculations – Leakage reactance of polyphase machines- Magnetizing current - Short circuit current – Circle diagram - Operating characteristics.

4.1.Introduction:

Induction motors are the ac motors which are employed as the prime movers in most of the industries. Such motors are widely used in industrial applications from small workshops to large industries. These motors are employed in applications such as centrifugal pumps, conveyers, compressors crushers, and drilling machines etc.

Constructional Details:

Similar to DC machines an induction motor consists of a stationary member called stator and a rotating member called rotor. However the induction motor differs from a dc machine in the following aspects.

Laminated stator

Absence of commutator

Uniform and small air gap

Practically almost constant speed

The AC induction motor comprises two electromagnetic parts:

Stationary part called the stator

Rotating part called the rotor

The stator and the rotor are each made up of

- An electric circuit, usually made of insulated copper or aluminum winding, to carry current

- A magnetic circuit, usually made from laminated silicon steel, to carry magnetic flux

The stator

The stator is the outer stationary part of the motor, which consists of

The outer cylindrical frame of the motor or yoke, which is made either of welded sheet steel, cast iron or cast aluminum alloy.

The magnetic path, which comprises a set of slotted steel laminations called stator core pressed into the cylindrical space inside the outer frame. The magnetic path is laminated to reduce eddy currents, reducing losses and heating.

• A set of insulated electrical windings, which are placed inside the slots of the laminated stator. The cross-sectional area of these windings must be large enough for the power rating of the motor. For a 3-phase motor, 3 sets of windings are required, one for each phase connected in either star or delta. Fig 1 shows the cross sectional view of an induction motor. Details of construction of stator are shown in Figs

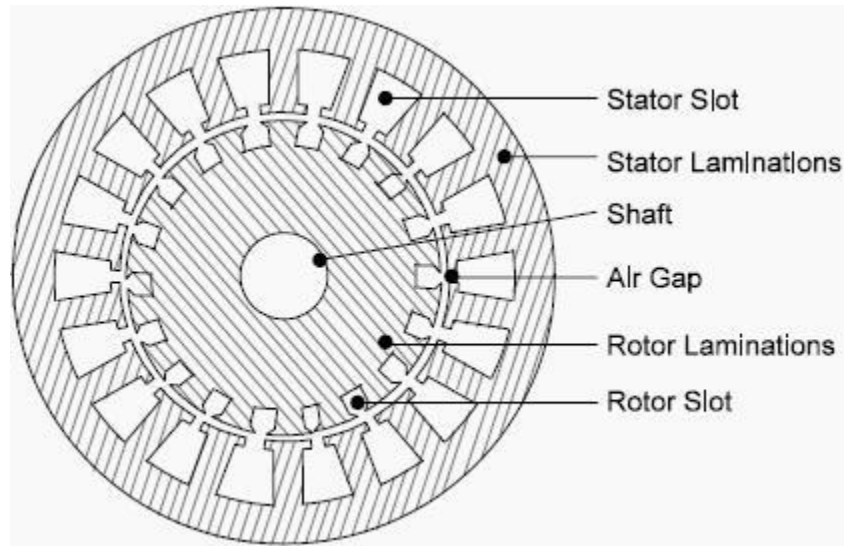

Fig 1: Stator and rotor laminations

The rotor

Rotor is the rotating part of the induction motor. The rotor also consists of a set of slotted silicon steel laminations pressed together to form of a cylindrical magnetic circuit and the electrical circuit. The electrical circuit of the rotor is of the following nature

Squirrel cage rotor consists of a set of copper or aluminum bars installed into the slots, which are connected to an end-ring at each end of the rotor. The construction of this type of rotor along with windings resembles a ‘squirrel cage’. Aluminum rotor bars are usually die-cast into the rotor slots, which results in a very rugged construction. Even though the aluminum rotor bars are in direct contact with the steel laminations, practically all the rotor current flows through the aluminum bars and not in the lamination

Wound rotor consists of three sets of insulated windings with connections brought out to three slip rings mounted on one end of the shaft. The external connections to the rotor are made through brushes onto the slip rings as shown in fig 7. Due to the presence of slip rings such type of motors are called slip ring motors. Sectional view of the full induction motor is shown in Fig. 8

Some more parts, which are required to complete the constructional details of an induction motor, are:

Two end-flanges to support the two bearings, one at the driving-end and the other at the non driving-end, where the driving end will have the shaft extension.

Two sets of bearings to support the rotating shaft,

Steel shaft for transmitting the mechanical power to the load

Cooling fan located at the non driving end to provide forced cooling for the stator and rotor

Terminal box on top of the yoke or on side to receive the external electrical connections

Figure 2 to show the constructional details of the different parts of induction motor.



Fig. 2 Stator laminations

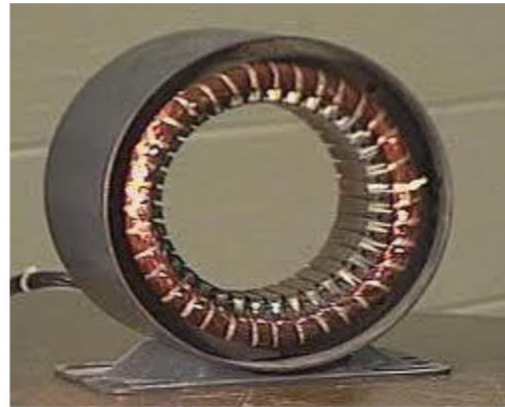

Fig. 3 stator core with smooth yoke



Fig.4 Stator with ribbed yoke



Fig 5. Squirrel cage rotor



Fig. 6. Slip ring rotor

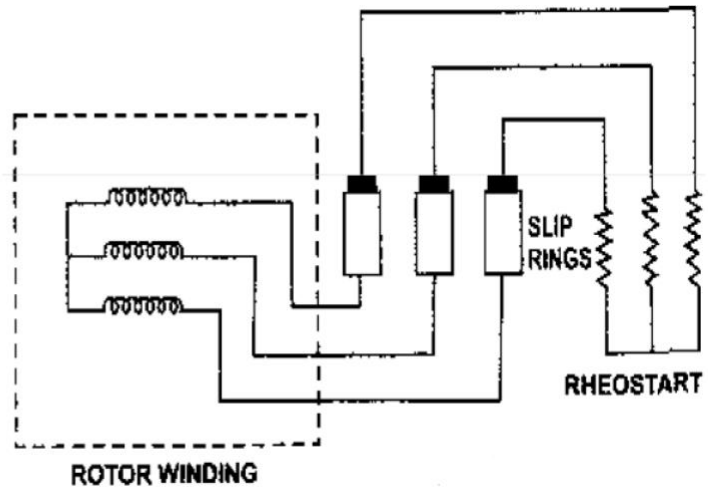

Fig 7. Connection to slip rings



Fig. 8 Cut sectional view of the induction motor.

Introduction to Design

The main purpose of designing an induction motor is to obtain the complete physical dimensions of all the parts of the machine as mentioned below to satisfy the customer specifications. The following design details are required.

- The main dimensions of the stator.
- Details of stator windings.
- Design details of rotor and its windings
- Performance characteristics.

In order to get the above design details the designer needs the customer specifications Rated output power, rated voltage, number of phases, speed, frequency, connection of stator winding, type of rotor winding, working conditions, shaft extension details etc.

In addition to the above the designer must have the details regarding design equations based on which the design procedure is initiated, information regarding the various choice of

parameters, information regarding the availability of different materials and the limiting values of various performance parameters such as iron and copper losses, no load current, power factor, temperature rise and efficiency

4.2. Output equation of Induction motor

output equation is the mathematical expression which gives the relation between the various physical and electrical parameters of the electrical machine.

In an induction motor the out put equation can be obtained as follows Consider an 'm' phase machine, with usual notations

Out put Q in kW = Input x efficiency

Input to motor = $mV_{ph} I_{ph} \cos \Phi \times 10^{-3}$ kW For a 3 Φ machine $m =$

3 Input to motor = $3V_{ph} I_{ph} \cos \Phi \times 10^{-3}$ kW Assuming

$V_{ph} = E_{ph}$, $V_{ph} = E_{ph} = 4.44 f \Phi T_{ph} K_w$

$= 2.22 f \Phi Z_{ph} K_w$

$f = P_N S / 120 = P_n s / 2,$

Output = $3 \times 2.22 \times P_n s / 2 \times \Phi Z_{ph} K_w I_{ph} \eta \cos \Phi \times 10^{-3}$

kW Output = $1.11 \times P \Phi \times 3 I_{ph} Z_{ph} \times n_s K_w \eta \cos \Phi \times 10^{-3}$

$^3 \text{kW } P \Phi = B_{av} \pi D L,$ and $3 I_{ph} Z_{ph} / \pi D = q$

Output to motor = $1.11 \times B_{av} \pi D L \times \pi D q \times n_s K_w \eta \cos \Phi \times 10^{-3}$ kW

$Q = (1.11 \pi^2 B_{av} q K_w \eta \cos \Phi \times 10^{-3}) D^2 L n_s$ kW

$Q = (11 B_{av} q K_w \eta \cos \Phi \times 10^{-3}) D^2 L n_s$ kW

Therefore Output $Q = C_o D^2 L n_s$ kW

where $C_o = (11 B_{av} q K_w \eta \cos \Phi \times 10^{-3})$

V_{ph} = phase voltage ; I_{ph} = phase current

Z_{ph} = no of conductors/phase

T_{ph} = no of turns/phase

N_s = Synchronous speed in rpm

n_s = synchronous speed in rps

p = no of poles,

q = Specific electric loading

Φ = air gap flux/pole;

B_{av} = Average flux density

k_w = winding factor

= efficiency $\cos\Phi$ =

power factor

D = Diameter of the stator,

L = Gross core length

Co = Output coefficient

4.3.Main dimensions

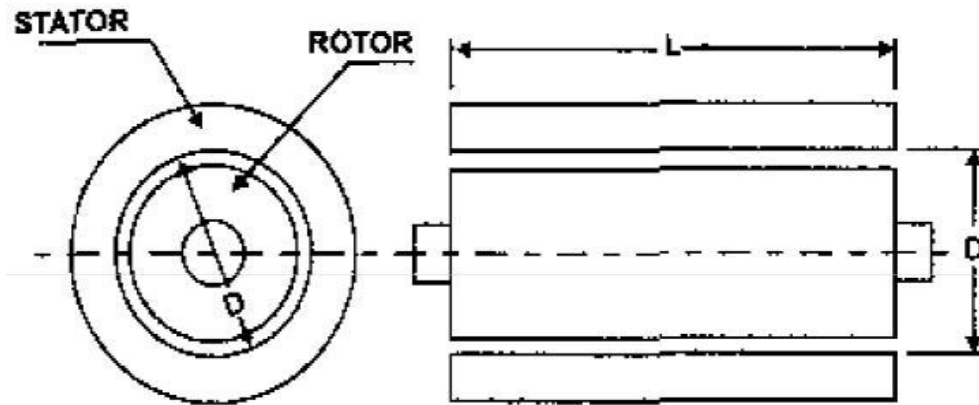

Fig.9 shows the details of main dimensions of the of an induction motor.

4.4.Length of air gap

Magnetizing current and power factor being very important parameters in deciding the performance of induction motors, the induction motors are designed for optimum value of air gap or minimum air gap possible. Hence in designing the length of the air gap following empirical formula is employed.

$$\text{Air gap length } l_g = 0.2 + 2 \text{ mm}$$

4.5.Rules for selecting rotor slots of squirrel cage machines

- Number of stator slots should not be equal to rotor slots satisfactory results are obtained when S_r is 15 to 30% larger or smaller than S_s .
- The difference ($S_s - S_r$) should not be equal to + or - p, + or - 2p or + or - 5 p to avoid synchronous cusps.
- The difference ($S_s - S_r$) should not be equal to + or - 1, + or - 2, + or - (p+1) or + or - (p+2) to avoid noise and vibrations.

Ex. 1. Obtain the following design information for the stator of a 30 kW, 440 V, 3 , 6 pole, 50 Hz delta connected, squirrel cage induction motor, (i) Main dimension of the stator, (ii) No. of turns/phase (iii) No. of stator slots, (iv) No. of conductors per slot. Assume suitable values for the missing design data.

EE8002 DESIGN OF ELECTRICAL APPARATUS **Ex. 2** A 15 kW 440m volts 4 pole, 50 Hz, 3 phase induction motor is built with a stator bore of 0.25 m and a core length of 0.16 m. The specific electric loading is 23000 ac/m. Using data of this machine determine the core dimensions, number of slots and number of stator conductors for a 11kW, 460 volts, 6 pole, 50 Hz motor. Assume full load efficiency of 84 % and power factor of 0.82. The winding factor is 0.955.

Ex. 3 Determine main dimensions, turns/phase, number of slots, conductor size and area of slot of 250 HP, 3 phase, 50 Hz, 400 volts, 1410 rpm, slip ring induction motor. Assume $B_{av} = 0.5 \text{ wb/m}^2$, $q = 30000 \text{ ac/m}$, efficiency = 90 % and power factor = 0.9, winding factor = 0.955, current density = 3.5 a/mm^2 , slot space factor = 0.4 and the ratio of core length to pole pitch is 1.2. the machine is delta connected. (July 2007)

Ex. 4. During the preliminary design of a 270 kW, 3600 volts, 3 phase, 8 pole 50 Hz slip ring induction motor the following design data have been obtained. Gross length of the stator core = 0.38 m, Internal diameter of the stator = 0.67 m, outer diameter of the stator = 0.86 m, No. of stator slots = 96, No. of conductors /slot = 12, Based on the above information determine the following design data for the motor. (i) Flux per pole (ii) Gap density (iii) Conductor size (iv) size of the slot (v) copper losses (vi) flux density in stator teeth (vii) flux density in stator core.

4.6.Design of rotor bars & slots

There are two types of rotor construction. One is the squirrel cage rotor and the other is the slip ring rotor. Most of the induction motor are squirrel cage type. These are having the advantage of rugged and simple in construction and comparatively cheaper. However they have the disadvantage of lower starting torque. In this type, the rotor consists of bars of copper or aluminum accommodated in rotor slots. In case slip ring induction motors the rotor complex in construction and costlier with the advantage that they have the better starting torque. This type of rotor consists of star connected distributed three phase windings. Between stator and rotor is the air gap which is a very critical part. The performance parameters of the motor like magnetizing current, power factor, over load capacity, cooling and noise are affected by length of the air gap. Hence length of the air gap is selected considering the advantages and disadvantages of larger air gap length.

Advantages:

- Increased overload capacity
- Increased cooling
- Reduced unbalanced magnetic pull
- Reduced in tooth pulsation

(v) Reduced noise

Disadvantages

Increased Magnetising current

Reduced power factor



Slip ring rotor

Squirrel cage rotor

Number of slots: Proper numbers of rotor slots are to be selected in relation to number of stator slots otherwise undesirable effects will be found at the starting of the motor. Cogging and Crawling are the two phenomena which are observed due to wrong combination of number of rotor and stator slots. In addition, induction motor may develop unpredictable hooks and cusps in torque speed characteristics or the motor may run with lot of noise. Let us discuss Cogging and Crawling phenomena in induction motors.

Crawling: The rotating magnetic field produced in the air gap of the will be usually nonsinusoidal and generally contains odd harmonics of the order 3rd, 5th and 7th. The third harmonic flux will produce the three times the magnetic poles compared to that of the fundamental. Similarly the 5th and 7th harmonics will produce the poles five and seven times the fundamental respectively. The presence of harmonics in the flux wave affects the torque speed characteristics. The Fig. below shows the effect of 7th harmonics on the torque speed characteristics of three phase induction motor. The motor with presence of 7th harmonics is to have a tendency to run the motor at one seventh of its normal speed. The 7th harmonics will produce

EE8002 DESIGN OF ELECTRICAL APPARATUS a dip in torque speed characteristics at one seventh of its normal speed as shown in torque speed characteristics.

Cogging: In some cases where in the number of rotor slots are not proper in relation to number of stator slots the machine refuses to run and remains stationary. Under such conditions there will be a locking tendency between the rotor and stator. Such a phenomenon is called cogging. Hence in order to avoid such bad effects a proper number of rotor slots are to be selected in relation to number of stator slots. In addition rotor slots will be skewed by one slot pitch to minimize the tendency of cogging, torque defects like synchronous hooks and cusps and noisy operation while running. Effect of skewing will slightly increase the rotor resistance and increases the starting torque. However this will increase the leakage reactance and hence reduces the starting current and power factor.

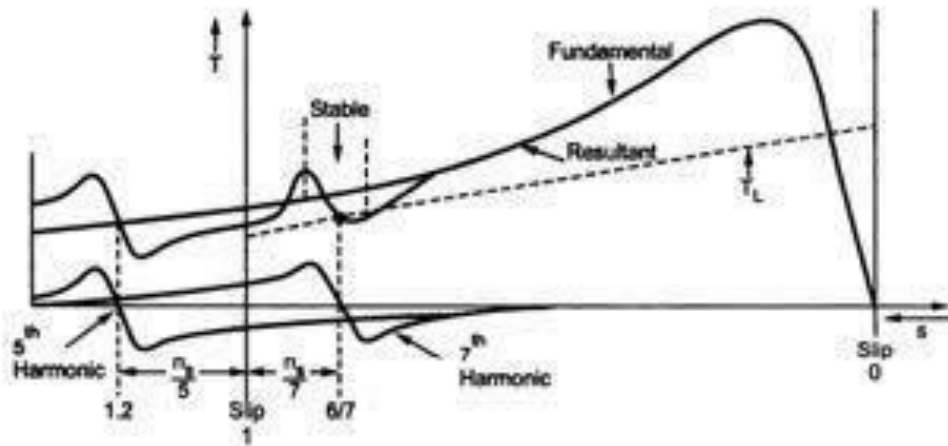

4.7. Selection of number of rotor slots: The number of rotor slots may be selected using the following guide lines.

- (i) To avoid cogging and crawling: (a) $S_s - S_r \neq \pm 3P$
- (ii) To avoid synchronous hooks and cusps in torque speed characteristics $\pm P, \pm 2P, \pm 5P$.
- (iii) To noisy operation $S_s - S_r \neq \pm 1, \pm 2, (\pm P \pm 1), (\pm P \pm 2)$

Rotor Bar Current: Bar current in the rotor of a squirrel cage induction motor may be determined by comparing the mmf developed in rotor and stator. Hence the current per rotor bar is given by $I_b = (K_{ws} \times S_s \times Z'_s) \times I_r / (K_{wr} \times S_r \times Z'_r)$;

where K_{ws} – winding factor for the stator,

S_s – number of stator slots,

Z'_s – number of conductors / stator slots,

K_{wr} – winding factor for the rotor,

S_r – number of rotor slots,

I_r – equivalent rotor current in terms of stator current and is given by

$I_r = 0.85 I_s$ where I_s is stator current per phase.

Cross sectional area of Rotor bar:

Sectional area of the rotor conductor can be calculated by rotor bar current and assumed value of current density for rotor bars. As cooling conditions are better for the rotor than the stator higher current density can be assumed. Higher current density will lead to reduced sectional area and hence increased resistance, rotor cu losses and reduced efficiency. With increased rotor resistance starting torque will increase. As a guide line the rotor bar current density can be assumed between 4 to 7 Amp/mm² or may be selected from design data Hand Book.

Hence sectional area of the rotor bars can be calculated as $A_b = I_b / j_b \text{ mm}^2$. Once the cross sectional area is known the size of the conductor may be selected from standard table given in data hand book.

Shape and Size of the Rotor slots: Generally semiclosed slots or closed slots with very small or narrow openings are employed for the rotor slots. In case of fully closed slots the rotor bars are force fit into the slots from the sides of the rotor. The rotors with closed slots are giving better performance to the motor in the following way.

As the rotor is closed the rotor surface is smooth at the air gap and hence the motor draws lower magnetizing current.

reduced noise as the air gap characteristics are better

increased leakage reactance and

reduced starting current.

Over load capacity is reduced

Undesirable and complex air gap characteristics. From the above it can be concluded that semiclosed slots are more suitable and hence are employed in rotors

Copper loss in rotor bars:

Knowing the length of the rotor bars and resistance of the rotor bars cu losses in the rotor bars can be calculated. Length of rotor bar $l_b = L + \text{allowance for skewing}$

Rotor bar resistance = $0.021 \times l_b / A_b$

Copper loss in rotor bars = $I_b \times r_b \times \text{number of rotor bars.}$

End Ring Current:

EE8002 DESIGN OF ELECTRICAL APPARATUS All the rotor bars are short circuited by connecting them to the end rings at both the end rings. The

rotating magnetic field produced will induce an emf in the rotor bars which will be sinusoidal over one pole pitch. As the rotor is a short circuited body, there will be current flow because of this EMF induced. The distribution of current and end rings are as shown in Fig. below. Referring to the figure considering the bars under one pole pitch, half of the number of bars and the end ring carry the current in one direction and the other half in the opposite direction. Thus the maximum end ring current may be taken as the sum of the average current in half of the number of bars under one pole.

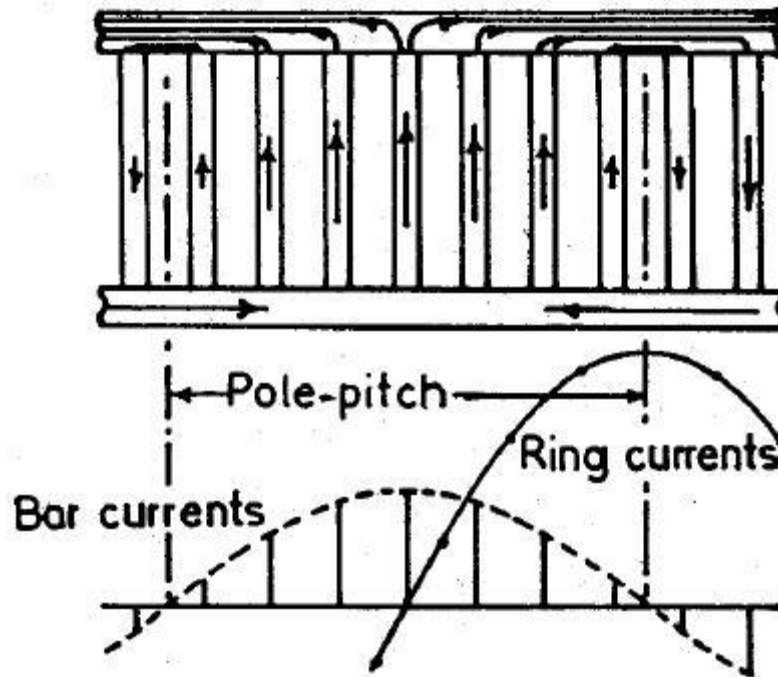

$$\begin{aligned} \text{Maximum end ring current } I_e(\max) &= \frac{1}{2} (\text{Number rotor bars / pole}) I_b(\text{av}) \\ &= \frac{1}{2} \times \frac{S_r}{P} \times I_b / 1.11 \end{aligned}$$

$$\begin{aligned} \text{Hence rms value of } I_e &= \frac{1}{2} \times \frac{S_r}{P} \times I_b / 1.11 \\ &= \frac{1}{\sqrt{2}} \times \frac{S_r}{P} \times I_b / 1.11 \end{aligned}$$

Area of end ring:

Knowing the end ring current and assuming suitable value for the current density in the end rings cross section for the end ring can be calculated as

Area of each end ring $A_e = I_e / j_e \text{ mm}^2$, current density in the end ring may be assume as 4.5 to 7.5 amp/mm².

Copper loss in End Rings:

Mean diameter of the end ring (D_{me}) is assumed as 4 to 6 cms less than that of the rotor. Mean length of the current path in end ring can be calculated as $l_{me} = D_{me}$. The resistance of the end ring can be calculated as $r_e = 0.021 \times l_{me} / A_e$

$$\text{Total copper loss in end rings} = 2 \times I_e^2 \times r_e$$

Equivalent Rotor Resistance:

Knowing the total copper losses in the rotor circuit and the

equivalent rotor current equivalent rotor resistance can be calculated as follows.

Equivalent rotor resistance r'

$$r = \text{Total rotor copper loss} / 3 \times (I_r')^2$$

4.8.Design of wound Rotor:

These are the types of induction motors where in rotor also carries distributed star connected 3 phase winding. At one end of the rotor there are three slip rings mounted on the shaft. Three ends of the winding are connected to the slip rings. External resistances can be connected to these slip rings at starting, which will be inserted in series with the windings which will help in increasing the torque at starting. Such type of induction motors are employed where high starting torque is required.

4.9.Number of rotor slots:

As mentioned earlier the number of rotor slots should never be equal to number of stator slots. Generally for wound rotor motors a suitable value is assumed for number of rotor slots per pole per phase, and then total number of rotor slots are calculated. So selected number of slots should be such that tooth width must satisfy the flux density limitation. Semiclosed slots are used for rotor slots.

Number of rotor Turns: Number of rotor turns are decided based on the safety consideration of the personal working with the induction motors. The voltage between the slip rings on open circuit must be limited to safety values. In general the voltage between the slip rings for low and medium voltage machines must be limited to 400 volts. For motors with higher voltage ratings and large size motors this voltage must be limited to 1000 volts. Based on the assumed voltage between the slip rings comparing the induced voltage ratio in stator and rotor the number of turns on rotor winding can be calculated.

$$\text{Voltage ratio } E_r / E_s = (K_{wr} \times T_r) / (K_{ws} \times T_s)$$

$$\text{Hence rotor turns per phase } T_r = (E_r / E_s) (K_{ws} / K_{wr})$$

$T_s E_r = \text{open circuit rotor voltage/phase}$
 $E_s = \text{stator voltage /phase}$

$K_{ws} = \text{winding factor for stator}$

$K_{wr} = \text{winding factor for rotor}$

T_s = Number of stator turns/phase

Rotor Current

Rotor current can be calculated by comparing the amp-cond on stator and rotor $I_r = (K_{ws} \times S_s \times Z'_s) \times I'_r / (K_{wr} \times S_r \times Z'_r)$; K_{ws} – winding factor for the stator,

S_s – number of stator slots,

Z'_s – number of conductors / stator slots,

K_{wr} – winding factor for the rotor,

S_r – number of rotor slots,

Z'_r – number of conductors / rotor slots and

I'_r – equivalent rotor current in terms of stator current

$I'_r = 0.85 I_s$ where I_s is stator current per phase.

Area of Rotor Conductor: Area of rotor conductor can be calculated based on the assumed value for the current density in rotor conductor and calculated rotor current. Current density rotor conductor can be assumed between 4 to 6 Amp/mm²

$$A_r = I_r / j_r \text{ mm}^2$$

$A_r < 5\text{mm}^2$ use circular conductor, else rectangular conductor, for rectangular conductor width to thickness ratio = 2.5 to 4. Then the standard conductor size can be selected similar to that of stator conductor.

Size of Rotor slot:

Mostly Semi closed rectangular slots employed for the rotors. Based on conductor size, number conductors per slot and arrangement of conductors similar to that of stator, dimension of rotor slots can be estimated. Size of the slot must be such that the ratio of depth to width of slot must be between 3 and 4.

Total copper loss:

Length of the mean Turn can be calculated from the empirical formula $l_{mt} = 2L + 2.3 p + 0.08m$

Resistance of rotor winding is given by $R_r = (0.021 \times l_{mt} \times T_r) / A_r$

$$\text{Total copper loss} = 3 I_r^2 R_r \text{ Watts}$$

Flux density in rotor tooth: It is required that the dimension of the slot is alright from the flux density consideration. Flux density has to be calculated at 1/3rd height from the root of the teeth. This flux density has to be limited to 1.8 Tesla. If not the width of the tooth has to be increased and width of the slot has to be reduced such that the above flux density limitation is satisfied. The flux density in rotor can be calculated by as shown below.

Diameter at 1/3rd height $D_r' = D - \frac{2}{3} \times h_{tr} \times 2$

Slot pitch at 1/3rd height $= r = \frac{D_r'}{S_r}$

Tooth width at this section $= b_{tr} = r - b_{sr}$

Area of one rotor tooth $= a_{tr} = b_{tr} \times l_i$

Iron length of the rotor $l_i = (L - w_d \times n_d)k_i$, k_i = iron space factor

Area of all the rotor tooth / pole $A_{tr} = b_{tr} \times l_i \times S_r / P$

Mean flux density in rotor teeth $B_{tr} = \frac{\Phi}{A_{tr}}$

Maximum flux density in the rotor teeth < 1.5 times B_{tr}

Depth of stator core below the slots:

Below rotor slots there is certain solid portion which is called depth of the core below slots. This depth is calculated based on the flux density and flux in the rotor core. Flux density in the rotor core can be assumed to be between 1.2 to 1.4 Tesla. Then depth of the core can be found as follows.

Flux in the rotor core section $\Phi_c = \frac{1}{2}$

Area of stator core $A_{cr} = \frac{\Phi_c}{B_{cr}}$

Area of stator core $A_{cr} = L_i \times d_{cr}$

Hence, depth of the core $d_{cr} = A_{cr} / L_i$

Inner diameter of the rotor can be calculated as follows

Inner diameter of rotor $= D - 2l_g - 2h_{tr} - 2d_{cr}$

PROBLEMS:

EX.1. During the stator design of a 3 phase, 30 kW, 400volts, 6 pole, 50Hz,squirrel cage induction motor following data has been obtained. Gross length of the stator = 0.17 m, Internal diameter of stator = 0.33 m, Number of stator slots = 45, Number of conductors per slot = 12. Based on the above design data design a suitable rotor.

EX.2. A 3 phase 3000 volts 260 kW, 50 Hz, 10 pole squirrel cage induction motor gave the following results during preliminary design. Internal diameter of the stator = 75 cm, Gross length of the stator = 35 cm, Number of stator slots = 120, Number of conductor per slot =10. Based on the above data calculate the following for the squirrel cage rotor. (i) Total losses in rotor bars, (ii) Losses in end rings, (iii) Equivalent resistance of the rotor.

EX.3. A 3 phase 200 kW, 3.3 kV, 50 Hz, 4 pole induction motor has the following dimensions. Internal diameter of the stator = 56.2 cm, outside diameter of the stator = 83cm, length of the stator = 30.5 cm, Number of stator slots = 60, width of stator slot = 1.47 cm, depth of stator slot = 4.3 cm, radial gap = 0.16 cm, number of rotor slots = 72, depth of rotor slot 3.55 cm, width of rotor slots = 0.95 cm.

EE8002 DESIGN OF ELECTRICAL APPARATUS Assuming air gap flux density to be 0.5 Tesla, calculate the flux density in (i) Stator teeth (ii) Rotor teeth (iii) stator core.

EX.4. Following design data have been obtained during the preliminary design of a 3 phase, 850 kW, 6.6 kV, 50 Hz, 12 pole slip ring induction motor. Gross length of stator core = 45 cm, internal diameter of the stator core = 122 cm, number of stator slots = 144, Number of conductors per slot = 10. For the above stator data design a wound rotor for the motor.

4.10. Magnetic leakage calculations

Leakage factor or Leakage coefficient LC.

All the flux produced by the pole will not pass through the desired path i.e., air gap. Some of the flux produced by the pole will be leaking away from the air gap. The flux that passes through the air gap and cut by the armature conductors is the useful flux and that flux that leaks away from the desired path is the leakage flux

$$\text{Thus } \phi_p = \phi + \phi_l$$

As leakage flux is generally around (15 to 25) % of ϕ ,

$$\begin{aligned}\phi_p &= \phi + (0.15 \text{ to } 0.25) \phi \\ &= LC \times \phi\end{aligned}$$

where LC is the Leakage factor or Leakage coefficient and lies between (1.15 to 1.25). Magnitude of flux in different parts of the magnetic circuit

4.11. Leakage reactance of polyphase machines

Leakage reactance = $2\pi f \times$ inductance = $2\pi f \times$ Flux linkage / current

Note:

Useful flux: It is the flux that links with both primary and secondary windings and is responsible in transferring the energy Electro-magnetically from primary to secondary side. The path of the useful flux is in the magnetic core.

Leakage flux: It is the flux that links only with the primary or secondary winding and is responsible in imparting inductance to the windings. The path of the leakage flux depends on the geometrical configuration of the coils and the neighboring iron masses.

4.12. Magnetizing current

Effect of magnetizing current and its effect on the power factor can be understood from the phasor diagram of the induction motor shown in Fig.

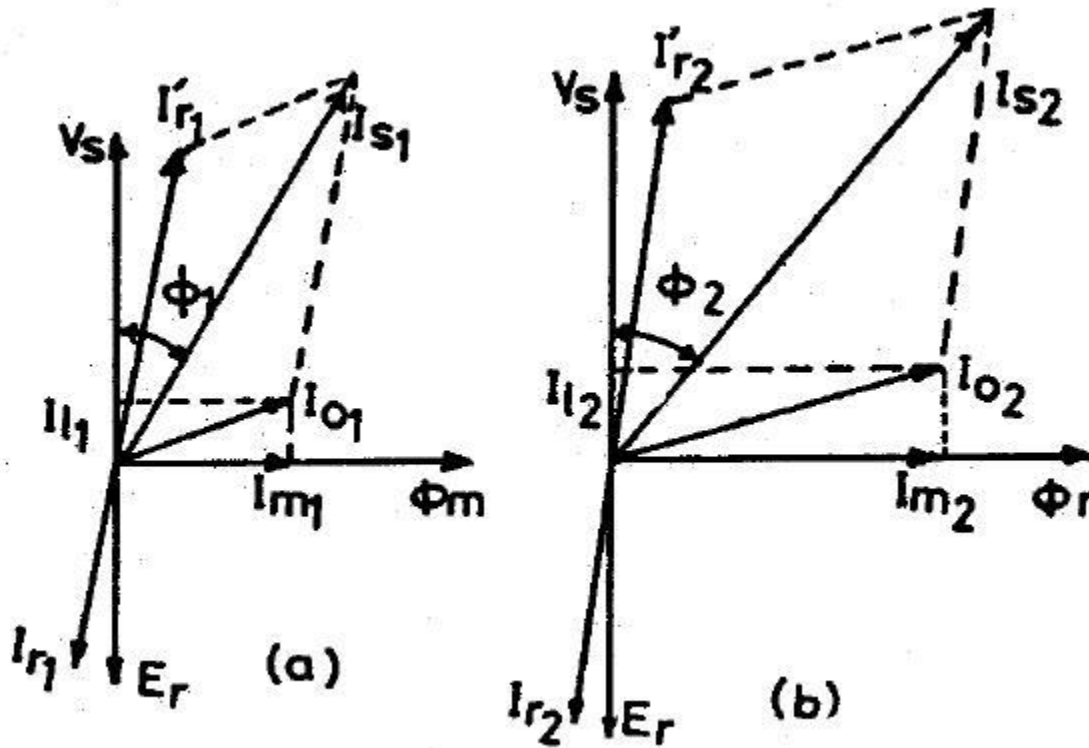

Phasor diagram of induction motor

Magnetizing current and power factor being very important parameters in deciding the performance of induction motors, the induction motors are designed for optimum value of air gap or minimum air gap possible. Hence in designing the length of the air gap following empirical formula is employed.

Air gap length $l_g = 0.2 + 2 \sqrt{\quad}$ mm

4.13. Short circuit current

Short circuit current

$$\downarrow \text{SCR} = \frac{1}{X_s \uparrow}, X_s \uparrow \Rightarrow Z_s \uparrow, Z_s \uparrow, I_{sc} \downarrow = \frac{E_s}{Z_s \downarrow}$$

4.14. Circle diagram

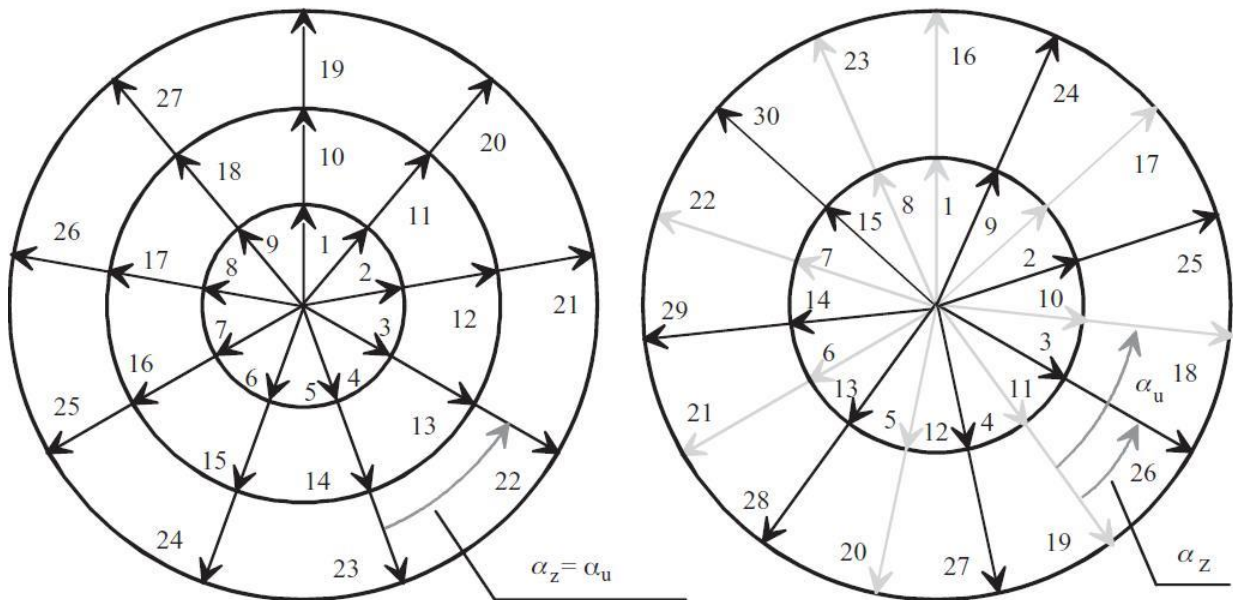

Both of the layers of the voltage phasor diagram have to be circled twice in order to number all the phasors.

4.15. Operating characteristics.

Now, the equivalent circuit of an asynchronous motor per phase, the quantities of which are calculated in the machine design, is worth recollecting. Figure 7.12 illustrates a single-phase equivalent circuit of an ordinary induction motor per phase, a simplified equivalent circuit and a phasor diagram.

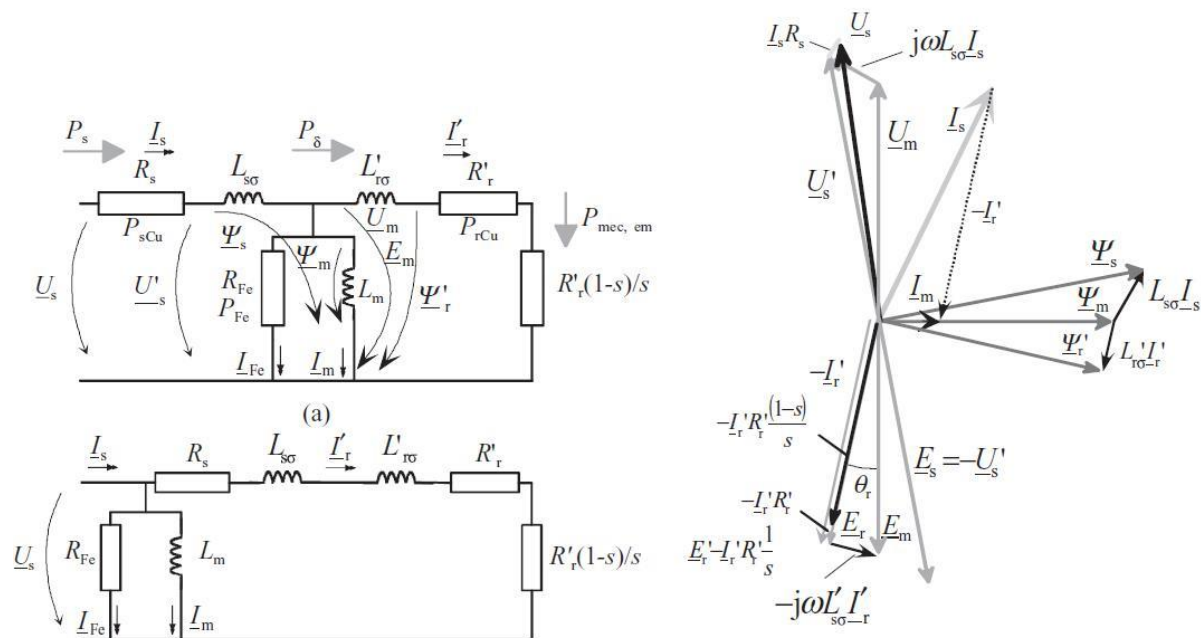

QUESTION BANK**Unit-IV INDUCTION MOTORS****1. Define slot space factor.**

The slot space factor is the ratio of conductor area per slot and slot area. It gives an indication of the space occupied by the conductors and the space available for insulation. The slot space factor for induction motor varies from 0.25 to 0.4.

2. Define distribution factor or breadth factor.

It is defined as the ratio of resultant emf when the winding is uniformly distributed to the resultant emf when the winding is bunched in the slot.

3. Define winding factor.

It is defined as the product of the pitch factor and the distribution factor.

$$K_w = K_p * K_d$$

Why the low voltage winding is placed nearer to the core and the high voltage winding in case of a core type transformer.

Insulation required will be less
Less possibility for fault occurrence
Easy to provide tapings

Why is it possible to design alternators to generate much higher voltage than dc generator? In alternator the winding is provided in stator and hence maximum voltage can be provided.

In dc generator the winding is provided in rotor and hence it is not possible to generate maximum voltage

Why rotating machines with aluminum armature coils have increased leakage reactance?

Aluminum coils in armature require more space for accommodation of conductors. Large size slots are designed. Hence with large size slots the value of leakage reactance increases.

7. Why the harmonic leakage flux in squirrel cage induction motor is zero?

Since the rotor current balances the stator current at every point there is no harmonic leakage flux.

Stepped core section is preferred to a square section for transformer, give reason?

Diameter of circumscribing circle can be reduced giving use of less copper

Due to increase in core area flux density can be reduced which results less iron loss.

Why choice of high specific loading in the design of synchronous generators leads to poor voltage regulation?

High value of specific electric loading will mean more number of turns per phase. This will cause high value of leakage reactance and poor voltage regulation.

Define real flux density.

It is defined as the ratio of actual flux through the tooth to the tooth area.

List the advantages and disadvantages of using closed type of rotor slot in squirrel cage induction motor.**Advantages:**

Low reluctances
Less magnetizing current
Quieter operation
Large leakage reactance and so starting current is limited

Disadvantages:

Reduced over load capacity

Write the expression for rotor current.

$$0.85 I_s T_s$$

The rotor current $I_r = \frac{0.85 I_s T_s}{T_r}$

Where T_s = number of turns per phase for stator
 T_r = number of turns per phase for rotor
 I_s = Stator current

What are the ranges of efficiency and power factor in induction motor?

Squirrel cage motor:

Efficiency = **72 to 91%**
 Power factor = **0.66 to 0.9**

Slip ring motor:

Efficiency = **84 to 91%**
 Power factor = **0.7 to 0.92.**

The approximate efficiency of a three phase, 50 Hz, 4 pole induction motor running at 1350 rpm is -----

90% ii) 40% iii) 65% iv) None of the above.

Ans : i) 90%

What is the approximate efficiency of a 60 Hz, 6 pole, 3 phase induction motor running at 1050 rpm?

72% ii) 81.2% iii) 76.8% iv) 87.5%.

Ans : iv) 87.5%

What is integral slot winding and fractional slot winding?

In integral slot winding, the total number of slots is chosen such that the slots per pole are an integer, which should be a multiple of number of phases. In fractional slot winding, the total number of slots is chosen such that the slots per pole are not an integer.

Why fractional slot winding is not used for induction motor?

Windings with fractional number of slots per pole per phase create asymmetrical mmf distribution around the air gap and favour the creation of noise in the motor. Therefore, fractional windings are not used in induction motor starter.

Write the expression for length of mean turn of stator winding?

$$\text{Length of mean turn of stator, } L_{mts} = 2L + 2.3 \tau + 0.24$$

Where L = Stator core length
 τ = pole pitch = $\pi D / p$

Name the methods used for reducing harmonic torques.

- Chording
- Integral slot winding
- Skewing and
- Increasing the length of air gap

What is Skewing?

Skewing is twisting either the stator or rotor core. The motor noise, vibrations, cogging and synchronous cusps can be reduced or even entirely eliminated by skewing either the stator or the rotor.

Give the expression for rotor current.

$$6 I_s T_s$$

The rotor bar current is given by $I_b = \frac{6 I_s T_s}{S_r} K_{ws} \cos \phi$

Where I_s = stator current /phase
 T_s = stator turns / phase

S_r = Number of rotor slots

What is full pitch and short pitch or chording?

When the coil span is equal to pole pitch (180 deg electrical), the winding is called full pitched winding. When the coil span is less than pole pitch (180 deg electrical), the winding is called short pitched or chorded.

What are the different types of stator windings in induction motor?

Mush winding
Lap winding and
Wave winding

How the induction motor can be designed for best power factor?

For best power factor, the pole pitch τ is chosen such that $\tau = \text{SQRT} [(0.18 L)]$.

What are the ranges of specific magnetic loading and specific electric loading in induction motor?

Specific magnetic loading = 0.3 to 0.6 Wb / m²

Specific electric loading = 5000 to 45000 amp.cond/m

What are the materials used for slip rings and brushes in induction motor?

The slip rings are made of brass or phosphor bronze. The brushes are made of metal graphite, which is an alloy of copper and carbon.

Write the expression for output equation and output co-efficient of induction motor. The equation for input KVA is considered as output equation in induction motor.

The input KVA, $Q = C_0 D^2 L n_s$ in KVA

Output co-efficient $C_0 = 11 B_{av} ac K_{ws} * 10^{-3}$ in KVA/ m³ – rps.

List the advantages of using open slots.

The advantages are:

The winding coils can be formed and fully insulated before installing and also it is easier to replace the individual coils.
It avoids excessive slot leakage thereby reducing the leakage reactance.

Give the advantages of using semi-enclosed stator slots.

The advantages are less air gap contraction factor giving a small value of magnetizing current, low tooth pulsation loss and mush quieter operation(less noise). Semi enclosed slots are mostly preferred for induction motor.

What is the maximum value of flux density in stator teeth?

The maximum value of flux density in stator tooth should not exceed 1.7 Wb/m².

A high value of flux density leads to a higher iron loss and a greater magnetizing mmf.

What are the problems that occur in induction motor due to certain combinations of stator and rotor slots?

The problems in induction motor due to certain combinations of stator and rotor slots are

The motor may refuse to start
The motor may crawl at some sub-synchronous speed
Severe vibrations are developed and so the noise will be excessive 32. .

List the rules for selecting rotor slots.

Number of stator slots should not be equal to rotor slots satisfactory results are obtained when S_r is 15 to 30% larger or smaller than S_s .

The difference ($S_s - S_r$) should not be equal to + or - p, + or - 2p or + or - 5 p to avoid synchronous cusps.

The difference ($S_s - S_r$) should not be equal to + or - 1, + or - 2, + or - (p+1) or + or - (p+2) to avoid noise and vibrations.

What are the main dimensions of induction motor?

Stator core internal diameter
Stator core length

Why induction motor is called as rotating transformer?

The principle of operation of induction motor is similar to that of a transformer. The stator winding is equivalent to primary of a transformer. The rotor winding is equivalent to short circuited secondary of a transformer. In transformer, the secondary is fixed but in induction motor it is allowed to rotate.

35. How slip ring motor is started?

The slip ring motor is started by using rotor resistance starter. The starter consists of star connected variable resistances and protection circuits. The resistances are connected to slip rings. While starting, full resistance is included in the rotor circuit to get high starting torque. Once the rotor starts rotating, the resistances are gradually reduced in steps. At running condition, the slip rings are shorted and so it is equivalent to squirrel cage rotor.

What are the special features of the cage rotor of induction machine?

The cage rotor can adopt itself for any number of phases and poles
It is suitable for any type of starting method except using rotor resistance starter
It is cheaper and rugged
Rotor overhang leakage reactance is lesser which results in better power factor, greater pull out torque and over load capacity.

Name the materials used to insulate the laminations of the core of induction motor.

The materials used to insulate the laminations of the core of induction motor are kaolin and varnish.

38. Where mush winding is used?

The mush winding is used in small induction motors of ratings less than 5HP.

39. What is the minimum value of slot pitch of a 3 phase induction motor?

The minimum value of slot pitch of a 3 phase induction motor is 15 mm.

Write the formula for air-gap in case of three phase induction motor in terms of length and diameter.

The length of air-gap, $l_g = 0.2 + 2 \text{ SQRT}[(D L)]$ in mm Where D and L are expressed in meters.

What is crawling and cogging?

Crawling is a phenomenon in which the induction motor runs at a speed lesser than sub synchronous speed.

Cogging is a phenomenon in which the induction motor refuses to start.

42. What is harmonic induction torque and harmonic synchronous torque?

Harmonic induction torques are torques produced by harmonic fields due to stator winding and slots.

Harmonic synchronous torques are torques produced by the combined effect of same order of stator and rotor harmonic fields.

What is the condition for obtaining the maximum torque in case of 3-phase induction motor?

The maximum torque occurs in induction motor when rotor reactance is equal to rotor resistance.

What is runaway speed?

The runaway speed is defined as the speed which the prime mover would have, if it is suddenly unloaded, when working at its rated speed.

State three important features of turbo-alternator rotors.

The rotors of turbo-alternators have large axial length and small diameters
Damping torque is provided by the rotor itself and so there is no necessity for additional damper winding
They are suitable for high speed operations and so number of poles is usually 2 or 4.

Distinguish between cylindrical pole and salient pole construction.

In cylindrical pole construction the rotor is made of solid cylinder and slots are cut on the outer periphery of the cylinder to accommodate field conductors.

In salient pole construction, the circular or rectangular poles are mounted on the outer surface of a cylinder. The field coils are fixed on the pole.

The cylindrical pole construction is suitable for high speed operations, whereas the salient pole construction is suitable for slow speed operations.

Mention the factors that govern the design of field system of alternator.

Number of poles and voltage across each field coil
Amp-turn per pole
Copper loss in field coil
Dissipating surface of field coil
Specific loss dissipation and allowable temperature rise

Mention the different tests that conducted in an induction motor.

No load test or open circuit test
Short circuit test or load test

Give the different runaway speeds for various turbines.

Types of turbines	Run away speed in terms of rated speed
Pelton wheel	1.8 times
Francis turbine	2 to 2.2 times
Kaplan turbine	2.5 to 2.8 times

What are the factors that are affected due to SCR.

Voltage regulation
Stability
Short circuit current
Parallel operation

UNIT V SYNCHRONOUS MACHINES

Output equations – choice of loadings – Design of salient pole machines – Short circuit ratio – shape of pole face – Armature design – Armature parameters – Estimation of air gap length – Design of rotor – Design of damper winding – Determination of full load field mmf – Design of field winding – Design of turbo alternators – Rotor design.

5.1.Introduction

Synchronous machines are AC machines that have a field circuit supplied by an external DC source. Synchronous machines are having two major parts namely stationary part stator and a rotating field system called rotor. In a synchronous generator, a DC current is applied to the rotor winding producing a rotor magnetic field. The rotor is then driven by external means producing a rotating magnetic field, which induces a 3-phase voltage within the stator winding. Field windings are the windings producing the main magnetic field (rotor windings for synchronous machines); armature windings are the windings where the main voltage is induced (stator windings for synchronous machines).

Types of synchronous machines

Hydrogenerators : The generators which are driven by hydraulic turbines are called hydrogenerators. These are run at lower speeds less than 1000 rpm.

Turbogenerators: These are the generators driven by steam turbines. These generators are run at very high speed of 1500rpm or above.

Engine driven Generators: These are driven by IC engines. These are run at a speed less than 1500 rpm. Hence the prime movers for the synchronous generators are Hydraulic turbines, Steam turbines or IC engines

Hydraulic Turbines: Pelton wheel Turbines: Water head 400 m and above

Francis turbines: Water heads up to 380 m

Keplan Turbines: Water heads up to 50 m

Steam turbines: The synchronous generators run by steam turbines are called turbogenerators or turbo alternators. Steam turbines are to be run at very high speed to get higher efficiency and hence these types of generators are run at higher speeds.

Diesel Engines: IC engines are used as prime movers for very small rated generators.

Construction of synchronous machines

- **Salient pole Machines:** These type of machines have salient pole or projecting poles with concentrated field windings. This type of construction is for the machines which are driven by hydraulic turbines or Diesel engines.

- Nonsalient pole or Cylindrical rotor or Round rotor Machines: These machines are having cylindrical smooth rotor construction with distributed field winding in slots. This type of rotor construction is employed for the machine driven by steam turbines.
- Construction of Hydro-generators: These types of machines are constructed based on the water head available and hence these machines are low speed machines. These machines are constructed based on the mechanical consideration. For the given frequency the low speed demands large number of poles and consequently large
- diameter. The machine should be so connected such that it permits the machine to be transported to the site. It is a normal to practice to design the rotor to withstand the centrifugal force and stress produced at twice the normal operating speed.

Stator core:

- The stator is the outer stationary part of the machine, which consists of the outer cylindrical frame called yoke, which is made either of welded sheet steel, cast iron.
- The magnetic path, which comprises a set of slotted steel laminations called stator core pressed into the cylindrical space inside the outer frame. The magnetic path is laminated to reduce eddy currents, reducing losses and heating. CRGO laminations of 0.5 mm thickness are used to reduce the iron losses.
- A set of insulated electrical windings are placed inside the slots of the laminated stator. The cross-sectional area of these windings must be large enough for the power rating of the machine. For a 3-phase generator, 3 sets of windings are required, one for each phase connected in star. Fig. 1 shows one stator lamination of a synchronous generator.
- In case of generators where the diameter is too large stator lamination can not be punched in on circular piece. In such cases the laminations are punched in segments. A number of segments are assembled together to form one circular laminations. All the laminations are insulated from each other by a thin layer of varnish.

Details of construction of stator are shown in Figs 2 –

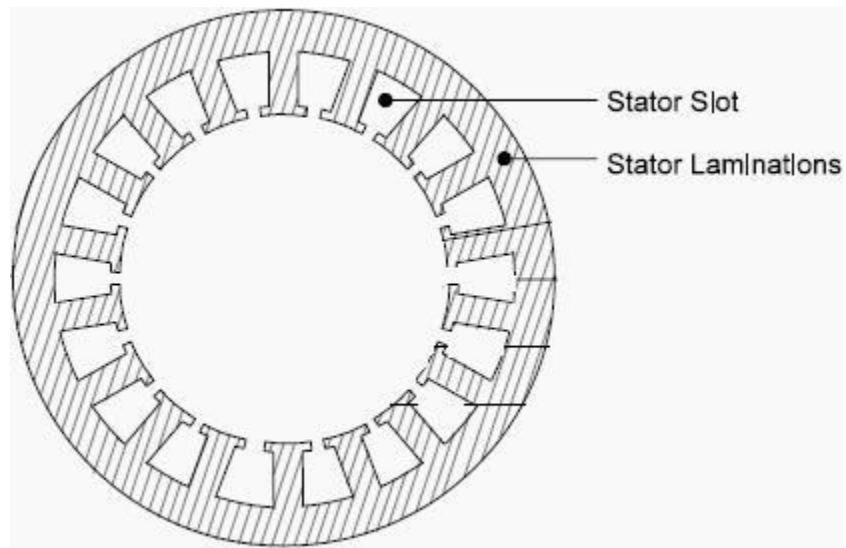

Fig. 1. Stator lamination

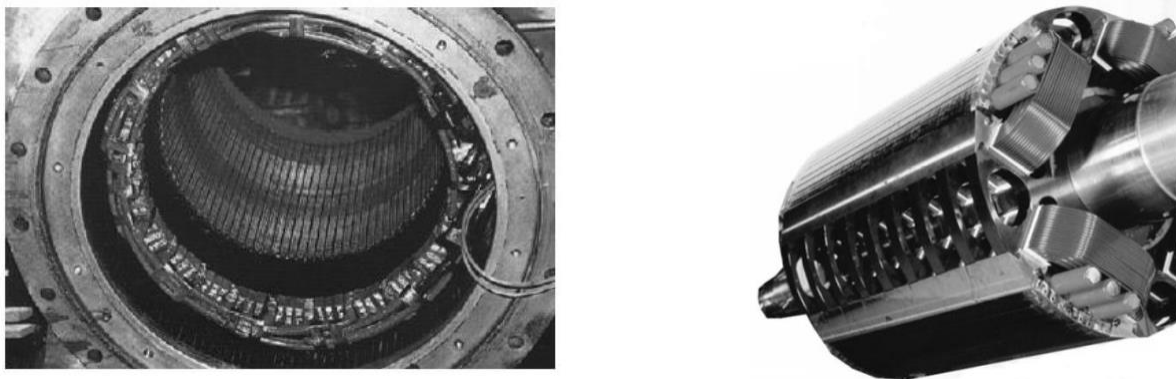

Fig 2. (a) Stator and (b) rotor of a salient pole alternator

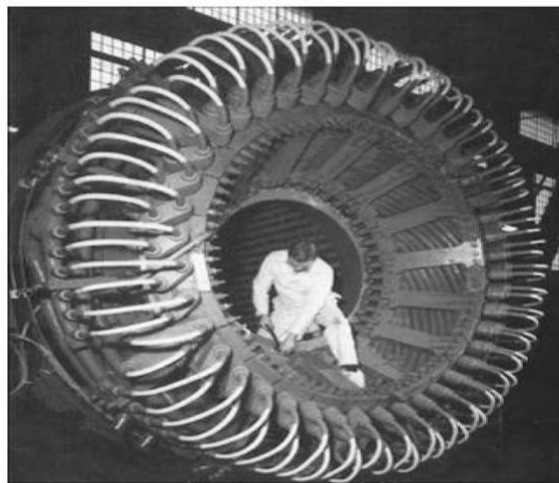

Fig 3. (a) Stator of a salient pole alternator

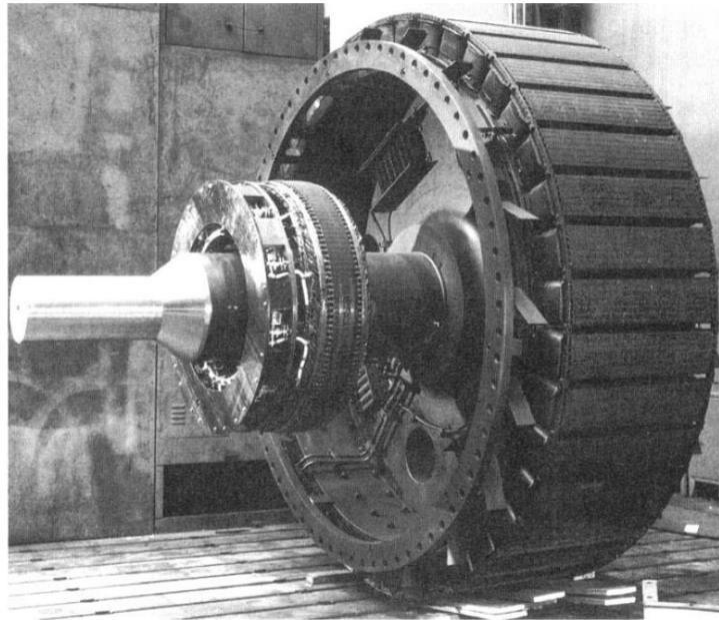

Fig 4. Rotor of a salient pole alternator

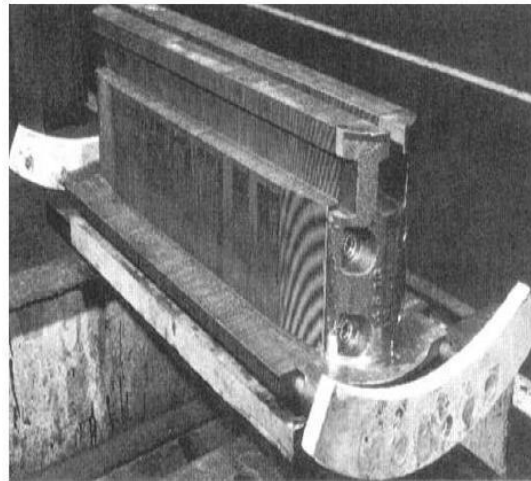

Fig 5. (a) Pole body (b) Pole with field coils of a salient pole alternator

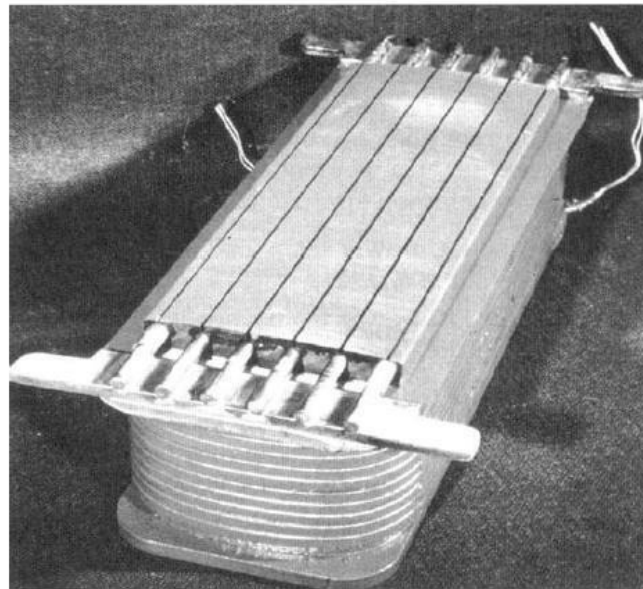

Fig 6. Slip ring and Brushes



Fig 7. Rotor of a Non salient pole alternator

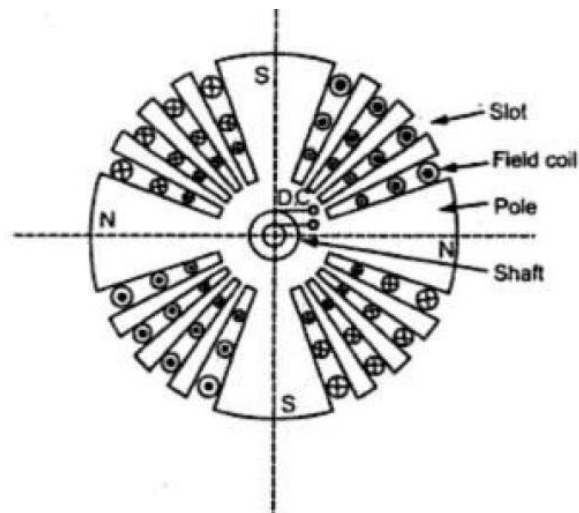

Fig 8. Rotor of a Non salient pole alternator

Rotor of water wheel generator consists of salient poles. Poles are built with thin silicon steel laminations of 0.5mm to 0.8 mm thickness to reduce eddy current laminations. The laminations are clamped by heavy end plates and secured by studs or rivets. For low speed rotors poles have the bolted on construction for the machines with little higher peripheral speed poles have dove tailed construction as shown in Figs. Generally rectangular or round pole constructions are used for such type of alternators. However the round poles have the advantages over rectangular poles. Generators driven by water wheel turbines are of either horizontal or vertical shaft type. Generators with fairly higher speeds are built with horizontal shaft and the generators with higher power ratings and low speeds are built with vertical shaft design. Vertical shaft generators are of two types of designs (i) Umbrella type where in the bearing is mounted below the rotor. (ii) Suspended type where in the bearing is mounted above the rotor.

5.2.Relative dimensions of Turbo and water wheel alternators:

Turbo alternators are normally designed with two poles with a speed of 3000 rpm for a 50 Hz frequency. Hence peripheral speed is very high. As the diameter is proportional to the peripheral speed, the diameter of the high speed machines has to be kept low. For a given volume of the machine when the diameter is kept low the axial length of the machine increases. Hence a turbo alternator will have small diameter and large axial length.

However in case of water wheel generators the speed will be low and hence number of poles required will be large. This will indirectly increase the diameter of the machine. Hence for a given volume of the machine the length of the machine reduces. Hence the water wheel generators will have large diameter and small axial length in contrast to turbo alternators.

Introduction to Design

Synchronous machines are designed to obtain the following information's.

- Main dimensions of the stator frame.
- Complete details of the stator windings.
- Design details of the rotor and rotor winding.
- Performance details of the machine.

To proceed with the design and arrive at the design information the design engineer needs the following information.

- Specifications of the synchronous machine.
- Information regarding the choice of design parameters.
- Knowledge on the availability of the materials.

Limiting values of performance parameters.

Details of Design equations.

5.3. Specifications of the synchronous machine:

Important specifications required to initiate the design procedure are as follows:

Rated output of the machine in kVA or MVA, Rated voltage of the machine in kV, Speed, frequency, type of the machine generator or motor, Type of rotor salient pole or non salient pole, connection of stator winding, limit of temperature, details of prime mover etc.

5.4. Main Dimensions:

Internal diameter and gross length of the stator forms the main dimensions of the machine. In order to obtain the main dimensions it is required to develop the relation between the output and the main dimensions of the machine. This relation is known as the output equation.

5.5. Output equations

Output of the 3 phase synchronous generator is given by

$$\text{Output of the machine } Q = 3V_{ph} I_{ph} \times 10^{-3} \text{ kVA}$$

Assuming Induced emf $E_{ph} = V_{ph}$

$$\text{Output of the machine } Q = 3E_{ph} I_{ph} \times 10^{-3} \text{ kVA}$$

$$\text{Induced emf } E_{ph} = 4.44 f \quad T_{ph} K_w$$

$$= 2.22 f \quad Z_{ph} K_w$$

$$\text{Frequency of generated emf } f = P N_s / 120 = P n_s / 2,$$

Air gap flux per pole = $B_{av} DL/p$, and Specific electric loading $q = 3I_{ph} Z_{ph} / D$

$$\text{Output of the machine } Q = 3 \times (2.22 \times P n_s / 2 \times B_{av} DL/p \times Z_{ph} K_w) I_{ph} \times 10^{-3} \text{ kVA}$$

$$\text{Output } Q = (1.11 \times B_{av} \quad DL \times n_s \times K_w) (3 \times I_{ph} Z_{ph}) \times 10^{-3} \text{ kVA}$$

Substituting the expressions for Specific electric loadings

$$\text{Output } Q = (1.11 \times B_{av} \quad DL \times n_s \times K_w) (D q) \times 10^{-3} \text{ kVA}$$

$$Q = (1.11 \quad D^2 L B_{av} q K_w n_s \times 10^{-3}) \text{ kVA}$$

$$= (11 B_{av} q K_w \times 10^{-3}) D^2 L n_s \text{ kVA}$$

$$\text{Therefore Output } Q = C_o D^2 L n_s \text{ kVA}$$

$$\text{or } D^2 L = Q / C_o n_s^3$$

$$\text{where } C_o = (11 B_{av} q K_w \times 10^{-3})$$

V_{ph} = phase voltage ; I_{ph} = phase current E_{ph} = induced EMF per phase

Z_{ph} = no of conductors/phase in stator

T_{ph} = no of turns/phase

n_s = synchronous speed in rps

p = no of poles, q = Specific electric loading

air gap flux/pole; B_{av} = Average flux density

k_w = winding factor

From the output equation of the machine it can be seen that the volume of the machine is directly proportional to the output of the machine and inversely proportional to the speed of the machine. The machines having higher speed will have reduced size and cost. Larger values of specific loadings smaller will be the size of the machine.

5.6.Choice of Specific loadings:

From the output equation it is seen that choice of higher value of specific magnetic and electric loading leads to reduced cost and size of the machine.

Specific magnetic loading:

Following are the factors which influences the performance of the machine.

Iron loss: A high value of flux density in the air gap leads to higher value of flux in the iron parts of the machine which results in increased iron losses and reduced efficiency.

Voltage: When the machine is designed for higher voltage space occupied by the insulation becomes more thus making the teeth smaller and hence higher flux density in teeth and core.

Transient short circuit current: A high value of gap density results in decrease in leakage reactance and hence increased value of armature current under short circuit conditions.

Stability: The maximum power output of a machine under steady state condition is indirectly proportional to synchronous reactance. If higher value of flux density is used it leads to smaller number of turns per phase in armature winding. This results in reduced value of leakage reactance and hence increased value of power and hence increased steady state stability.

Parallel operation: The satisfactory parallel operation of synchronous generators depends on the synchronizing power. Higher the synchronizing power higher will be the ability of the machine to operate in synchronism. The synchronizing power is inversely proportional to the synchronous reactance and hence the machines

Specific Electric Loading:

Following are the some of the factors which influence the choice of specific electric loadings.

Copper loss: Higher the value of q larger will be the number of armature of conductors which results in higher copper loss. This will result in higher temperature rise and reduction in efficiency.

Voltage: A higher value of q can be used for low voltage machines since the space required for the insulation will be smaller.

Synchronous reactance: High value of q leads to higher value of leakage reactance and armature reaction and hence higher value of synchronous reactance. Such machines will have poor voltage regulation, lower value of current under short circuit condition and low value of steady state stability limit and small value of synchronizing power.

Stray load losses: With increase of q stray load losses will increase. Values of specific magnetic and specific electric loading can be selected from Design Data Hand Book for salient and non salient pole machines.

Separation of D and L: Inner diameter and gross length of the stator can be calculated from D^2L product obtained from the output equation. To separate suitable relations are assumed between D and L depending upon the type of the generator. **Salient pole machines:** In case of salient pole machines either round or rectangular pole construction is employed. In these types of machines the diameter of the machine will be quite larger than the axial length.

Round Poles: The ratio of pole arc to pole pitch may be assumed varying between 0.6 to 0.7 and pole arc may be taken as approximately equal to axial length of the stator core. Hence Axial length of the core/ pole pitch = $L/p = 0.6$ to 0.7 **Rectangular poles:** The ratio of axial length to pole pitch may be assumed varying between 0.8 to 3 and a suitable value may be assumed based on the design specifications.

Axial length of the core/ pole pitch = $L/p = 0.8$ to 3 Using the above relations D and L can be separated. However once these values are obtained diameter of the machine must satisfy the limiting value of peripheral speed so that the rotor can withstand centrifugal forces produced. Limiting values of peripheral speeds are as follows:

Bolted pole construction = 45 m/s

Normal design = 30 m/s

5.7. Design of salient pole machines

These type of machines have salient pole or projecting poles with concentrated field windings. This type of construction is for the machines which are driven by hydraulic turbines or Diesel engines.

Rotor of water wheel generator consists of salient poles. Poles are built with thin silicon steel laminations of 0.5mm to 0.8 mm thickness to reduce eddy current laminations. The laminations are clamped by heavy end plates and secured by studs or rivets. For low speed rotors poles have the bolted on construction for the machines with little higher peripheral speed poles have dove tailed construction as shown in Figs. Generally rectangular or round pole constructions are used for such type of alternators. However the round poles have the advantages over rectangular poles.

In case of salient pole machines either round or rectangular pole construction is employed. In these types of machines the diameter of the machine will be quite larger than the axial length.

Round Poles: The ratio of pole arc to pole pitch may be assumed varying between 0.6 to 0.7 and pole arc may be taken as approximately equal to axial length of the stator core. Hence

Axial length of the core/ pole pitch = $L/\tau_p = 0.6$ to 0.7

Rectangular poles: The ratio of axial length to pole pitch may be assumed varying between 0.8 to 3 and a suitable value may be assumed based on the design specifications.

Axial length of the core/ pole pitch = $L/\tau_p = 0.8$ to 3

Using the above relations D and L can be separated. However once these values are obtained diameter of the machine must satisfy the limiting value of peripheral speed so that the rotor can withstand centrifugal forces produced. Limiting values of peripheral speeds are as follows:

Bolted pole construction = 45 m/s Dove tail pole construction = 75 m/s Normal design = 30

m/s 5.8. Short circuit ratio

It is defined as the ratio of field current required to produce rated voltage on open circuit to the field current reqd. to circulate rated current on short circuit.

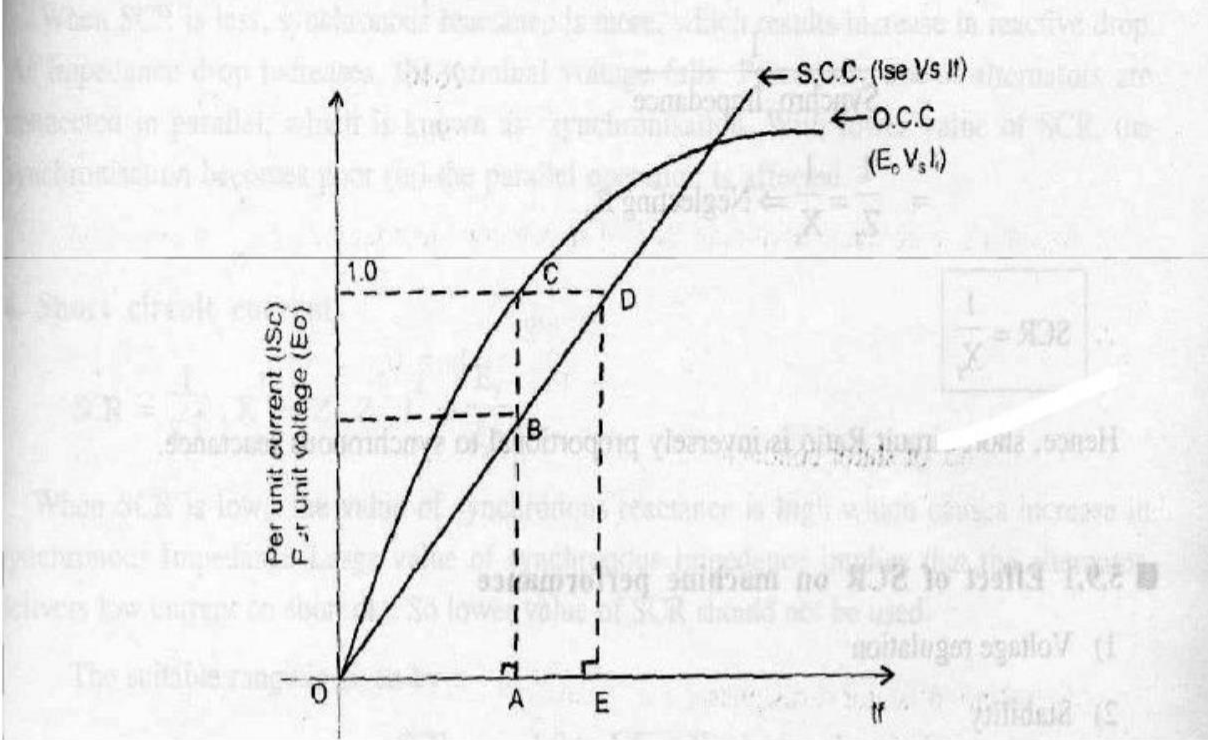

Explanation

The fig shows open Circuit and short Circuit characteristics of an alternator.

According to definition,

$$\text{SCR} = \frac{OA}{OE}$$

Triangles OAB and OED are similar

Since $\frac{OA}{OB} = \frac{OE}{OD}$

$$\frac{OA}{OB} = \frac{OE}{OD}$$

$$\frac{OA}{OB} = \frac{OE}{OD}$$

Now, $\frac{OA}{OE} = \frac{AB}{ED} = \frac{OB}{OD}$

$$\therefore \text{SCR} = \frac{AB}{ED}$$

$$\begin{aligned}
 &= \frac{AB}{AC} \Rightarrow \frac{1}{\left(\frac{AC}{AB}\right)} \Rightarrow \frac{1}{\frac{\text{open ckt voltage}}{\text{short ckt. current}}} \\
 &= \frac{1}{\text{Synchro Impedance}} \\
 &= \frac{1}{Z_s} = \frac{1}{X_s} \Rightarrow \text{Neglecting } R_a
 \end{aligned}$$

Effect of SCR on Machine performance

Voltage regulation

Stability

Parallel operation

Short circuit Current

Cost and size of the machine

1. Voltage Regulation

2. Stability

$$\begin{aligned}
 \downarrow \text{SCR} = \frac{1}{X_s \uparrow}, P_{\text{Syn. Max}} \downarrow &\Rightarrow \frac{EV}{X_s \uparrow}, P_{\text{Syn. Max}} \downarrow \Rightarrow \text{Stability} \downarrow
 \end{aligned}$$

3 Parallel operation: SCR = 1/ Xs, as SCR Xs IXs V Psync

4. Short circuit current

$$\text{SCR} = \frac{1}{X_s^\uparrow}, X_s^\uparrow \Rightarrow Z_s^\uparrow, Z_s^\uparrow, I_{sc}^\downarrow = \frac{E_s}{Z_s^\downarrow}$$

5. Size and cost of the machine as SCR X_s Z_s I_{sc} and hence cost of control equipment reduces

For salient pole machines SCR value varies from 0.9 to 1.3

For turbo alternators SCR value varies from 0.7 to 1.1

5.9.Length of the air gap:

Length of the air gap is a very important parameter as it greatly affects the performance of the machine. Air gap in synchronous machine affects the value of SCR and hence it influences many other parameters. Hence, choice of air gap length is very critical in case of synchronous machines.

Following are the advantages and disadvantages of larger air gap.

Advantages:

- Stability: Higher value of stability limit
- Regulation: Smaller value of inherent regulation
- Synchronizing power: Higher value of synchronizing power
- Cooling: Better cooling
- Noise: Reduction in noise
- Magnetic pull: Smaller value of unbalanced magnetic pull

Disadvantages:

- Field MMF: Larger value of field MMF is required
- Size: Larger diameter and hence larger size
- Magnetic leakage: Increased magnetic leakage
- Weight of copper: Higher weight of copper in the field winding
- Cost: Increase overall cost.

Hence length of the air gap must be selected considering the above factors.

5.10. shape of pole face

Stator slots: in general two types of stator slots are employed in induction motors viz, open slots and semiclosed slots. Operating performance of the induction motors depends upon the shape of the slots and hence it is important to select suitable slot for the stator slots.

Open slots: In this type of slots the slot opening will be equal to that of the width of the slots as shown in Fig. In such type of slots assembly and repair of winding are easy. However such slots will lead to higher air gap contraction factor and hence poor power factor. Hence these types of slots are rarely used in 3Φ synchronous motors.

Semiclosed slots: In such type of slots, slot opening is much smaller than the width of the slot as shown in Figs. Hence in this type of slots assembly of windings is more difficult and takes more time compared to open slots and hence it is costlier. However the air gap characteristics are better compared to open type slots.

Tapered slots: In this type of slots also, opening will be much smaller than the slot width. However the slot width will be varying from top of the slot to bottom of the slot with minimum width at the bottom as shown in Fig

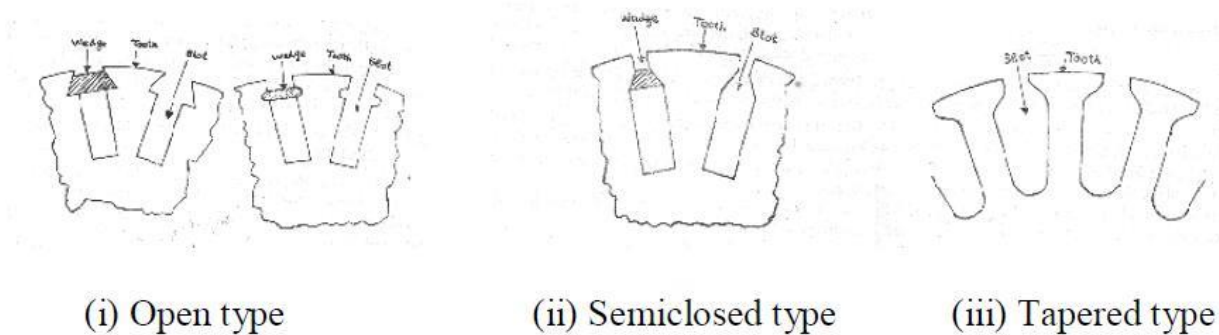

(i) Open type

(ii) Semiclosed type

(iii) Tapered type

5.11. Armature design

Armature windings are rotating-field windings, into which the rotating-field-induced voltage required in energy conversion is induced. According to IEC 60050-411, the armature winding is a winding in a synchronous machine, which, in service, receives active power from or delivers active power to the external electrical system. This definition also applies to a synchronous compensator if the term ‘active power’ is replaced by ‘reactive power’. The air-gap flux component caused by the armature current linkage is called the armature reaction.

An armature winding determined under these conditions can transmit power between an electrical network and a mechanical system. Magnetizing windings create a magnetic field required in the energy conversion. All machines do not include a separate magnetizing winding; for instance, in asynchronous machines, the stator winding both magnetizes the machine and acts as a winding, where the operating voltage is induced. The stator winding of an asynchronous machine is similar to the armature of a synchronous machine; however, it is not defined as an armature in the IEC standard. In this material, the asynchronous machine stator is therefore referred to as a rotating-field stator winding, not an armature

DESIGN OF ELECTRICAL APPARATUS winding. Voltages are also induced in the rotor of an asynchronous machine, and currents that are significant in torque production are created. However, the rotor itself takes only a rotor's dissipation power (I^2R) from the air-gap power of the machine, this power being proportional to the slip;

5.12. Armature parameters

- Number of Slots
- Turns per phase
- Single turn bar windings
- Dimensions
- Depth
- Mean length

5.13. Estimation of air gap length

Length of the air gap is usually estimated based on the ampere turns required for the air gap. Armature ampere turns per pole required $AT_a = 1.35 T_{ph} k_w / p$

Where T_{ph} = Turns per phase, I_{ph} = Phase current, k_w = winding factor, p = pairs of poles
 No load field ampere turns per pole $AT_{fo} = SCR \times$ Armature ampere turns per pole
 $AT_{fo} = SCR \times AT_a$

Suitable value of SCR must be assumed.

Ampere turns required for the air gap will be approximately equal to 70 to 75 % of the no load field ampere turns per pole.

$$AT_g = (0.7 \text{ to } 0.75) AT_{fo}$$

$$\text{Air gap ampere turns } AT_g = 796000 B_g k_g l_g$$

Air gap coefficient or air gap contraction factor may be assumed varying from 1.12 to 1.18.

As a guide line, the approximate value of air gap length can be expressed in terms of pole pitch

$$\text{For salient pole alternators: } l_g = (0.012 \text{ to } 0.016) \times \text{pole pitch}$$

$$\text{For turbo alternators: } l_g = (0.02 \text{ to } 0.026) \times \text{pole pitch}$$

Synchronous machines are generally designed with larger air gap length compared to that of Induction motors.

5.14. Design of rotor

There are two types of rotor construction. One is the squirrel cage rotor and the other is the slip ring rotor. Most of the induction motor are squirrel cage type. These are having the advantage of rugged and simple in construction and comparatively cheaper. However they have the disadvantage of lower starting torque. In this type, the rotor consists of bars of copper or aluminum accommodated in rotor slots. In case slip ring induction motors the rotor complex in construction and costlier with the advantage that

EE8002 DESIGN OF ELECTRICAL APPARATUS they have the better starting torque. This type of rotor consists of star connected distributed three phase

windings. Between stator and rotor is the air gap which is a very critical part. The performance parameters of the motor like magnetizing current, power factor, over load capacity, cooling and noise are affected by length of the air gap. Hence length of the air gap is selected considering the advantages and disadvantages of larger air gap length.

Advantages:

- Increased overload capacity
- Increased cooling
- Reduced unbalanced magnetic pull
- Reduced in tooth pulsation
- Reduced noise

Disadvantages

- Increased Magnetising current
- Reduced power factor

5.15. Design of damper winding

Damper windings are provided in the pole faces of salient pole alternators. Damper windings are nothing but the copper or aluminum bars housed in the slots of the pole faces.

The ends of the damper bars are short circuited at the ends by short circuiting rings similar to end rings as in the case of squirrel cage rotors.

These damper windings are serving the function of providing mechanical balance; provide damping effect, reduce the effect of over voltages and damp out hunting in case of alternators. In case of synchronous motors they act as rotor bars and help in self starting of the motor.

5.16. Determination of full load field MMF

Full load field mmf can be taken as twice the armature mmf.

$$AT_{fl} = 2 \times AT_a = 2 \times 1.35 \times I_{ph} \times T_{ph} \times k_w / p$$

5.17. Design of field winding

Stator winding is made up of former wound coils of high conductivity copper of diamond shape. These windings must be properly arranged such that the induced emf in all the phases of the coils must have the same magnitude and frequency. These emfs must have same wave shape and be displaced by 120° to each other. Single or double layer windings may be used depending on the requirement. The three phase windings of the synchronous machines are always connected in star with neutral earthed. Star

EE8002 DESIGN OF ELECTRICAL APPARATUS connection of windings eliminates the 3rd harmonics from the line emf. Double layer winding: Stator

windings of alternators are generally double layer lap windings either integral slot or fractional slot windings. Full pitched or short chorded windings may be employed. Following are the advantages and disadvantages of double layer windings.

Advantages:

Better waveform: by using short pitched coil

Saving in copper: Length of the overhang is reduced by using short pitched coils

Lower cost of coils: saving in copper leads to reduction in cost

Fractional slot windings: Only in double layer winding, leads to improvement in waveform

Disadvantages:

Difficulty in repair: difficult to repair lower layer coils

Difficulty in inserting the last coil: Difficulty in inserting the last coil of the windings

Higher Insulation: More insulation is required for double layer winding

Wider slot opening: increased air gap reluctance and noise

Number of Slots:

The number of slots are to be properly selected because the number of slots affect the cost and performance of the machine. There are no rules for selecting the number of slots. But looking into the advantages and disadvantages of higher number of slots, suitable number of slots per pole per phase is selected. However the following points are to be considered for the selection of number of slots.

Advantages:

Reduced leakage reactance

Better cooling

Decreased tooth ripples

Disadvantages:

Higher cost

Teeth becomes mechanically weak

Higher flux density in teeth

Slot loading must be less than 1500 ac/slot

Slot pitch must be with in the following limitations

(i) Low voltage machines __3.5 cm

(ii) Medium voltage machines up to 6kV __ 5.5 cm

(iv) High voltage machines up to 15 kV __ 7.5 cm

Considering all the above points number of slots per pole phase for salient pole machines may be taken as 3 to 4 and for turbo alternators it may be selected as much higher of the order of 7 to 9 slots per pole per phase. In case of fractional slot windings number of slots per pole per phase may be selected as fraction 3.5.

Turns per phase:

Turns per phase can be calculated from emf equation of the alternator.

- Induced emf $E_{ph} = 4.44 f T_{ph} K_w$
- Hence turns per phase $T_{ph} = E_{ph} / 4.44 f K_w$
- E_{ph} = induced emf per phase
- Z_{ph} = no of conductors/phase in stator
- T_{ph} = no of turns/phase
- k_w = winding factor may assumed as 0.955

Conductor cross section: Area of cross section of stator conductors can be estimated from the stator current per phase and suitably assumed value of current density for the stator windings.

Sectional area of the stator conductor as $= I_s / s$ where s is the current density in stator windings I_s is stator current per phase. A suitable value of current density has to be assumed considering the advantages and disadvantages.

Advantages of higher value of current density:

- reduction in cross section
- reduction in weight
- reduction in cost

Disadvantages of higher value of current density

- increase in resistance
- increase in cu loss
- increase in temperature rise
- reduction in efficiency

Hence higher value is assumed for low voltage machines and small machines. Usual value of current density for stator windings is 3 to 5 amps/mm².

Stator coils:

Two types of coils are employed in the stator windings of alternators. They are single turn bar coils and multi turn coils. Comparisons of the two types of coils are as follows

Multi turn coil winding allows greater flexibility in the choice of number of slots than single turn bar coils.

Multi turn coils are former wound or machine wound where as the single turn coils are hand made.

Bending of top coils is involved in multi turn coils where as such bends are not required in single turn coils.

Replacing of multi turn coils difficult compared to single turn coils.

Machine made multi turn coils are cheaper than hand made single turn coils.

End connection of multi turn coils are easier than soldering of single turn coils.

Full transposition of the strands of the single turn coils are required to eliminate the eddy current loss.

Each turn of the multi turn winding is to be properly insulated thus increasing the amount of insulation and reducing the space available for the copper in the slot.

From the above discussion it can be concluded that multi turn coils are to be used to reduce the cost of the machine. In case of large generators where the stator current exceeds 1500 amps single turn coils are employed.

Single turn bar windings:

The cross section of the conductors is quite large because of larger current. Hence in order to eliminate the eddy current loss in the conductors, stator conductors are to be stranded. Each slot of the stator conductor consists of two stranded conductors as shown in Fig .he dimensions of individual strands are selected based on electrical considerations and the manufacturing requirements. Normally the width of the strands is assumed between 4 mm to 7 mm. The depth of the strands is limited based on the consideration of eddy current losses and hence it should not exceed 3mm. The various strand of the bar are transposed in such a way as to minimize the circulating current loss.

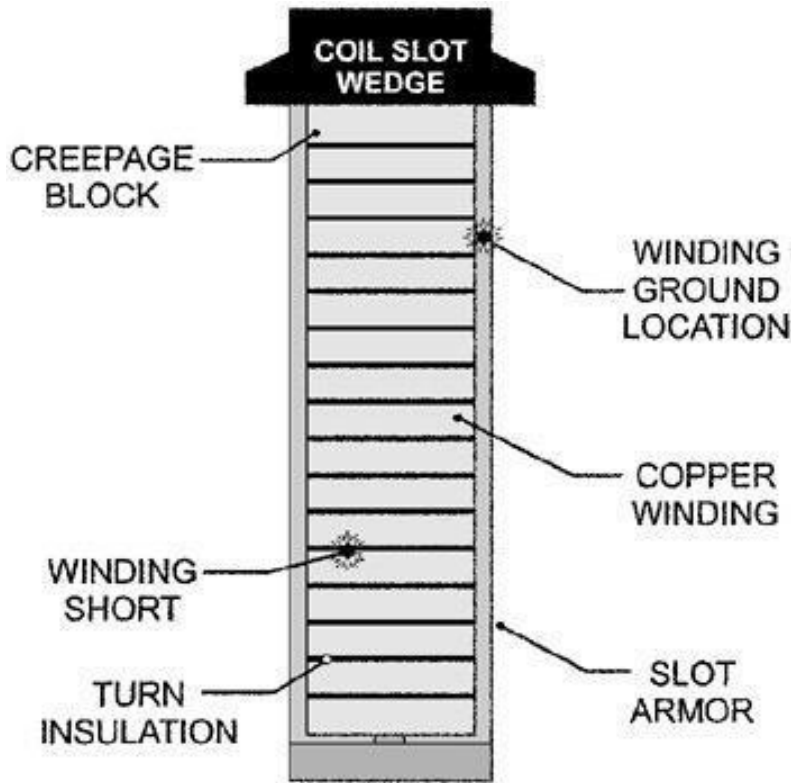

Multi turn coils:

Multi turn coils are former wound. These coils are made up of insulated high conductivity copper conductors. Mica paper tape insulations are provided for the portion of coils in the slot and varnished mica tape or cotton tape insulation is provide on the overhang portion. The thickness of insulation is decided based on the voltage rating of the machine. Multi turn coils are usually arranged in double layer windings in slots as shown in Fig.

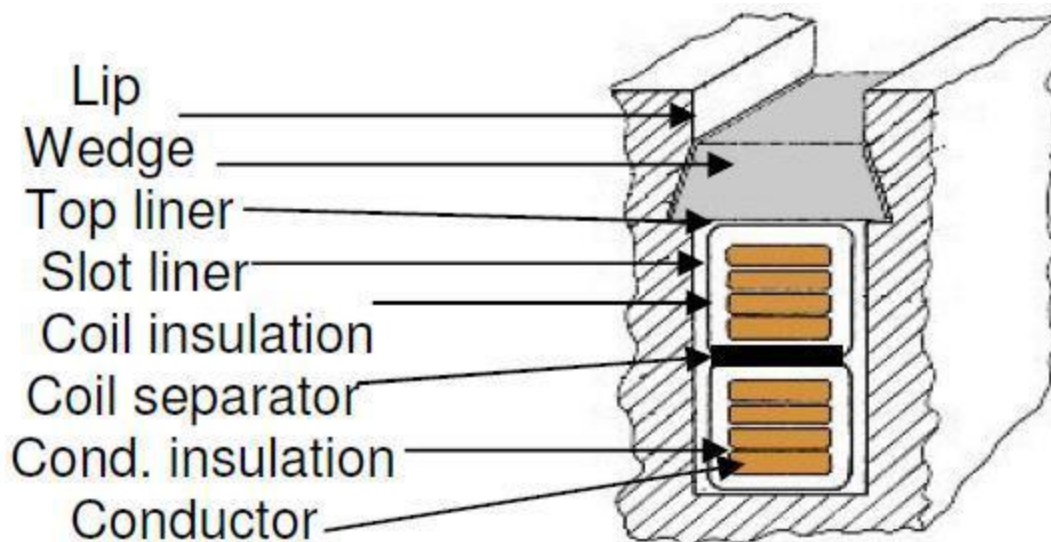

Dimensions of stator slot:

Width of the slot = slot pitch – tooth width

The flux density in the stator tooth should not exceed 1.8 to 2.0 Tesla. In salient pole alternators internal diameter is quite large and hence the flux density along the depth of the tooth does not vary appreciably. Hence width of the tooth may be estimated corresponding to the permissible flux density at the middle section of the tooth. The flux density should not exceed 1.8 Tesla. However in case of turbo alternators variation of flux density along the depth of the slot is appreciable and hence the width of the tooth may be estimated corresponding to the flux density at the top section of the tooth or the width of the tooth at the air gap. The flux density at this section should not exceed 1.8 Tesla.

For salient pole alternator:

Flux density at the middle section = Flux / pole / (width of the tooth at the middle section x iron length x number of teeth per pole arc)

Number of teeth per pole arc = pole arc/slot pitch

For turbo alternators:

Flux density at the top section = Flux / pole / (width of the tooth at the top section x iron length x number of teeth per pole pitch)

As the 2/3rd pole pitch is slotted the number of teeth per pole pitch = 2/3 x pole pitch/ (slot pitch at top section)

Slot width = slot pitch at the top section – tooth width at the top section.

Once the width of the slot is estimated the insulation required width wise and the space available for conductor width wise can be estimated.

Slot insulation width wise:

Conductor insulation

Mica slot liner

Binding tape over the coil

Tolerance or clearance

Space available for the conductor width wise = width of the slot – insulation width wise We have already calculated the area of cross section of the conductor. Using above data on space available for the conductor width wise depth of the conductor can be estimated. Now the depth of the slot may be estimated as follows.

Depth of the slot:

Space occupied by the conductor = depth of each conductor x no. of conductor per slot

Conductor insulation

Mica slot liner

Mica or bituminous layers to separate the insulated conductors

Coil separator between the layers

Wedge

Lip

Tolerance or clearance

Mean length of the Turn:

The length of the mean turn depends on the following factors

Gross length of the stator core: Each turn consists of two times the gross length of stator core.

Pole pitch: The over hang portion of the coils depend upon the coil span which in turn depends upon the pole pitch.

Voltage of the machine: The insulated conductor coming out of the stator slot should have straight length beyond the stator core which depends upon the voltage rating of the machine.

Slot dimension: Length per turn depends on the average size of the slot. Hence mean length of the turn in double layer windings of synchronous machines is estimated as follows.

$$l_{mt} = 2l + 2.5 p + 5 kV + 15 \text{ cm}$$

Design of turbo alternators

Turbo alternators: These alternators will have larger speed of the order of 3000 rpm. Hence the diameter of the machine will be smaller than the axial length. As such the diameter of the rotor is limited from the consideration of permissible peripheral speed limit. Hence the internal diameter of the stator is normally calculated based on peripheral speed. The peripheral speed in case of turbo alternators is much higher than the salient pole machines. Peripheral speed for these alternators must be below 175 m/s.

PROBLEMS

EX.1. Design the stator frame of a 500 kVA, 6.6 kV, 50 Hz, 3 phase, 12 pole, star connected salient pole alternator, giving the following informations.

Internal diameter and gross length of the frame

Number of stator conductors

(iii) Number of stator slots and conductors per slot

Specific magnetic and electric loadings may be assumed as 0.56 Tesla and 26000 Ac/m respectively.

Peripheral speed must be less than 40 m/s and slot must be less than 1200.

EX.2. A 3 phase 1800 kVA, 3.3 kV, 50 Hz, 250 rpm, salient pole alternator has the following design data.

Stator bore diameter = 230 cm

Gross length of stator bore = 38 cm

(iii) Number of stator slots = 216

Number of conductors per slot = 4

Sectional area of stator conductor = 86 mm²

Using the above data, calculate

Flux per pole

Flux density in the air gap

Current density

Size of stator slot

EX.3. A water wheel generator with power output of 4750 kVA, 13.8 kV, 50 Hz, 1000 rpm, working at a pf of 0.8 has a stator bore and gross core length of 112 cm and 98 cm respectively. Determine the loading constants for this machine.

Using the design constants obtained from the above machine determine the main dimensions of the water wheel generator with 6250 kVA, 13.8 kV, 50 Hz, 750 rpm operating at a power factor of 0.85. Also determine (i) Details of stator winding (ii) Size of the stator slot, (iii) Copper losses in the stator winding.

EX.4. Two preliminary designs are made for a 3 phase alternator, the two designs differing only in number and size of the slots and the dimensions of the stator conductors. The first design uses two slots per pole per phase with 9 conductors per slot, each slot being 75 mm deep and 19 mm wide, the mean width of the stator tooth is 25 mm. The thickness of slot insulation is 2 mm, all other insulation may be neglected. The second design is to have 3 slots per pole per phase. Retaining the same flux density in the teeth and current density in the stator conductors as in the first design, calculate the dimensions of the stator slot for the second design. Total height of lip and wedge may be assumed as 5 mm.

- EX.5. A 1000 kVA, 3300 volts, 50 Hz, 300 rpm, 3 phase alternator has 180 slots with 5 conductors per slot. Single layer winding with full pitched coils is used. The winding is star connected with one circuit per phase. Determine the specific electric and magnetic loading if the stator bore is 2 m and core length is 0.4 m. Using the same specific loadings determine the design details for a 1250 kVA, 3300 volts, 50 Hz, 250 rpm, 3 phase star connected alternator having 2 circuits per phase. The machines have 60° phase spread.
- EX.6. Determine the main dimensions of a 75 MVA, 13.8 kV, 50 Hz, 62.5 rpm, 3 phase star connected alternator. Also find the number of stator slots, conductors per slot, conductor area and work out the winding details. The peripheral speed should be less than 40 m/s. Assume average gap density as 0.65 wb/m², Specific electric loading as 40,000 AC/m and current density as 4 amp/mm².
- EX.7. Calculate the stator dimensions for 5000 kVA, 3 phase, 50 Hz, 2 pole alternator. Take mean gap density of 0.5 wb/m², specific electric loading of 25,000 ac/m, peripheral velocity must not exceed 100 m/s. Air gap may be taken as 2.5 cm.

QUESTION BANK**Unit-V SYNCHRONOUS MACHINES****Advantages of stationary armature and rotating field type machine.**

Since armature winding is stationary the load circuit can be directly connected to it.

As the armature winding is fixed it is easy to provide insulation for high Voltages.

Weight of field system is less as compared to armature so that higher speed can be achieved.

Since the exciter supplies low voltage d.c. it requires less amount of insulation.

Define critical speed?

The rotor of an alternator rotates with prime mover speed. The rotor core is structure which has certain mass and property of elasticity. The rotor core is designed corresponding to natural frequency is called critical speed.

Give the importance of compensating winding in dc machine.

It is provided in pole shoe.

It is connected in series with armature winding.

It is used to reduce armature reaction.

Due to this winding full range of speed variation can be obtained.

Mention superiority of hydrogen over air as coolant?

Heat transfer co-efficient of hydrogen is 1.5 times that of air.

Thermal conductivity of hydrogen is 7 times that of air.

Density of hydrogen is 0.07 times that of air.

Why deep bar rotor construction is preferred in squirrel cage induction motor?

It is preferable when high starting torque is required. Because loose bars can be damaged quickly by mechanical vibration and thermal cycling.

6. What is varnish impregnation?

The dipping of insulating material into varnish to improve the resistance to moisture and creeping discharge is called varnish impregnation.

How to reduce the harmonic effects?

Short pitch winding

Distributed winding

Fractional slot winding

Large air gap length

Define heating time constant of the machine.

The time taken by the machine to rise its temperature 63.2% of its final steady value.

What are the types of stator winding?

Single layer winding

Double layer winding

Why is it necessary to eliminate voids or air packets in high voltage multi lunch coils?

Since the voids carry air and air has poor thermal conductivity heat transfer will be poor.

Hence voids should be eliminated.

Classify synchronous machines.

Salient pole machine

Cylindrical rotor machine

List the advantages of revolving field system.

The advantages are

It permits the use of a stationary armature on which the windings can be easily braced and insulated for high voltage.
The operation of slip rings on account of their sliding contact is under liable with large currents at high potential difference. The use of slip ring carrying large currents at high voltage is therefore avoided in the stationary armature construction.

Where C_0 = output co-efficient

$$1.11 \Pi^2 B_{av} ac K_{ws} 10^{-3}$$

= KVA output for alternator and KVA input for synchronous motor. D
= Diameter of stator core, m
L = Length of stator core, m
 n_s = Synchronous speed, rps
 B_{av} = Specific magnetic loading, wb/m²
ac = Specific electric loading, amp.cond/m
 K_{ws} = stator winding factor

Mention the factors to be considered for the selection of number of armature slots?

- Balanced windings
- Cost
- Hot spot temperature in winding
- Leakage reaction
- Tooth losses
- Tooth flux density

What are the types of coils employed by the salient pole machines?

- Single turn bar
- Multi turn

How are iron and friction losses of an alternator measured?

Iron and friction losses of an alternator can be measured by coupling the alternator to a suitable calibrated d.c. motor and driving it at synchronous speed with normal excitation. Then,

$$\text{Iron and Friction Losses} = \text{Output of motor in Watts.}$$

17. Is the efficiency of an alternator determined by direct loading?

As with d.c. machines, the efficiency of an alternator is not determined by direct loading owing to the difficulty in finding a suitable load. The efficiency is generally determined from losses.

18. Draw a block representing the analysis method of design.

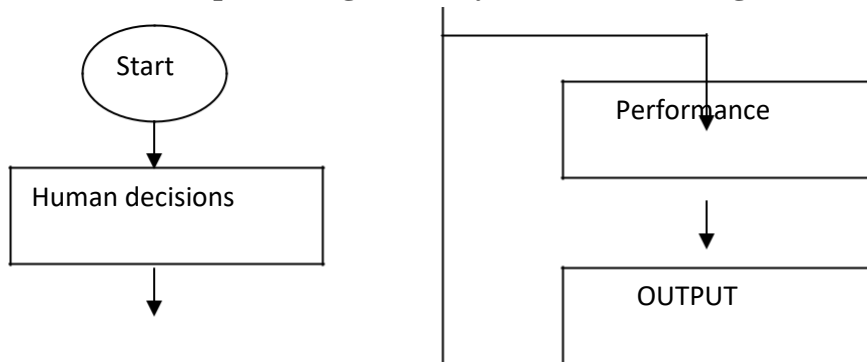

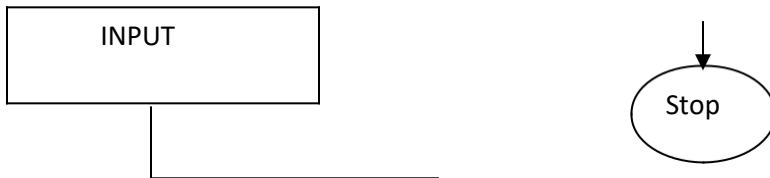

Mention the advantages of analysis

method. The advantages are

- It is fairly easy to program, to use and to understand
- Results in considerable time saving thereby giving quick returns of the investments made.
- The programs based upon analysis methods are simple but they become the foundations for later day larger and sophisticated programs.
- The results of analysis method are highly acceptable by designers.

What is the length of mean turn of the armature?

The length of mean turn of the armature is

$$L_{mt} = 2L + 2.5\tau + 0.06KV + 0.2 \text{ in metre}$$

Where 2L is the length of turn embedded in the slots

$$L_{mt} = 2.5\tau + 0.06KV + 0.2 \text{ in metre}$$

Is the length in the overhang.

21. What is the limiting factor for the diameter of synchronous machine?

The limiting factor for the diameter of synchronous machine is the peripheral speed. The limiting value of peripheral speed is 175 m/sec for cylindrical rotor machines and 80 m/sec for salient pole machines.

22. Write the expression to calculate the height of field winding.

$$h_f = \frac{AT_{fl} * 10^{-4}}{\text{SQRT} (S_f d_f q_f)}$$

Where AT_{fl} is the full load field mmf

S_f is copper space factor

d_f is depth of winding

q_f is loss per unit surface w/m^2

23. What is the total space required for field winding?

$$\text{Total space required for field winding} = \frac{\text{Copper Area}}{\text{Space Factor}}$$

Give the expression to calculate the area of pole bodies.

Area of cross section of rectangular poles $A_p = 0.98 L_p b_p$

Area of cross section of circular poles $A_p = (\pi / 4) b_p^2$.

How is the copper area of field winding calculated?

$$\text{Copper area of field winding} = \frac{\text{Full load field mmf}}{\text{Current density in the field winding}}$$

$$AT_{fl} / \delta_f$$

The value of δ_f lies between 3 to 4 A/mm^2 .

26. What are the advantages of synthesis method?

The greatest advantage of synthesis method is the savings in time in lapsed time and in engineering man hours on account of the decision making left to the computer itself.

35. What is runaway speed?

The runaway speed is defined as the speed which the prime mover would have, if it is suddenly unloaded, when working at its rated load.

State the important features of turbo-alternators.

The rotors of turbo-alternators have large axial length and small diameters. Damping torque is provided by the rotor itself and so there is no necessity for additional damper winding. They are suitable for high speed operations and so number of poles is usually 2 or 4.

What are the prime movers used for a) salient pole alternator b) Non-salient pole alternator?

The prime movers used for salient pole alternators are water wheels like Kaplan turbine, Francis turbine, pelton wheel, etc., and diesel or petrol engines.

The prime movers used for Non-salient pole alternators are steam turbines and gas turbines.

Distinguish between cylindrical pole and salient pole construction.

In cylindrical pole construction the rotor is made of solid cylinder and slots are cut on the outer periphery of the cylinder to accommodate field conductors.

In salient pole construction, the circular or rectangular poles are mounted on the outer surface of a cylinder. The field coils are fixed on the pole.

The cylindrical pole construction is suitable for high speed operations, whereas the salient pole construction is suitable for the slow speed operations.

39. Salient pole alternators are not suitable for high speeds. Why?

The salient pole rotors cannot withstand the mechanical stresses developed at high speeds. The projecting poles may be damaged due to mechanical stresses.

40. State the factors for separation of D and L for cylindrical rotor machine.

The separation of D and L in cylindrical rotor machine depends on the following factors:
Peripheral speed
Number of poles
Short circuit ratio (SCR)

Define pitch factor.

$$\text{Pitch factor } K_c = \frac{\text{Vector sum of emf induced in a coil}}{\text{Arithmetic sum of emf induced in the coil}}$$

42. Define distribution factor.

$$\text{Distribution factor } K_d = \frac{\text{Vector sum of emfs induced in the conductors of a phase Under a pole}}{\text{Arithmetic sum of emfs induced in the conductors of a Phase under a pole}}$$

Mention the advantages of fractional slot winding.

In low speed machines with large number of poles, the fractional slot winding will reduce tooth harmonics. A range of machines with different speeds can be designed with a single lamination. The fractional slot winding reduces the harmonics in mf and the leakage reactance of the windings. The fractional slot winding allows only short chorded winding. Therefore the length of mean turn of a coil reduces which results in shorter end connections and so saving in copper.

What is short circuit ratio (SCR)?

The Short circuit ratio (SCR) is defined as the ratio of field current required to produce rated voltage on open circuit to field current required to circulate rated current at short circuit.

It is also given by the reciprocal of synchronous reactance, X_d in p.u.

For turbo-alternators SCR is between 0.5 to 0.7.

For salient pole alternator SCR varies from 1.0 to 1.5

List the factors to be considered for the choice of specific electric loading in synchronous machines.

- Copper loss
- Temperature rise
- Synchronous reactance
- Stray load losses
- Voltage rating

Determine the total number of slots in the stator of an alternator having 4 poles, 3 phase, 6 slots per pole for each phase?

Total number of slots = slots/pole/phase * number of poles * Number of phases

$$6*4*3$$

72 slots.

How the value of SCR affects the design of alternator.

For high stability and low regulation, the value of SCR should be high, which requires large air gap. When the length of air gap is large, the mmf requirement will be high and so the field system will be large. Hence the machine will be costlier.

What are the advantages of large air gap in synchronous machines?

The advantages of large air gap are:

- Reduction in armature reaction
- Small value of regulation
- Higher value of stability
- Better cooling
- Lower tooth pulsation losses
- Smaller unbalanced magnetic pull

Write the expression for the length of air gap in salient pole synchronous machine.

$$\text{Length of air-gap, } l_g = \frac{AT_f}{B_g K_g * 10^6} \quad (\text{or}) \quad \frac{AT_a \text{ SCR } K_f}{B_{av} K_g * 10^6}$$

50. Why alternators are rated in KVA?

The KVA rating of ac machine depends on the power factor of the load. The power factor in turn depends on the operating conditions. The operating conditions differ from place to place. Therefore the KVA rating is specified for all ac machines.

SOLVED PROBLEMS ON DC MACHINE MAGNETIC CIRCUIT

Example.1

Calculate the ampere-turns for the air gap of a dc machine given the following data.

Gross core length = 40cm, air gap length = 0.5cm, number of ducts = 5, width of duct = 1.0cm, slot pitch = 6.5cm, slot opening = 0.5cm, average value of flux density in the air gap = 0.63T. Field form factor = 0.7, Carter's coefficient = 0.72 for opening/gap-length = 2.0 and Carter's coefficient = 0.82 for opening/gap-length = 1.0.

Note: If the Carter's coefficient given is greater than 1.0, then it may be K_{gs} , K_{gv} or K_g . If the Carter's coefficient given is less than 1.0, then it may be δ_s or $(1 - \delta_s)$, δ_v or $(1 - \delta_v)$. Therefore K_{gs} and K_{gv} are to be found out to find out K_g . When the ratio b_{os}/l_g or b_v/l_g is less like 1, 2 or 3 and the Carter's coefficient given is close to 1.0, then it may be δ_s or δ_v . If it is close to zero, then it may be $(1 - \delta_s)$, or $(1 - \delta_v)$.

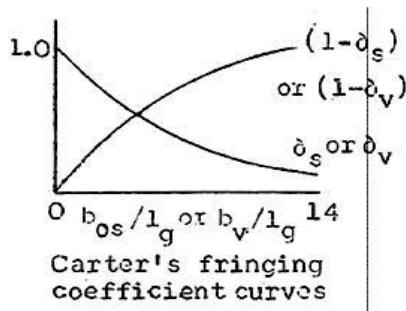

$$AT_g = 800000 l_g K_g B_g$$

$$K_g = \text{Carter's gap expansion coefficient} = K_{gs} \times K_{gv}$$

$$K_{gs} = \text{Carter's gap expansion coefficient for the slots} = \frac{\lambda_s}{\lambda_s - b_{os}(1 - \delta_s)}$$

$$\text{At } \frac{b_{os}}{l_g} = \frac{0.5}{0.5} = 1.0, \delta_s = 0.82$$

$$K_{gs} = \frac{6.5}{6.5 - 0.5(1 - 0.82)} = 1.014$$

$$K_{gv} = \text{Carter's gap expansion coefficient for the ducts} = \frac{L}{L - n_v b_v (1 - \delta_v)}$$

$$\text{At } \frac{b_v}{l_g} = \frac{1.0}{0.5} = 2.0, \delta_v = 0.72$$

$$K_{gv} = \frac{40}{40 - 5 \times 1(1 - 0.72)} = 1.04$$

$$K_g = 1.014 \times 1.04 = 1.054$$

$$\text{Maximum value of flux density in the air gap } B_g = \frac{B_{av}}{K_f} = \frac{0.63}{0.7} = 0.9T$$

$$AT_g = 800000 \times 0.5 \times 10^{-2} \times 1.054 \times 0.9 = 3794.4$$

Example.2

Calculate the ampere turns required for the air gap of a DC machine given the following data. Gross core length = 40cm, air gap length = 0.5 cm, number of ducts = 5, width of each duct = 1.0cm, slot pitch = 6.5cm, average value of flux density in the air gap = 0.63T. Field form factor = 0.7, Carter's coefficient = 0.82 for opening/gap length = 1.0 and Carter's coefficient = 0.82 for opening/gap length = 1.0, and Carter's coefficient = 0.72 for opening/gap length = 2.0.

$$AT_g = 800000 l_g K_g B_g$$

$$K_g = \text{Carter's gap expansion coefficient} = K_{gs} \times K_{gv}$$

$$K_{gs} = \text{Carter's gap expansion coefficient for the slots} = \frac{\lambda_s}{\lambda_s - b_{os}(1 - \delta_s)}$$

Since $\frac{b_v}{l_g} = 1.0/0.5 = 2.0$, corresponds to ducts, opening/gap-length = 1.0, must correspond to slots. Therefore, opening of the slot $b_{os} = l_g \times 1.0 = 0.5 \times 1.0 = 0.5\text{cm}$.

$$\text{At } \frac{b_{os}}{l_g} = \frac{0.5}{0.5} = 1.0, \delta_s = 0.82$$

$$K_{gs} = \frac{6.5}{6.5 - 0.5(1 - 0.82)} = 1.014$$

$$K_{gv} = \text{Carter's gap expansion coefficient for the ducts} = \frac{L}{L - n_v b_v(1 - \delta_v)}$$

$$\text{At } \frac{b_v}{l_g} = \frac{1.0}{0.5} = 2.0, \delta_v = 0.72$$

$$K_{gv} = \frac{40}{40 - 5 \times 1(1 - 0.72)} = 1.04$$

$$K_g = 1.014 \times 1.04 = 1.054$$

$$\text{Maximum value of flux density in the air gap } B_g = \frac{B_{av}}{K_f} = \frac{0.63}{0.7} = 0.9T$$

$$AT_g = 800000 \times 0.5 \times 10^{-2} \times 1.054 \times 0.9 = 3794.4$$

Problems on transformer main dimensions and windings

1. Determine the main dimensions of the core and window for a 500 kVA, 6600/400V, 50Hz, Single phase core type, oil immersed, self cooled transformer. Assume: Flux density = 1.2 T, Current density = 2.75 A/mm², Window space factor = 0.32, Volt / turn = 16.8, type of core: Cruciform, height of the window = 3 times window width. Also calculate the number of turns and cross-sectional area of the conductors used for the primary and secondary windings.

Since volt / turn $E_t = 4.44 \phi_m f$,

$$\text{Main or Mutual flux } \phi_m = \frac{E_t}{4.44 f} = \frac{16.8}{4.44 \times 50} = 0.076 \text{ Wb}$$

$$\text{Net iron area of the leg or limb } A_i = \frac{\phi_m}{B_m} = \frac{0.076}{1.2} = 0.0633 \text{ m}^2$$

Since for a cruciform core $A_i = 0.56d^2$,

$$\text{diameter of the circumscribing circle } d = \sqrt{\frac{A_i}{0.56}} = \sqrt{\frac{0.0633}{0.56}} = 0.34 \text{ m}$$

width of the largest stamping $a = 0.85d = 0.85 \times 0.34 = 0.29 \text{ m}$

width of the transformer = $a = 0.29 \text{ m}$

width of the smallest stamping $b = 0.53d = 0.53 \times 0.34 = 0.18 \text{ m}$

Height of the yoke $H_y = (1.0 \text{ to } 1.5) a = a \text{ (say)} = 0.29 \text{ m}$

$$\text{kVA} = 2.22 f \delta A_i B_m A_w K_w \times 10^{-3}$$

$$500 = 2.22 \times 50 \times 2.75 \times 10^6 \times 0.0633 \times 1.2 \times A_w \times 0.32 \times 10^{-3}$$

$$\text{Area of the window } A_w = 0.067 \text{ m}^2$$

$$\text{Since } H_w = 3 W_w, A_w = H_w W_w = 3W_w^2 = 0.067$$

$$\text{Therefore, width of the window } W_w = \sqrt{\frac{0.067}{3}} = 0.15 \text{ m}$$

$$\text{and height of the window } H_w = 3 \times 0.15 = 0.45 \text{ m}$$

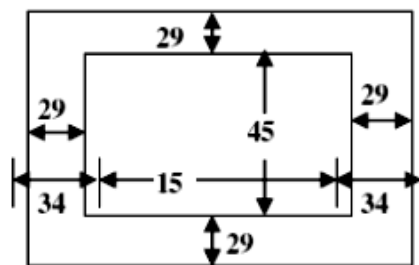

Details of the core

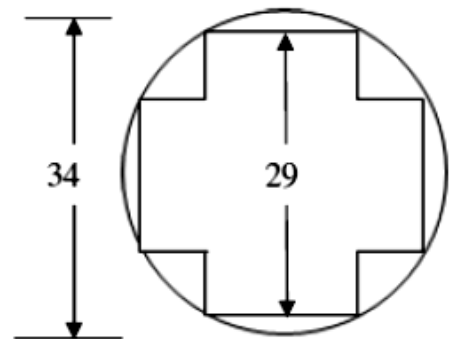

Leg and yoke section (with the assumption Yoke is also of cruciform type)

All dimensions are in cm

Overall length of the transformer = $W_w + d + a = 0.15 + 0.34 + 0.29 = 0.78$ m

Overall height of the transformer = $H_w + 2H_y$ or $2a = 0.45 + 2 \times 0.29 = 1.03$ m

Width or depth of the transformer = $a = 0.29$ m

Number of primary turns $T_1 = \frac{V_1}{E_t} = \frac{6600}{16.8} \approx 393$

Number of secondary turns $T_2 = \frac{V_2}{E_t} = \frac{400}{16.8} \approx 24$

Primary current $I_1 = \frac{\text{kVA} \times 10^3}{V_1} = \frac{500 \times 10^3}{6600} = 75.75$ A

Cross-sectional area of the primary winding conductor $a_1 = \frac{I_1}{\delta} = \frac{75.75}{2.75} = 27.55$ mm²

Secondary current $I_2 = \frac{\text{kVA} \times 10^3}{V_2} = \frac{500 \times 10^3}{400} = 1250$ A

Cross-sectional area of the secondary winding conductor $a_2 = \frac{I_2}{\delta} = \frac{1250}{2.75} = 454.5$ mm²

2. Determine the main dimensions of the 3 limb core (i.e., 3 phase, 3 leg core type transformer), the number of turns and cross-sectional area of the conductors of a 350 kVA, 11000/ 3300 V, star / delta, 3 phase, 50 Hz transformer. Assume: Volt / turn = 11, maximum flux density = 1.25 T. Net cross-section of core = $0.6 d^2$, window space factor = 0.27, window proportion = 3 : 1, current density = 250 A/cm², ON cooled (means oil immersed, self cooled or natural cooled) transformer having $\pm 2.5\%$ and $\pm 5\%$ tapping on high voltage winding

$$\phi_m = \frac{E_t}{4.44 f} = \frac{11}{4.44 \times 50} = 0.05 \text{ Wb}$$

$$A_i = \frac{\phi_m}{B_m} = \frac{0.05}{1.25} = 0.04 \text{ m}^2$$

$$\text{Since } A_i = 0.6 d^2, d = \sqrt{\frac{A_i}{0.6}} = \sqrt{\frac{0.04}{0.6}} = 0.26 \text{ m}$$

Since $A_i = 0.6 d^2$ corresponds to 3 stepped core, $a = 0.9d = 0.9 \times 0.26 = 0.234$ m

Width or depth of the transformer = $a = 0.234$ m

$H_y = (1.0 \text{ to } 1.5) a = 1.0 a$ (say) = 0.234 m

$$\text{kVA} = 3.33 f \delta A_i B_m A_w K_w \times 10^{-3}$$

$$350 = 3.33 \times 50 \times 250 \times 10^4 \times 0.04 \times 1.25 \times A_w \times 0.27 \times 10^{-3}$$

$$A_w = 0.062 \text{ m}^2$$

Since window proportion $\frac{H_w}{W_w}$ is 3 : 1, $H_w = 3W_w$ and $A_w = 3W_w^2 = 0.062$

$$\text{Therefore } W_w = \sqrt{\frac{0.062}{3}} = 0.143 \text{ m and } H_w = 3 \times 0.143 = 0.43 \text{ m}$$

$$H_y = (1.0 \text{ to } 1.5) a = 1.0 a \text{ (say)} = 0.234 \text{ m}$$

$$\text{kVA} = 3.33 f \delta A_i B_m A_w K_w \times 10^{-3}$$

$$350 = 3.33 \times 50 \times 250 \times 10^4 \times 0.04 \times 1.25 \times A_w \times 0.27 \times 10^{-3}$$

$$A_w = 0.062 \text{ m}^2$$

Since window proportion $\frac{H_w}{W_w}$ is 3 : 1, $H_w = 3W_w$ and $A_w = 3W_w^2 = 0.062$

$$\text{Therefore } W_w = \sqrt{\frac{0.062}{3}} = 0.143 \text{ m and } H_w = 3 \times 0.143 = 0.43 \text{ m}$$

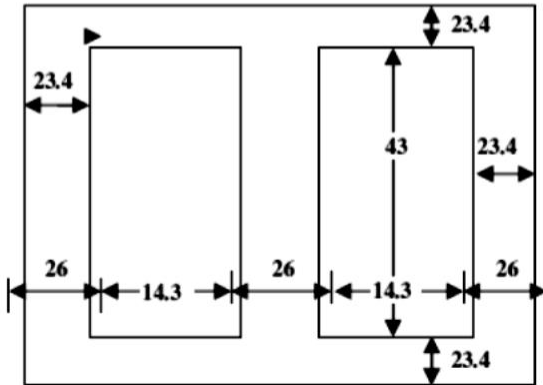

Details of the core

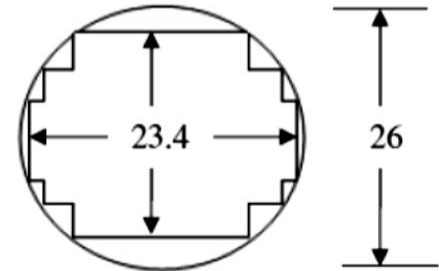

Leg and Yoke section
All dimensions are in cm

$$\text{Overall length of the transformer} = 2W_w + 2d + a = 2 \times 14.3 \times 2 \times 26 + 23.4 = 104 \text{ cm}$$

$$\text{Overall height of the transformer} = H_w + 2H_y \text{ or } 2a = 43 + 2 \times 23.4 = 89.8 \text{ cm}$$

$$\text{Width or depth of the transformer} = a = 23.4 \text{ cm}$$

[with + 2.5% tapping, the secondary voltage will be 1.025 times the rated secondary voltage. To achieve this with fixed number of secondary turns T_2 , the voltage / turn must be increased or the number of primary turns connected across the supply must be reduced.]

$$\text{Number of secondary turns } T_2 = \frac{V_2}{E_t} = \frac{3300}{11} = 300$$

$$\text{Number of primary turns for rated voltage } T_1 = \frac{V_1}{E_t} = \frac{11000 / \sqrt{3}}{11} \approx 577$$

$$\text{Number of primary turns for + 2.5% tapping} = T_2 \times E_1 \text{ required } E_2 \text{ with tapping}$$

$$= 300 \times \frac{11000 / \sqrt{3}}{1.025 \times 3300} \approx 563$$

$$\text{for - 2.5% tapping} = 300 \times \frac{11000 / \sqrt{3}}{0.975 \times 3300} \approx 592$$

$$\text{for } +5\% \text{ tapping} = 300 \times \frac{11000/\sqrt{3}}{1.05 \times 3300} \approx 550$$

$$\text{for } -5\% \text{ tapping} = 300 \times \frac{11000/\sqrt{3}}{0.95 \times 3300} \approx 608$$

Obviously primary winding will have tappings at 608th turn, 592nd turn, 577th turn, 563rd turn and 550th turn.

$$\text{primary current / ph } I_1 = \frac{\text{kVA} \times 10^3}{3V_{1\text{ph}}} = \frac{350 \times 10^3}{3 \times 11000/\sqrt{3}} = 18.4 \text{ A}$$

$$\text{Cross-sectional area of the primary winding conductor } a_1 = I_1 / \delta = 18.4 / 250 = 0.074 \text{ cm}^2$$

$$\text{Secondary current / ph } I_2 = \frac{\text{kVA} \times 10^3}{3V_{2\text{ph}}} = \frac{350 \times 10^3}{3 \times 3300} = 35.35 \text{ A}$$

$$\text{Cross-sectional area of the secondary winding conductor } a_2 = I_2 / \delta = 35.35 / 250 = 0.14 \text{ cm}^2$$

Design of cooling tank and tubes

1. Design a suitable cooling tank with cooling tubes for a 500 kVA, 6600/440V, 50Hz, 3 phase transformer with the following data. Dimensions of the transformer are 100 cm height, 96 cm length and 47 cm breadth. Total losses = 7 kw. Allowable temperature rise for the tank walls is 35°C. Tubes of 5 cm diameter are to be used. Determine the number of tubes required and their possible arrangement.

Tank height H_t = transformer height + clearance of 30 to 60 cm = 100 + 50 = 150 cm

Tank length L_t = transformer length + clearance of 10 to 20 cm = 96 + 14 = 110 cm

width or breadth of the tank W_t = transformer width or breadth + clearance of 10 to 20 cm

$$= \text{clearance of } 47 + 13 = 60 \text{ cm}$$

$$\text{Losses} = 12.5 S_t \theta + 8.78 A_t \theta$$

Dissipating surface of the tank (neglecting the top and bottom surfaces)

$$S_t = 2H_t (L_t + W_t) = 2 \times 1.5 (1.1 + 0.6) = 5.1 \text{ m}^2$$

$$7000 = 12.5 \times 5.1 \times 35 + 8.78 A_t \times 35$$

$$\text{Area of all the tubes } A_t = 15.6 \text{ m}^2$$

Dissipating area of each tube $a_t = \pi \times \text{diameter of the tube} \times \text{average height or length of the tube}$

$$= \pi \times 0.05 \times 0.9 \times 1.5 = 0.212 \text{ m}^2$$

$$\text{Number of tubes } n_t = \frac{A_t}{a_t} = \frac{15.6}{0.212} = 73.6 \text{ \& is not possible. Let it be } 74.$$

If the tubes are placed at 7.5 cm apart from centre to centre, then the number of tubes that can be provided along 110 cm and 60 cm sides are $\frac{110}{7.5} \approx 15$ and $\frac{60}{7.5} \approx 8$ respectively.

Therefore number of tubes that can be provided in one row all-round = $2(15 + 8) = 46$. Since there are 74 tubes, tubes are to be arranged in 2nd row also. If 46 more tubes are provided in second row, then total number of tubes provided will be 92 and is much more than 74. With 13 & 6 tubes along 100 cm & 60 cm sides as shown, total number of tubes provided will be $2(13 + 6) = 38$ though 74 are only required.

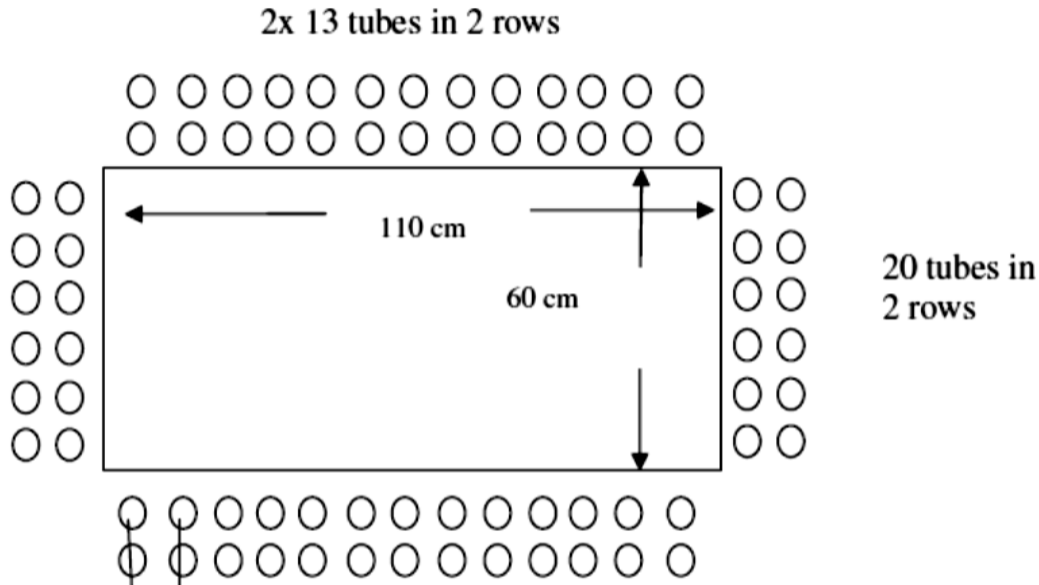

2. A 3 phase 15 MVA, 33/6.6 kV, 50 Hz, star/delta core type oil immersed natural cooled transformer gave the following results during the design calculations. Length of core + 2 times height of yoke = 250 cm, centre to centre distance of cores = 80 cm, outside diameter of the HV winding = 78.5 cm, iron losses = 26 kw, copper loss in LV and HV windings = 41.5 kW & 57.5 kW respectively.

Calculate the main dimensions of the tank, temperature rise of the transformer without cooling tubes, and number of tubes for a temperature rise not to exceed 50⁰C.

Comment upon whether tubes can be used in a practical case for such a transformer. If not suggest the change.

$$H_t = 250 + \text{clearance of (30 to 60) cm} = 250 + 50 = 300 \text{ cm}$$

$$L_t = 2 \times 80 + 78.5 + \text{clearance of (10 to 20) cm} = 238.5 + 11.5 = 250 \text{ cm}$$

$$W_t = 78.5 + \text{clearance of (10 to 20) cm} = 78.5 + 11.5 = 90 \text{ cm}$$

$$\text{Without tubes, losses} = 12.5 S_t \theta$$

$$S_t = 2 H_t (L_t + W_t) = 2 \times 3 (2.5 + 0.9) = 20.4 \text{ m}^2$$

$$\theta = \frac{(26 + 41.5 + 57.5) 10^3}{12.5 \times 20.4} = 490^\circ \text{C}$$

with cooling tubes, losses = $12.5 S_t \theta + 8.78 A_t \theta$

$$A_t = \frac{(26 + 41.5 + 57.5) 10^3 - 12.5 \times 20.4 \times 50}{8.78 \times 50} = 255.6 \text{ m}^2$$

With 5 cm diameter tubes $a_t = \pi \times 0.05 \times 0.9 \times 3 = 0.424 \text{ m}^2$

$$n_t = \frac{255.6}{0.424} \approx 603$$

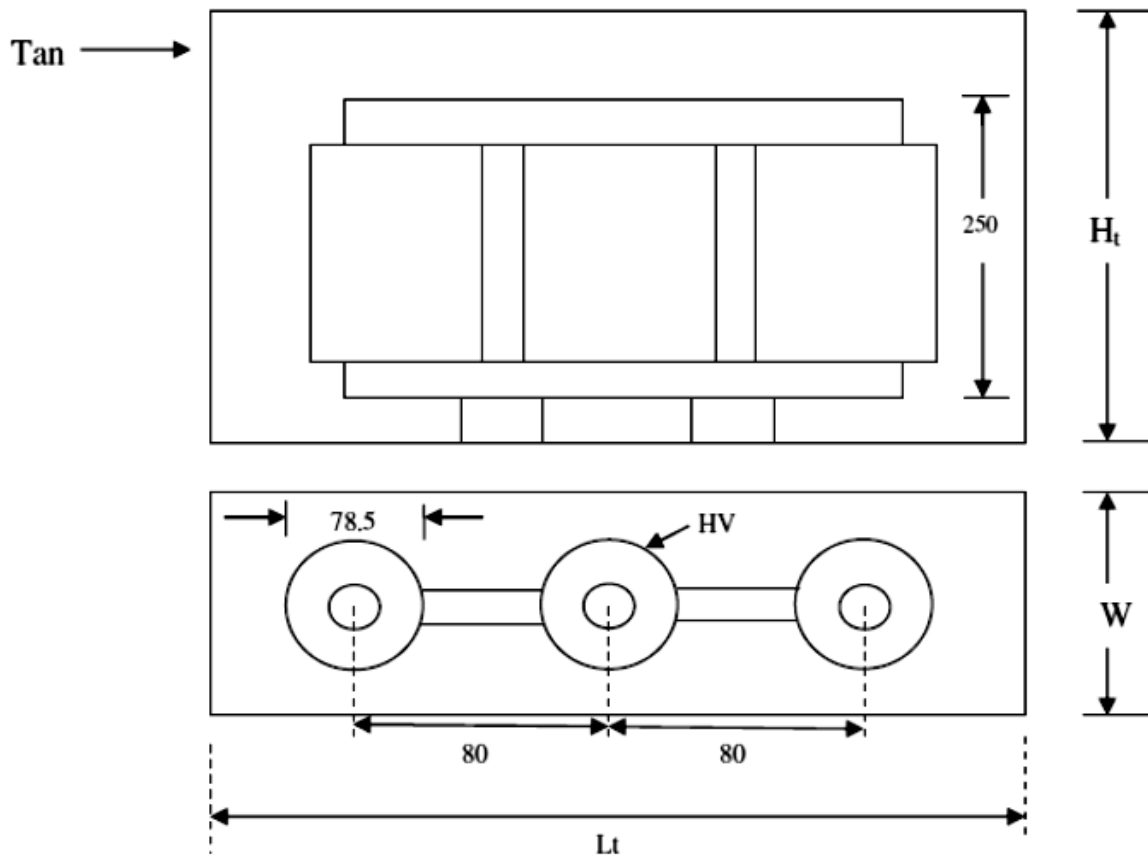

All dimensions are in cms.

If tubes are provided at 7.5 cm apart from centre to centre, then the number of tubes that can be provided along 250 cm and 90 cm sides are $250 / 7.5 \approx 33$ and $90 / 7.5 \approx 12$ respectively.

Number of tubes in one row = $2 (33 + 12) = 90$.

Therefore number of rows required = $603 / 90 \approx 7$.

As the number tubes and rows increases, the dissipation will not proportionately increase. Also it is difficult to accommodate large number of tubes on the sides of the tank. In such cases external radiator tanks are preferable & economical.

MODEL QUESTION PAPER – I
ELECTRICAL AND ELECTRONICS ENGINEERING
EE 2355 – DESIGN OF ELECTRICAL APPARATUS

Time: 3 Hours

[Max. Marks: 100]

ANSWER ALL QUESTIONS

PART-A(10X2=20)

1. What are the major considerations to evolve a good design of electrical machine?
2. Name the types of magnetic materials based on hysteresis loops.
3. What is meant by magnetic circuit calculations?
4. Define field form factor.
5. Why circular coils are preferred in transformers?
6. Draw the cruciform section of the transformer and give the optimum designs in terms of Circumscribing circle diameter d .

Write the expression for output equation and co-efficient of induction motor.

How the induction motor can be designed for best power factor.

9. What is the limiting factor for the diameter of synchronous machine?
10. What is SCR?

PART-B(5X16=80)

i) Derive an expression for the thermal resistivity of winding and prove that the square of the length of the copper per metre of winding thickness is equal to space factor. **(10)**

ii) What are the limitations in the design of electrical apparatus? Explain them. **(6)**

12. a) i) Derive the output equation of a D.C. machine **(6).**

Determine the diameter and length of armature core for a 55 KW, 110 V, 1000 rpm, 4-pole shunt generator, assuming specific electric and magnetic loadings of 26000 amp.cond./m and 0.5 Wb/m^2 respectively. The pole arc should be about 70% of pole pitch and the length of core about 1.1 times the pole arc. Allow 10 ampere for the field current and assume a voltage drop of 4 Volts for the armature circuit. Specify the windings used and also determine suitable values for the number of armature conductors and number of slots. **(10)**

[OR]

12. b) i) Calculate the mmf required for the air-gap of a D.C. machine with an axial length of

20 cm (no ducts) and a pole arc of 18 cm, the slot pitch = 27mm, slot opening = 12mm, air-gap = 6 mm and the useful flux per pole = 2.34 m Wb, Take Carter's co-efficient for slots as 0.3. (6)

Design a suitable commutator for a 350 KW, 600 rpm, 440 V, 6-pole D.C.generator having an armature diameter of 0.75 m. The number of coils is 288, Assume suitable values wherever necessary. (10)

13. a) i) Derive the output equation of three-phase transformer. (6)

Estimate the main dimensions including winding conductor area of a 3-phase, delta to star core type transformer rated at 300KVA, 6600/440 V, 50 Hz. A suitable core with three steps having a circumscribing circle of 0.25 m diameter and a leg spacing of 0.4 m is available. $\delta = 2.5$ A/mm², E.M.F. per turn = 8.5 V, $K_w = 0.28$, $S_f = 0.9$ (space factor). (10)

[OR]

13. b) i) How to design the windings of a transformer? (6)

A 250 KVA, 6600/400 V, 3-phase core type transformer has a total loss of 4800W on full load. The transformer tank is 1.25mm in height and 1 X 0.5 in plan. Design a suitable scheme for cooling tubes if the average temperature rise is to be 35 deg. The diameter of the tube is 50 mm and is spaced 75mm from each other. The average height of the tube is 1.05m. (10)

a) Give a detailed procedure for the design of rotor bars and end rings of a squirrel cage induction motor. (16)

[OR]

Estimate the main dimensions, air-gap length, stator slots, stator turns/phase and cross-sectional area of the stator and rotor conductors for a 3-phase, 15 HP, 400V, 6-pole, 50 Hz, 975 rpm, induction motor. The motor is suitable for star delta starting. $B_{av} = 0.45$ Wb/m², $L \tau = 0.85$, p.f.= 0.85, efficiency = 0.9, ac = 20,000 amp.cond./metre. (16)

15. a) i) Give the comparison between single and double layer winding. (6)

Determine the main dimensions for a 1000 KVA, 50 Hz, 3-phase, 375 rpm, alternator. The average air-gap flux density is 0.55 Wb/m² and the ampere conductors per metre are 28000. Use rectangular poles and assume a suitable value for ratio of core length to pole pitch in order that bolted on pole construction is used for which the maximum permissible peripheral speed is 50 m/s. the run away speed is 1.8 times the synchronous speed. (10)

[OR]

i) Explain the choice of specific magnetic and electric loadings of synchronous machines. (6)

With a neat sketch, indicate the location of the damper windings in a synchronous machine and mention its uses. (10)

MODEL QUESTION PAPER – II
SEVENTH SEMESTER
ELECTRICAL AND ELECTRONICS ENGINEERING
EE 2355 – DESIGN OF ELECTRICAL APPARATUS

Time: 3 Hours

[Max. Marks: 100]

ANSWER ALL QUESTIONS

PART-A(10X2=20)

State the electrical engineering materials used in the construction of A.C. generators and A.C.motors.

Define window space factor and state its importance.

State two factors which should be considered while selecting the number of poles in a D.C.generator.

State the relative merits of lap and wave windings of armature of a D.C. generator.

Define voltage regulation of a transformer and state its importance.

State the factors on which the thermal time constant of a transformer depends.

How is leakage reactance different from magnetizing reactance in the case of three phase induction motor?

State two rules for selecting the number of rotor slots in the case of three phase squirrel cage induction motor.

How does damper winding improve the performance of a synchronous machine?

State the factors that must be considered in choosing air-gap length in case of a synchronous generator.

PART-B(5X16=80)

- i)** Derive output equation of a single phase transformer and point out salient features of this equation. **(4)**
 Explain different methods of cooling a transformer with relevant sketches. State relative merits and limitations of these methods. **(4)**
- iii)** Compute the main dimensions of the core of a 5 KVA, 11000/400 volts, 50Hz single phase core type transformer. Window space factor = 0.2; The height of the window is 3 times its width; Current density = 1.4 A/mm^2 ; $B_{\max} = 1.0 \text{ Tesla}$; Stacking factor = 0.9; Net conductor area in the window = 0.6 times the net cross – sectional area of iron in the core. Assume square cross-section for the core. **(8)**
- a) i)** state different kinds of insulating materials used in the manufacture of generators and motors of A.C. and D.C. type and transformer. **(8)**
 ii) A field coil has a cross-section of 100mm X 50mm. It has length of mean turn

equal to 1 m. Estimate the hot spot temperature above that of the outer surface of the coil is 120 Watts. Space factor = 0.56; Thermal resistivity of insulating material = 8 ohms m. (8)

[OR]

b) i) State different kinds of magnetic materials used in the construction of rotating machines and transformers. Point out their salient features. (8)

What are the different conductor materials used in the construction of transformers and DC and AC machines? Point out salient properties of these materials. (8)

a) i) Derive output equation of a D.C. generator and point out salient features of this equation. (8)

State and justify the criteria for selection of a suitable diameter of armature of a D.C. generator. (8)

[OR]

13. b) A 5 KW, 250V, 4-pole, 1500 rpm dc shunt generator is designed to have $B_{av} = 0.42$ Wb/m²,

Ampere conductors per metre = 15000

Full load efficiency = 87%

Ratio of pole arc to pole pitch = 0.66

Compute the main dimensions of the armature. (16)

a) i) Derive output equation of a three phase induction motor and point out salient features of this equation. (8)

State and justify the criteria for selection of average flux density in the air-gap of three phase induction motor. (8)

[OR]

b) Compute main dimensions D and L of a 3.7 KW, 400V, 3-phase, 4-pole, 50 Hz Squirrel cage induction motor.

$B_{av} = 0.45$ Wb/m²

Electrical loading = 23000 Amp-conductors/metre

Efficiency = 85%

Power factor = 0.84

Winding factor = 0.955

Stacking factor = 0.9. (16)

a) Compute main dimensions D and L for a three phase alternator which is rated 1000 KVA, 50 Hz, 375 rpm.

$B_{av} = 0.55$ Wb/m²

Amp-conductors/metre = 28,000

The ratio of core length to pole pitch = 2

Winding factor = 0.955. (16)

[OR]

b) A 500 KVA, 3.3KV, 50 Hz, 600 rpm three phase salient pole alternator has 180 turns per phase. Estimate the length of air-gap if the average flux density is 0.54 Tesla.

The ratio of pole arc to pole pitch = 0.65

The short circuit ratio = 1.2

The gap contraction factor = 1.15

Winding factor = 0.955

The MMF required for air-gap is 80 percent of no load field MMF. (16)

MODEL QUESTION PAPER – III
SEVENTH SEMESTER
ELECTRICAL AND ELECTRONICS ENGINEERING
EE 2355 – DESIGN OF ELECTRICAL APPARATUS

Time: 3 Hours**[Max. Marks: 100]****ANSWER ALL QUESTIONS****PART–A(10X2=20)**

State the properties which determine the suitability of a material for insulating materials.

Define space factor of a coil.

Write an expression for the mmf to be produced by each pole.

What is apparent flux density?

State the various methods of cooling of large power transformers.

State the various types of limb sections of core type transformer.

State the various types of leakage fluxes.

Define dispersion co-efficient.

What is meant by Runaway speed?

State the advantages of double layer winding.

PART–B(5X16=80)

11. i) Explain how to select the number of poles for a D.C. machine. **(6)**

The commutator of a 10 pole, 1000 KW, 500 Volt, 300 rpm D.C. generator has 450 segments and an external diameter of 1 meter. Determine a suitable axial length for the commutator, giving details of brushes having regard to commutation and temperature rise. Assume current density as 6 amps/cm^2 , voltage drop due to brush contact as 2.2 volt, brush pressure as 1250 Kg/m^2 and co-efficient of friction as 0.25

(10)

12. a) i) Discuss the requirements of high conductivity materials. **(8)**

Write notes on temperature gradient in conductors placed in slots, with help of equations. **(8)**

[OR]

12. b) i) Explain heat flow in two dimensions. **(8)**

ii) Write notes on classification of insulating materials. **(8)**

13. a) i) Derive the voltage per turn equation for a single phase transformer. **(8)**

A 250 KVA transformer gives a temperature rise of 20 deg. Celsius after 1 hour of full load and 33.5 deg. Celsius after 2 hours. Find out the percentage overload to which the transformer can be subjected safely for 1 hour, if it has maximum efficiency on full load. (8)

[OR]

13. b) i) Explain the design procedure of cooling tubes for a transformer. (8)

Estimate the no load current of a 400 volt, 50 Hz, single phase transformer with the following particulars: Length of mean magnetic path = 200 cm, gross cross-section 100 cm^2 , joints are equivalent to 0.1mm air-gap, maximum flux density = 0.7 Wb/m^2 , magnetizing force corresponding to 0.7 Wb/m^2 is 0.5 watt/Kg. Assume a stacking factor of 0.9. (8)

14. a) i) Discuss the rules for the selection of rotor slots for a cage induction rotor. (8)

Determine the main dimensions for a 15 HP, 400 volt, 3-phase, 4-pole, 1425 rpm Induction motor. Adopt a specific magnetic loading of 0.45 Wb/m^2 and a specific electric loading of 230 ac/m. Assume that a full load efficiency of 85% and a full load power factor of 0.88, will be obtained. (8)

[OR]

b) i) Derive an expression to find the specific slot permeance of a fully opened rectangular slot. (8)

A 5 HP, 440 volt, 3 phase, 4 pole cage motor with 375 turns/phase in the stator has the following design data for its rotor. Slots = 30, rotor bar size = 8.5 mm X 6 mm; length of the bar = 12.5 cm; end ring size = 10 mm X 15 mm; inner diameter of the end ring = 11.5 cm. Calculate the rotor resistance when referred to the stator winding. Assume specific resistance as $2 \times 10^{-6} \text{ cm}$. (8)

a) i) Discuss the effects of short circuit ratio on the performance of a synchronous machine. (8)

A 2 pole, 50 Hz turbo alternator has a core length of 1.5 m. the mean flux density over the pole pitch is 0.5 Wb/m^2 , the stator ampere conductors per cm are 260 and peripheral speed 100 metre/second. The average span of the stator coils is one pole pitch. Determine the output which can be obtained from the machine. (8)

[OR]

b) i) What are the various types of synchronous machines based on rotor construction? Bring out the constructional differences between them. (8)

A 1250 KVA, 3 phase, 6000 volt alternator has the following data: air-gap diameter = 160 cm, core length = 45 cm, number of poles = 20, armature ampere Conductors per metre = 2800, pole pitch = 0.68, stator slot pitch = 2.8 cm and current density in the damper bars 3A/mm^2 . Design a suitable damper winding for the machine. (8)

MODEL QUESTION PAPER – IV
SEVENTH SEMESTER
ELECTRICAL AND ELECTRONICS ENGINEERING
EE 2355 – DESIGN OF ELECTRICAL APPARATUS

Time: 3 Hours

[Max. Marks: 100]

ANSWER ALL QUESTIONS

PART-A(10X2=20)

Define rating of a motor.

Why total loadings are not used to determine the output of a rotating machine?

Calculate the mmf per meter for a flux density of 1.7 Wb/m^2 and a permeability of $23.5 \times 10^{-6} \text{ H/m}$.

State the relation between the armature diameter and commutator diameter for various ratings of dc machines.

The voltage per turn of a 500 KVA, 11 KV/415 V, delta/star, 3-phase transformer is 8.7V. Calculate the number of turns per phase of L and V and II V windings.

What is conservator?

Write the formula for air-gap in case of three phase induction motor in terms of length and diameter.

Define dispersion co-efficient.

Sketch the shape of rotor for a turbo alternator.

Why the field structure is a rotating member in 3 phase synchronous machine?

PART-B(5X16=80)

11. i) Explain the rotor design procedure of a turbo alternator. (8)

Determine the area of rotor conductors of a 30 KVA, 11 KV, 3000 rpm, 50 Hz, 3-phase air-cooled turbo alternator. The load power factor is 0.8 lagging. Assume peripheral speed = 130 m/s and $S_f = 2.5 \text{ A/mm}^2$. Make other suitable assumptions for a conventionally cooled generator. (8)

12. a) i) Write a note on classification of insulating materials. (6)

Derive an expression for thermal resistivity of winding and prove that the square of

the length of the copper per metre of winding thickness is equal to space factor. (10)

[OR]

12. b) i) What are the limitations in the design of electrical apparatus? (6)

Write a note on temperature gradients in conductors placed in slots with the help of equations. (10)

13. a) i) Derive the output equation of a D.C. machine. (6)

A 4 pole, 25 HP, 500 V, 600 rpm series motor has an efficiency of 82%. The pole faces are square and the ratio of pole arc to pole pitch is 0.67. Take B_{av} 0.55 Wb/m^2 and $a_c = 17000 \text{ amp.cond./m}$. Obtain the main dimensions of the core and particulars of a suitable armature winding. (10)

[OR]

b) i) Determine the air-gap length of a D.C. machine from the following particulars: Gross length of core = 0.12 m

No. of ducts = 1 and is 10 mm

wide Slot pitch = 25 mm

Slot width = 10 mm

Carter's co-efficient for slots and ducts = 0.32

Gap density at pole centre = 0.7 Wb/m^2

Field mmf per pole = 390 deg. AT

Mmf required for iron parts of magnetic circuit = 800 AT. (6)

A 500 KW, 460 V, 8 pole, 375 rpm compound generator has an armature diameter of 1.1 m and a core length of 0.33 m. Design a symmetrical armature winding, giving the details of equalizers. The ampere conductors per meter are 34000. The internal voltage drop is 4 percent of terminal voltage and the field current is 1 percent of output current. The ratio of pole arc to pole pitch is 0.7. The voltage between adjacent segments at no load should not exceed 15 V and the slot loading should not exceed 15000 A. the diameter of commutator is 0.65 of armature diameter and the minimum allowable pitch of segments is 4 mm. Make other suitable assumptions. (10)

14. a) i) Derive the output equation of three phase transformer. (6)

A 250 KVA, 6600/400 V, 3-phase core type transformer has a total loss of 4800W on full load. The transformer tank is 1.25m in height and 1 X 0.5 in plan. Design a suitable scheme for cooling tubes if the average temperature rise is to be 35 deg. The diameter of the tube is 50 mm and is spaced 75mm from each other. The average height of the tube is 1.05m. Specific heat dissipation due to radiation and convection is respectively 6 and $6.5 \text{ W/m}^2 - \text{deg. celcius}$. Assume that convection is improved by 35% due to provision of tubes. (10)

[OR]

b) i) How will you estimate no load current in single and three phase transformer? (6)

A 15,000 KVA, 53/6.6 KV, 3 phase star/delta, core type transformer has the following data:

Net iron area of each limb = 1.5×10^{-3}

m^2 Net area of yoke = $1.8 \times 10^{-3} m^2$

Mean length of flux path in each limb = 2.3

Mean length of flux path in each yoke = 1.6

Number of turns in H.V. winding = 450.

Calculate the no-load current. Use the following data: **(10)**

MMF A/m	130	210	420	560	1300
Iron loss W/Kg	0.6	1.3	1.9	2.4	2.9

15. a) i) Explain the chance of specific electric loading of synchronous machines. (6)

A 1250 KVA, 3-phase, 50 Hz, 3300V, 300 rpm synchronous generator with a concentric winding has the following design data:

Specific magnetic loading = 0.58 Wb/m^2

Specific electric loading = 33,000 A/m

Gap length = 5.5 mm

Field turns per pole =

60 SCR = 1.2

The effective gap area = 0.6 times the actual area.

Peripheral speed = 30 m/s

Find the stator core length, stator bore, turns per phase, mmf for air-gap, armature mmf per pole and field current for no load and rated voltage. **(10)**

[OR]

15. b) i) Compare squirrel cage induction motor with wound rotor motors. (6)

Determine the D and L of a 70 HP, 415 V, 3-phase, 50 Hz, star connected, 6 pole induction motor for which $a_c = 30000 \text{ amp.cond./m}$ and $B_{av} = 0.51 \text{ tesla}$. Take efficiency = 90% and power factor = 0.91. Assume $\tau = L$. estimate the number of stator conductors required for a winding in which the conductors are connected in 2 paralleled paths. Choose a suitable number of conductors per slots, so that the slot loading does not exceed 1750 amp.cond./m.

(10)
